

REV	ECN NO	CONTENT	DATE	ENGINEER
A0		INITIAL RELEASE	/	LP

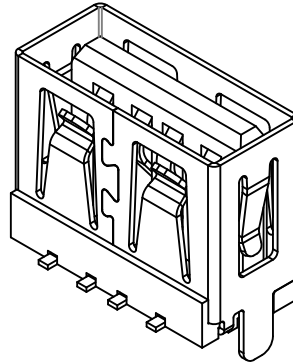

- 机械性能:**  
插入力:寿命测试前8~30N, 寿命测试后6~30N  
拔出力:寿命测试前10~25N, 寿命测试后8~30N  
耐插拔:500次/H, 3000 次  
工作温度:0℃~+50℃  
储存温度:-20℃~60℃
- 电气性能:**  
额定电流:3.0A Max.  
接触阻抗:寿命测试前30 mΩ Max. 寿命测试后50 mΩ Max  
耐高压:500V AC 1分钟 Min. 无击穿, 无电弧  
绝缘阻抗:1000 MΩ Min.
- 环境性能:**  
环 保: 产品符合ROHS要求  
盐雾测试: 温度35±2℃, 湿度: 95—98%; PH值: 6.5—7.2, 镀金区48H, 镀锡区24H, 镀镍区48H
- 焊接工艺:** 推荐使用回流焊, 本产品耐温260度, 6S
- 产品外观:** 表面洁净光亮, 无刮痕毛边镀层不良现象

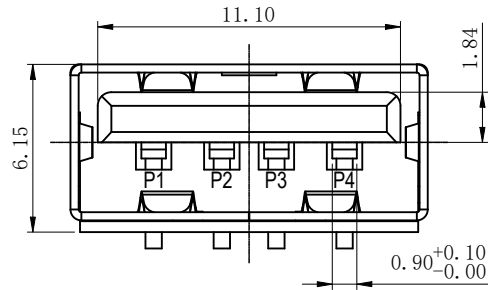
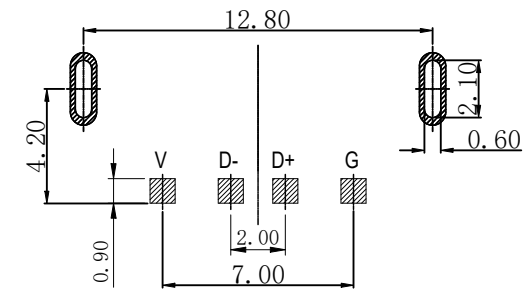
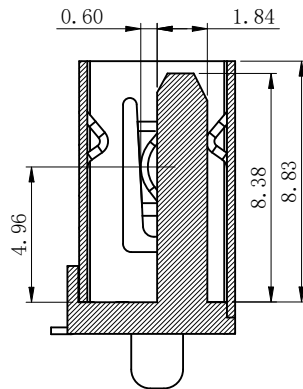
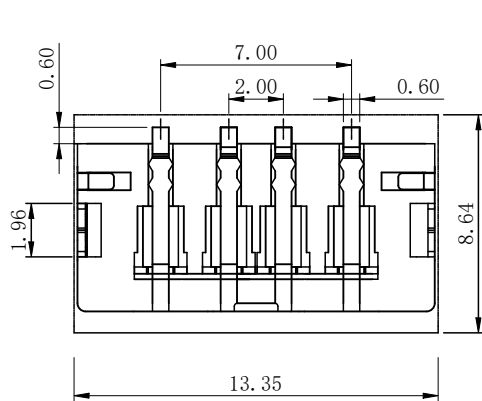
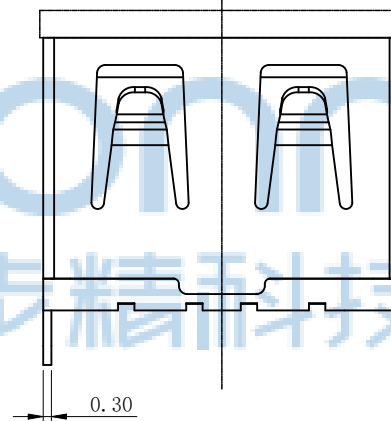
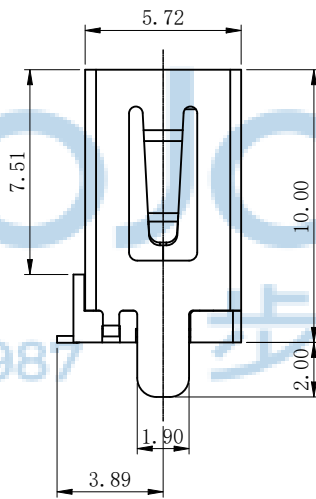
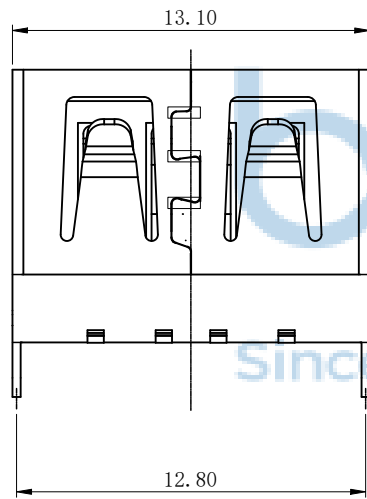

Recommend PCB layout

THIS DOCUMENT IS THE SOLE PROPERTY OF BBJconn Technology Co.,Ltd. Corporation AND SHOULD NOT BE USED IN WHOLE PRIOR WRITTEN PERMISSION.		<b>深圳市步步精科技有限公司</b>	
.X: ±0.38 .XX: ±0.25 .XXX: ±0.13		X*: ±3* X*: ±2* XX*: ±1*	
APPD	JM_Zheng	NAME: USB 2.0 AF 180度 H=10.00 两脚直插 端子SMT 平口 LCP黑胶 铜壳 端子镀金3u	
CHKD	LYX	PJ NO: UB.01.52-12-V003	
PDWG NO: 0383-1	DR	LP	SCALE:N/A REV:A0 UNIT:mm PAGE:1/2

1. 依圖所示放入載帶內, 每盤裝400PCS; 注意產品放置方向. (如下圖). 頭尾各留空10格.

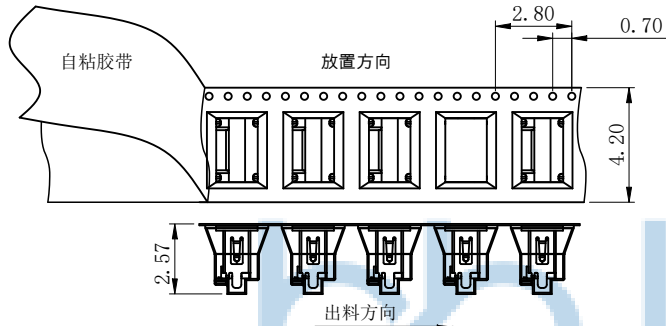

2. 卷裝好的後使用美紋紙粘好(如下圖).

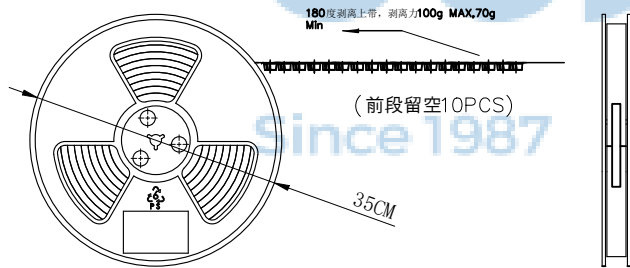

3. 把卷裝好的產品依序層疊裝入紙箱內然後放入護角. 每箱裝12盤 (4800PCS)

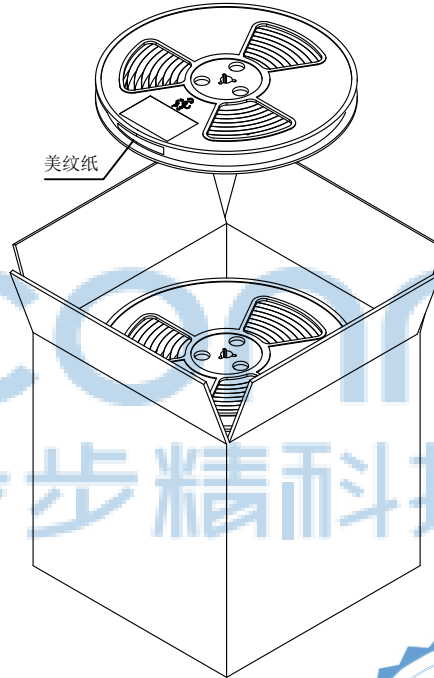

4. 外箱規格及外箱標籤貼附要求. (客戶指定要求之標籤及規格參照“客戶包裝規範”)

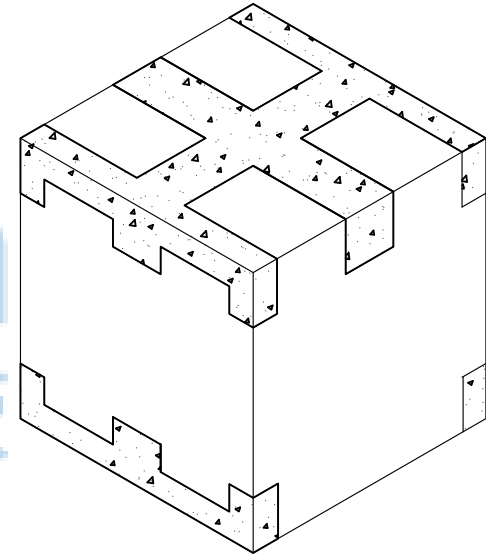

36\*36\*35CM



包材清單:				包裝數量:	
品名規格:	單重(g)	數量	成品單重	G/PCS	
01142#PVC載帶					
06#載帶盤		12 盤		400PCS/盤	
載帶保護膠圈					
47#紙箱		1 PCS		4800PCS/箱	

THIS DOCUMENT IS THE  
SOLE PROPERTY OF  
BBJconn Technology Co.,Ltd.  
Corporation AND SHOULD  
NOT BE USED IN WHOLE  
PRIOR WRITTEN PERMISSION.

PDWG NO: 0383-1

**bbJconn** 深圳市步步精科技有限公司

.X: ±0.38 .X': ±3'  
.XX: ±0.25 .X'': ±2'  
.XXX: ±0.13 .XX': ±1'

APPD JM\_Zheng

CHKD LYX

DR LP

NAME: USB 2.0 AF 180度 H=10.00 兩腳直插 端子SMT  
平口 LCP黑膠 銅殼 端子鍍金3u

PJ NO: UB.01.52-12-V003

SIZE:A4 DRW NO:

FINISH:SEE NOTES MAT'L:SEE NOTES

SCALE:N/A REV:A0 UNIT:mm PAGE:2/2