

REV.	ECN NO	CONTENT	DATE	ENGINEER
AO			2023 20/04	

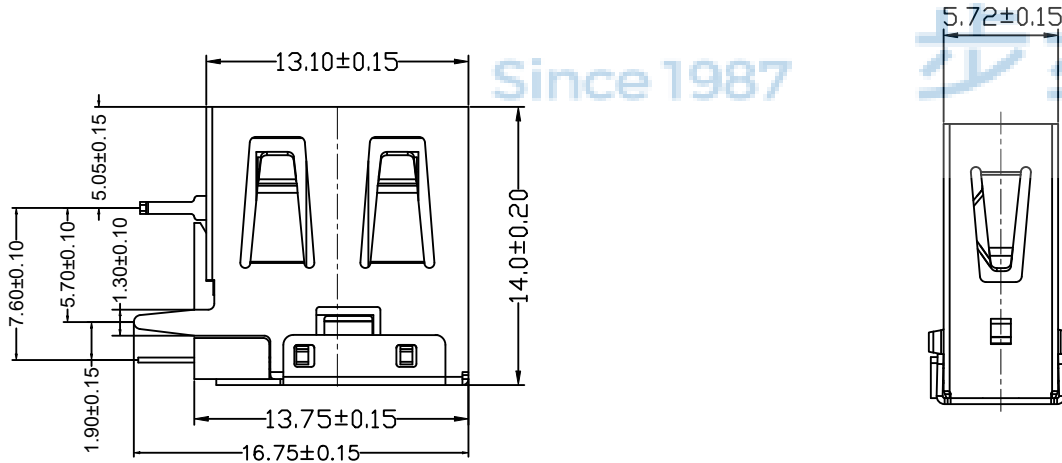
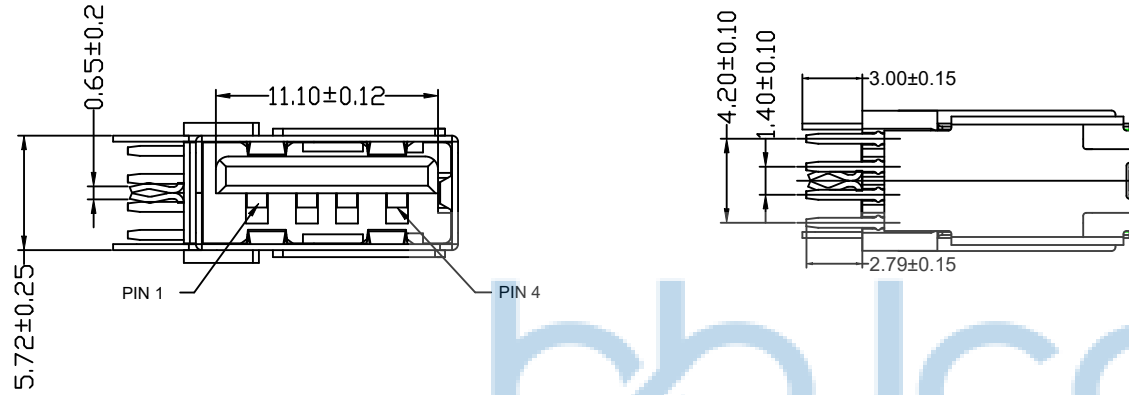

规格说明: Specifications:

电气特性: Electrical:

1. 额定电流: Current Rating
1.5A/contact terminal
2. 额定电压: Voltage Rating
30V DC
3. 接触阻抗: Contact Resistance
30 milliohms MAX
4. 耐压: Dielectric Withstanding Voltage:
500 V AC AT Sea Level
5. 绝缘阻抗: Insulation Resistance:
1000MEGA ohms MIN

物理性能: Mechanical:

1. 插拔力: Connector Mate and Unmate Force
Mate force: 3.57kgf (MAX)
Unmate force: 1.02kgf (MIN)
2. 端子保持力: Terminal Retention
1.0kgf (MIN)

原材料: Material:

Hing Temperature Thermoplastics,

2. 端子: Contact: Copper Alloy C2680

3. 外壳: Shell: Copper Alloy C2680/SPCC

电镀: Finish:

1. 端子: Contact: Plated Gold in Mating Area;
Tin On Solder Talls

端子四周镀50U" (MIN) 锡, 镀金区域镀100-200U" 镀金1U"

2. 外壳: Shell:

铜壳四周镀80U" (MIN) 锡

Nickel Plating

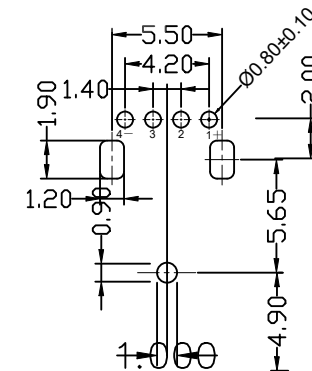

RECOMMEND PCB LAYOUT



THIS DOCUMENT IS THE SOLE PROPERTY OF BBJconn Technology Co., Ltd.		深圳市步步精科技有限公司	
Corporation AND SHOULD NOT BE USED IN WHOLE OR IN PART WITHOUT PRIOR WRITTEN PERMISSION.	.X ±0.20 .XX ±0.10 .XXX ±0.05	X' ±3" .X' ±2" .XX' ±1"	NAME: USB 2.0 母座 侧插 DIP L=14.0 直脚O型 平口 LCP本色 铁壳
PDWG.NO: 0383-1	DR. ZY	23/05'02	PJ. NO.: UB.01.42-91-V001 SIZE: A4 DRW NO.:
			FINISH: SEE NOTES SCALE: N/A
			MAT'L.: SEE NOTES REV.: A3
			UNIT: mm PAGE: 1/1

REV.	ECN NO	CONTENT	DATE	ENGINEER
A0			2023 20/04	

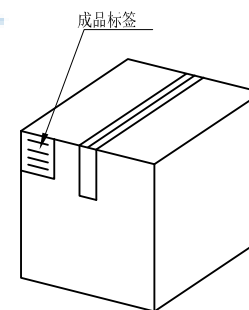
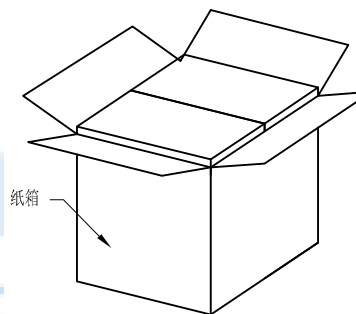
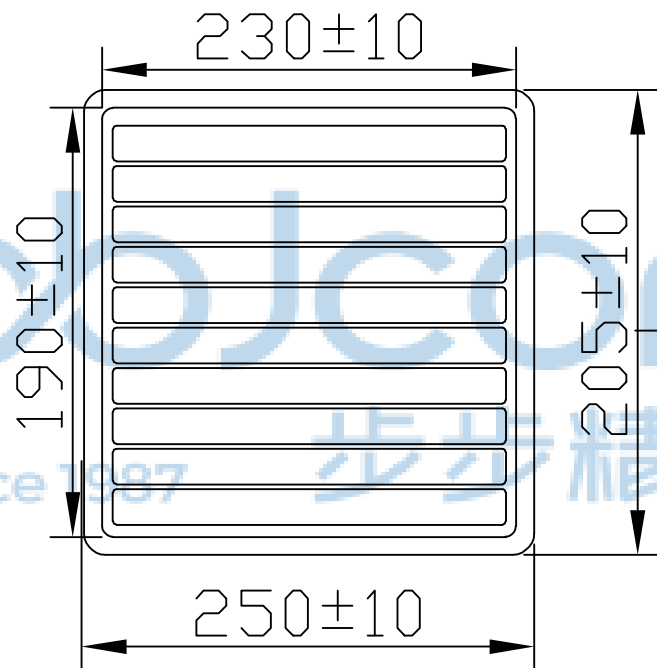

纸箱规格: 350*210*29

1. 包装要求:

- 1.1 每盒吸塑盒包装100 pcs;
- 1.2 纸箱外贴上标签



THIS DOCUMENT IS THE SOLE PROPERTY OF BBJconn Technology Co.,Ltd. Corporation AND SHOULD NOT BE USED IN WHOLE OR IN PART WITHOUT PRIOR WRITTEN PERMISSION.		深圳市步步精科技有限公司 .X: ±0.38 .XX: ±0.25 .XXX: ±0.13 X': ±3" X'': ±2" XX': ±1"		NAME: USB 2.0 母座 侧插 DIP L=14.0 直脚0型 平口 LCP本色 铁壳 PJ. NO.: UB.01.42-91-V001 SIZE: A4 DRW NO.: FINISH: SEE NOTES MAT'L.: SEE NOTES SCALE: N/A REV.: A3 UNIT: mm PAGE: 1/1	
PDWG.NO: 0383-1	DR. ZY	23/05'02			