

REV.	ECN NO	CONTENT	DATE	ENGINEER
A0		Initial release	/	GZY

规格说明: Specifications:

电气特性: Electrical:

1. 额定电流: Current Rating
1.5A/contact terminal
2. 额定电压: Voltage Rating
30V DC
3. 接触阻抗: Contact Resistance
30 milliohms MAX
4. 耐电压: Dielectric Withstanding Voitage:
500 V AC AT Sea Level
5. 绝缘阻抗: Insulation Resistance:
1000MEGA ohms MIN

物理性能: Mechanical:

1. 插拔力: Connector Mate and Unmate Force
Mate force: 3.57kgf(MAX)
Unmate force: 1.02kgf(MIN)
2. 端子保持力: Terminal Retention
1.02kgf(MIN)

原材料: Material:

1. 塑胶: Housing: lcp
Hing Temperature Ternmaplastics,
2. 端子: Contact: phosphorous copper
3. 外壳: Shell: Copper Alloy C2680

电镀: Finish:

1. 端子: Contact: 端子镀: 半金镀G/F
2. 外壳: Shell: 盐雾24H 外壳四周镀80U”(MIN)镍

Nickel Plating

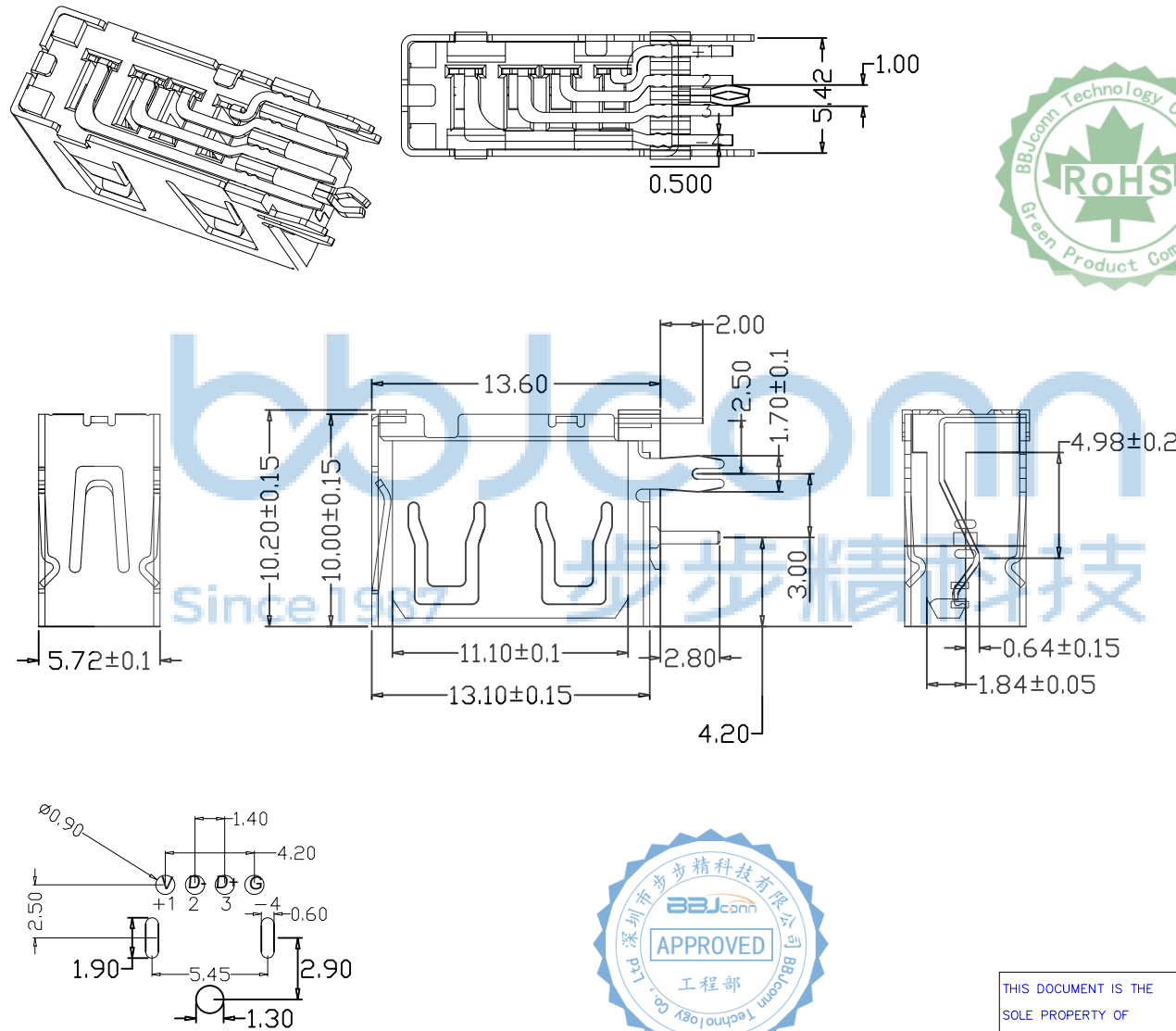

THIS DOCUMENT IS THE SOLE PROPERTY OF BBJconn Technology Co., Ltd. Corporation AND SHOULD NOT BE USED IN WHOLE OR IN PART WITHOUT PRIOR WRITTEN PERMISSION.		深圳市步步精科技有限公司 APPD. JM_Zheng CHKD. LYX DR. GZY		NAME: USB 2.0 母座 短体 90度 三脚插 侧插 端子DIP L=10.0 平口 铜壳 磷铜端子 LCP本色 盒装 PJ. NO.: 127-272-040112-W7G SIZE: A4 DRW NO.: FINISH: SEE NOTES MAT'L.: SEE NOTES SCALE: N/A REV.: A0 UNIT: mm PAGE: 1/2	
PDWG.NO: 0383-1		.X: ±0.38 .XX: ±0.25 .XXX: ±0.13	X': ±3" .X': ±2" .XX': ±1"		

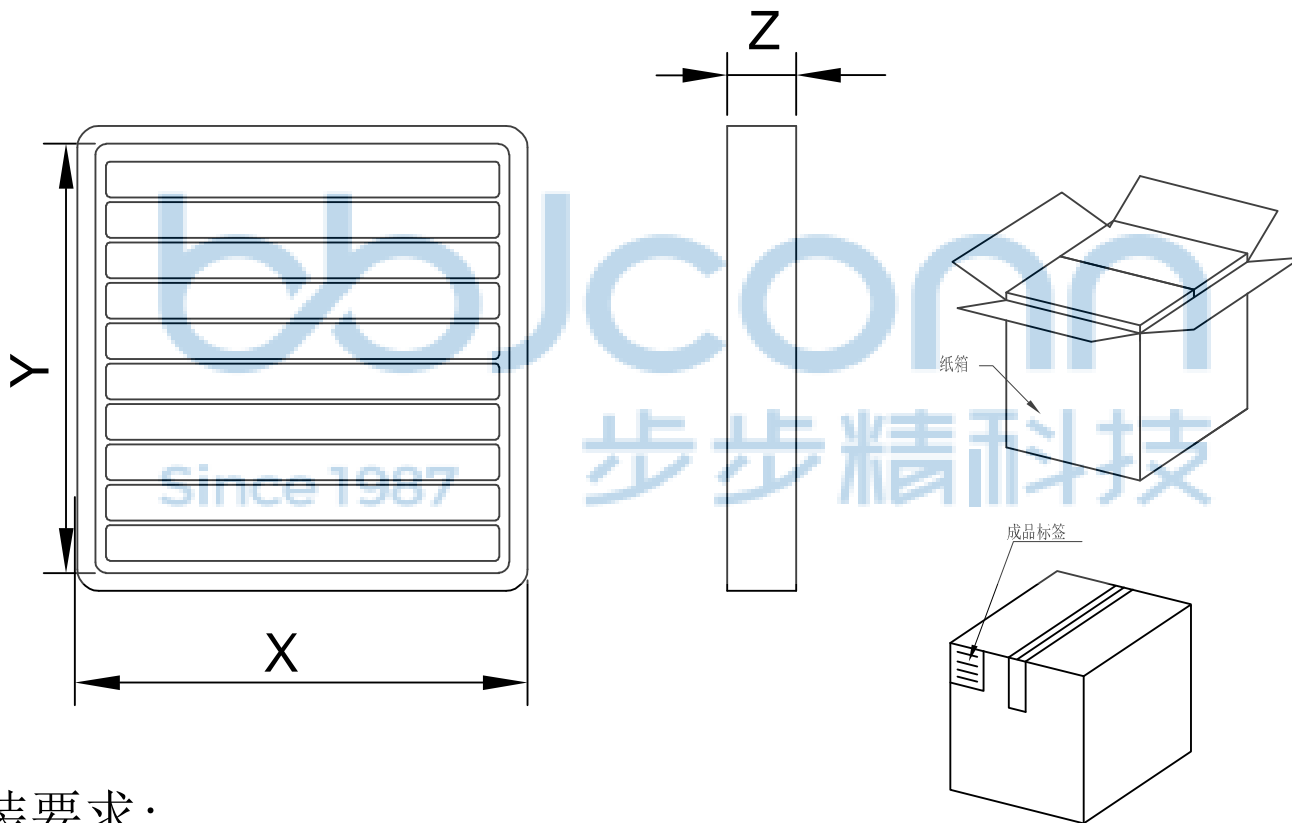

1. 包装要求:
- 1.1 每盒吸塑盒包装100pcs;
 - 1.2 每20盘放一箱, 共计2000PCS;
 - 1.3 纸箱外贴上标签。

纸箱规格: 350*210*290

THIS DOCUMENT IS THE SOLE PROPERTY OF BBJconn Technology Co.,Ltd. Corporation AND SHOULD NOT BE USED IN WHOLE OR IN PART WITHOUT PRIOR WRITTEN PERMISSION.		深圳市步步精科技有限公司 .X: ±0.38 .X': ±3" .XX: ±0.25 .X'': ±2" .XXX: ±0.13 .XX': ±1"		NAME: USB 2.0 母座 短体 90度 三脚插 侧插 端子DIP L=10.0 平口 铜壳 磷铜端子 LCP本色 盒装	
APPD.	JM_Zheng	PJ. NO.: 127-272-040112-W7G SIZE: A4 DRW NO.:		FINISH: SEE NOTES MAT'L.: SEE NOTES	
CHKD.	LYX	DR.		GZY	SCALE: N/A REV.: A0 UNIT: mm PAGE: 2/2
PDWG.NO: 0383-1					