



REV.	DESCRIPTION	NAME	DATE
A	NEWS ISSUE		

规格说明: Specifications:

电气特性: Electrical:

1. 额定电流: Current Rating  
3A/contact terminal
2. 额定电压: Voltage Rating  
30V DC
3. 接触阻抗: Contact Resistance  
30 milliohms MAX
4. 耐电压: Dielectric Withstanding Voltage:  
500 V AC AT Sea Level
5. 绝缘阻抗: Insulation Resistance:  
1000MEGA ohms MIN

物理性能: Mechanical:

1. 插拔力: Connector Mate and Unmate Force  
Mate force: 3.57kgf (MAX)  
Unmate force: 1.02kgf (MIN)
2. 端子保持力: Terminal Retention  
1.2kgf (MIN)

原材料: Material:

1. 塑胶: Housing:  
Hing Temperature Thermoplastics,
2. 端子: Contact:  
Copper Alloy C2680
3. 外壳: Shell: SPCC/C2680

电镀: Finish:

1. 端子: Contact: Plated Gold in Mating Area;  
Tin On Solder Talls
2. 外壳: Shell: Nickel Plating

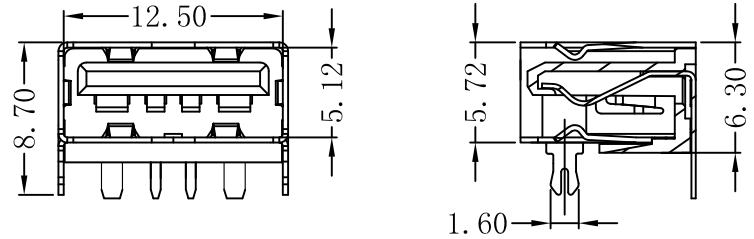

SECTION A-A

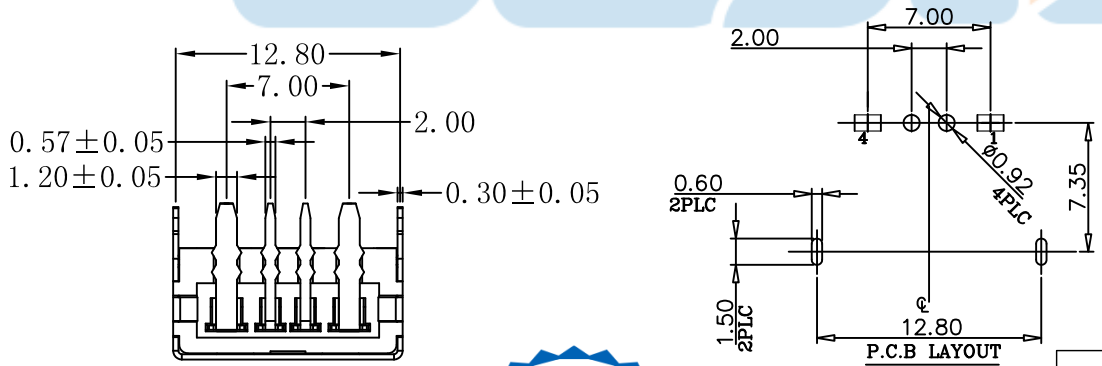
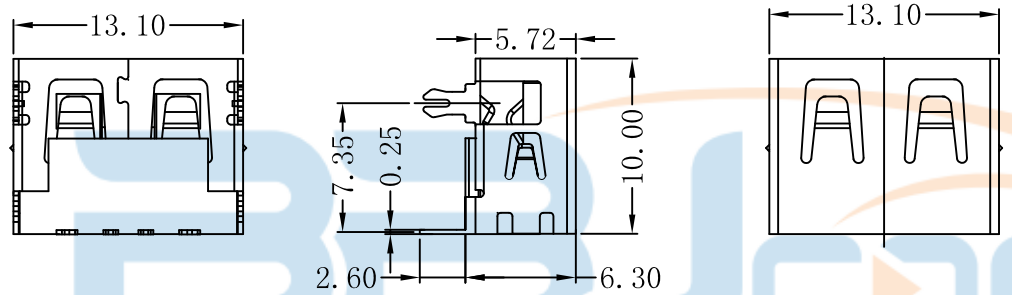

TOLERANCE UNSPECIFIED	
.0	±0.35
.00	±0.25
.000	±0.15
X.°	±2.00°
CUSTOMER DRAWING	

**深圳市步步精科技有限公司**

TITLE: USB 2.0 AF 90度 短体L=10.0 H=6.3 前两脚后插DIP 平口 PBT蓝胶 铁壳 大电流3A

DRAWN/ DATE	设计 TSP	SIZE: A4	UNIT: MM.	PART. NO:
CHECKED/ DATE	审核 LYX	SCALE: 1:1	PROJECTION	REV.: 版本
APPROVED/ DATE	核准 LJP	DWG. PATH	0383-1	SHEET: 页码

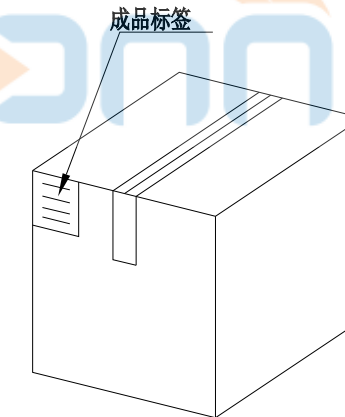
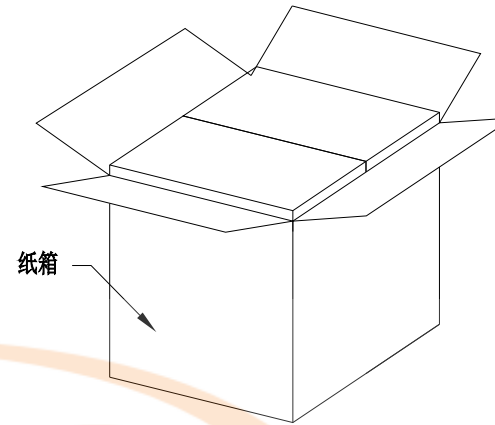
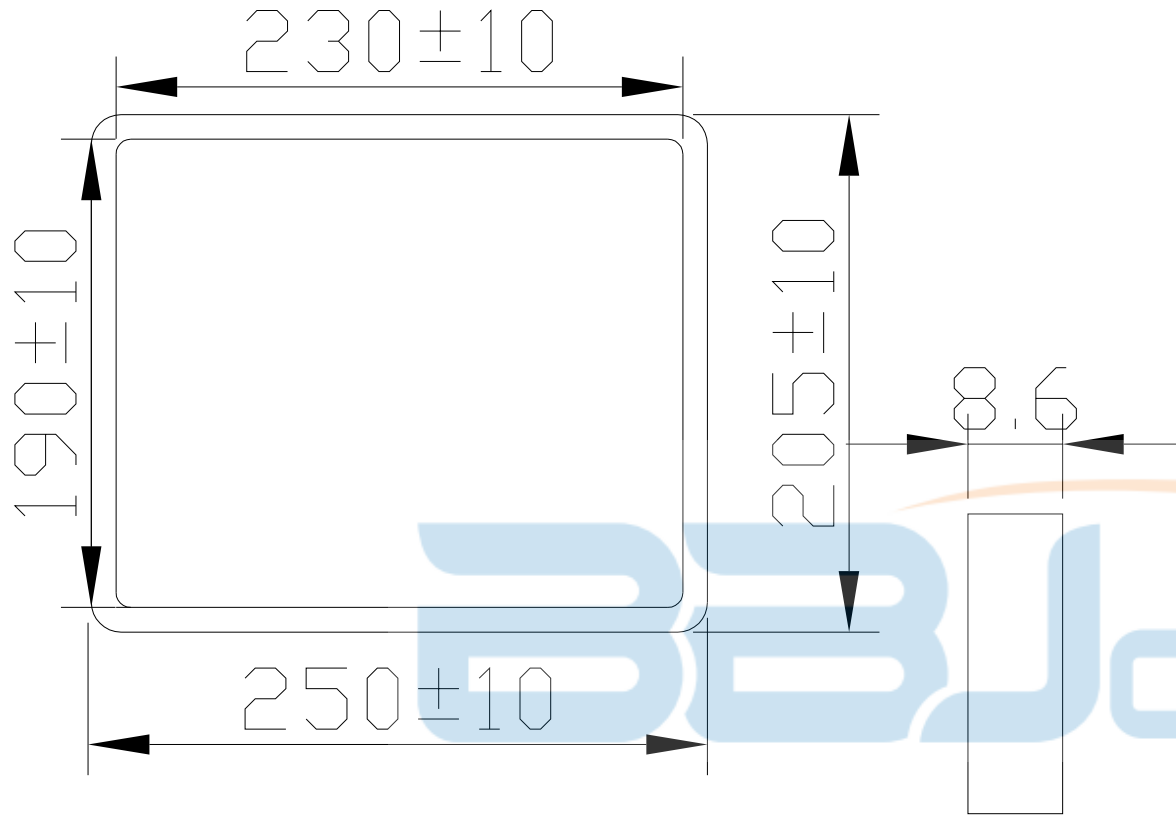

纸箱规格：350\*210\*290

1. 包装要求:

- 1.1 每盒吸塑盒包装100pcs;
- 1.2 每20盘放一箱，共计2000PCS;
- 1.3 纸箱外贴上标签



TOLERANCE UNSPECIFIED		深圳市步步精科技有限公司 TITLE: USB 2.0 AF 90度 短体L=10.0 H=6.3 前两脚后插DIP 平口 PBT蓝胶 铁壳 大电流3A						
.0	±0.35	DRAWN/	设计	TSP	SIZE:A4	UNIT:MM.	PART. NO:	
.00	±0.25	DATE						
.000	±0.15	CHECKED/	审核	LYX	SCALE: 1:1	PROJECTION		REV.: 版本
X.°	±2.00°	DATE			DWG. PATH			SHEET: 页码
CUSTOMER DRAWING		APPROVED/	核准	LJP			0383-1	
		DATE						