

RECOMMENDED P. C. B HOLE LAYOUT
COMPONENT SIDE VIEW (TOLERANCE: +/-0.05)

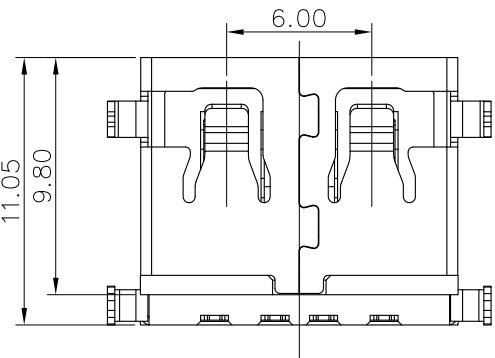
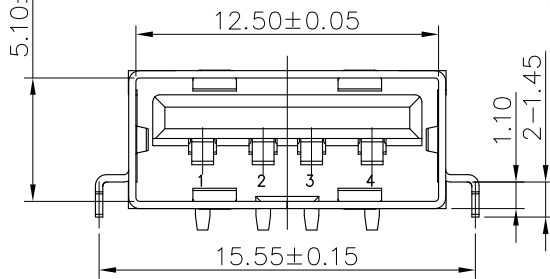
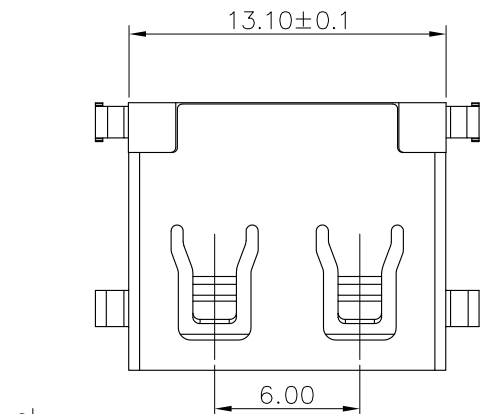
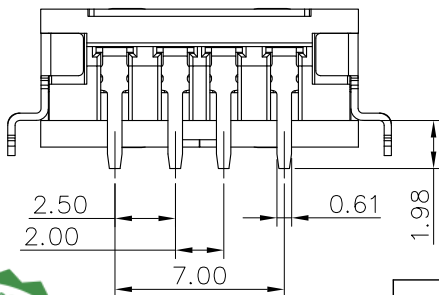
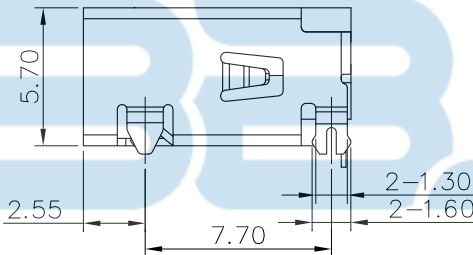

NOTES:

- MATERIAL**
CONTACTS: COPPER ALLOY (T=0.20mm)
SHELL: SPCC OR COPPER(T=0.30mm)
HOUSING: HIGH TEMPERATURE RESISTANT PLASTIC, UL94 V-0.
- ELECTRICAL PERFORMANCE**
CONTACT RESISTANCE: 30MΩ MAX
CONTACT CURRENT RATING: 1.5 AMPERES
DIELECTRIC WITHSTAND VOLTAGE, 500V R. M. S
INSULATION RESISTANCE: 100MΩ MIN
OPERATING TEMPERATURE: -40° C~+85° C.
- MECHANICAL PERFORMANCE**
INSERTION FORCE: 3.5kgf Max
REMOVAL FORCE: 1.02kgf Min
DURABILITY: 5000 CYCLES.
- PLATING SPECIFICATION:**
CONTACTS: GOLD PLATED ON CONTACT AREA, Sn ON SOLDER AREA, NICKEL UNDERPLATED.
SHELL: 80u"MIN BRIGHT NICKEL PLATING OVER ALL, NICKEL MUST BE SOLDABILITY.
HOUSING: HIGH TEMPERATURE RESISTANT PLASTIC, UL94 V-0 .

REV.	DESCRIPTION	NAME	DATE
A	NEWS ISSUE		

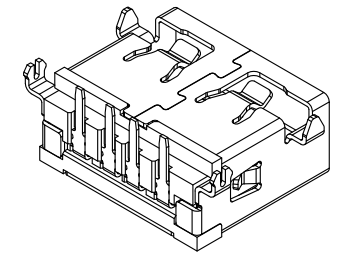
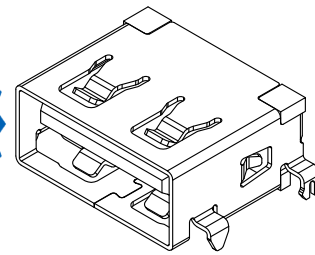

TOLERANCE UNSPECIFIED

.0	±0.35
.00	±0.25
.000	±0.15
X. °	±2.00°

CUSTOMER DRAWING

深圳市步步精科技有限公司

TITLE: USB 2.0 AF 90度L=11.05 四脚插沉板1.1 (端子DIP) 平口 铁壳 LCP黑胶

Number	Signal Name
1	VBUS
2	D-
3	D+
4	GND

DRAWN/ DATE	设计 HMY	SIZE:A4	UNIT:MM.	PART. NO:
CHECKED/ DATE	审核 LYX	SCALE: 1:1	PROJECTION	REV.: 版本
APPROVED/ DATE	核准 LJP	DWG. PATH	0100-2	SHEET: 页码



一.
將成品依同一方向放入真空盤內,如圖所示。
At same direction, put product onto the tray. Direction refers to below drawing.

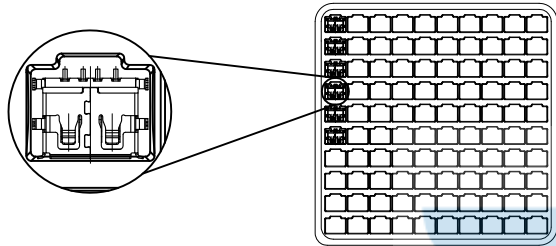

VIEW-1

- 二.
- 1) 一只紙箱可放置之包裝盤(包括上蓋)見下表。
1) trays per carton, please see next table.
 - 2) 最上面一個真空盤作為上蓋,故不放置成品.貼上標籤。
2) Put cover on the top tray to protect product. Sticking Show.
 - 3) 每1個紙箱用的包裝數量詳見下表。
3) The Q'ty of products per carton please see next tabel.

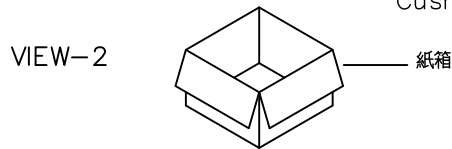
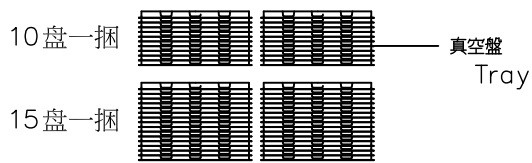

VIEW-2



- 4) 將裝滿成品的真空盤用 PE帶捆緊後放在塑膠袋內,裝完後再封箱。
4) Bind the trays with PE tape and then, put them into the poly bag. Seal the carton with tape.

三.

- 1) 將標籤貼於紙箱側麥上方。
Stick the needful label On the up-right corner of the side of carton.

標籤黏貼處
Location of Sticking lable

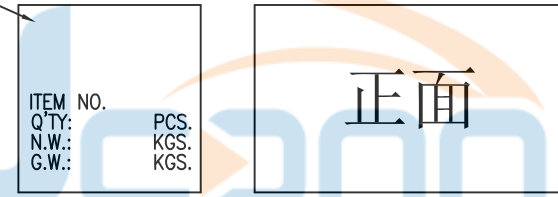

VIEW-3

備 註(REMARK)

1. 若有未裝滿之零數箱,必須以緩衝材塞滿。
The unfilling-carton must be filled with assuagement.
2. 裝滿成品后之外箱,最大堆積箱數:5箱
About the box fully filled with products, the MAX accumulating quantity of boxes is 5.
3. 如須貼Bar-code,請依Bar-code作業辦法執行
If barcode lable is required, do it according to the related barcode lable operation standards.

包裝明細表 (The detail of the packing) Carton						
產品料號 (Product No.)	包裝容量 (Packing Capacity)			重量 Weight (Kg)		
	pcs/box	boxs/Carton	Pcs/Box	N. W. /Pcs	N. W. /Box	G. W. /Box
	100	50	5000			

TOLERANCE UNSPECIFIED		深圳市步步精科技有限公司 TITLE: USB 2.0 AF 90度L=11.05 四脚插沉板1.1 (端子DIP) 平口 铁壳 LCP黑胶				
.0	±0.35	DRAWN/ DATE	设计 HMY	SIZE: A4	UNIT: MM.	PART. NO:
.00	±0.25	CHECKED/ DATE	审核 LYX	SCALE: 1:1	PROJECTION	REV.: 版本
.000	±0.15	APPROVED/ DATE	核准 LJP	DWG. PATH	0100-2	SHEET: 页码
X.°	±2.00°	CUSTOMER DRAWING				