

REV.	ECN NO	CONTENT	DATE	ENGINEER
A0		Initial release	/	TSP

NOTES:
 1.MATERIAL:
 MOLDING: LCP E130I UL94 V-0
 CONTACT: C7025 T=0.15
 Au30u" PLATED ON CONTACT AREA,
 GOLD FLASH ON SOLDER AREA,
 NICKEL 50U" UNDERPLATING OVER ALL.
 SHELL: SUS304-H,T=0.30±0.03mm
 30u" NICKEL PLATING OVER ALL.
 MIDDLE SHILD: SUS304-H,T=0.20±0.03mm
 2.MECHANICAL:
 INSERTION: 5~20N.
 EXTRACTION: 8~20N AFTER TEST.
 DURABILITY: 10000 CYCLES
 3.ELECTRICAL:
 CURRENT: 5A FOR VBUS;
 1.25A FOR GND PIN.
 0.25A FOR OTHER.
 VOLTAGE: 20 V MAX
 WITHSTANDING VOLTAGE: 100V AC R.M.S.
 CONTACT RESISTANCE: 40mΩ MAX.
 INSULATION RESISTANCE: 100MΩ MIN.
 4.ENVIRONMENTAL
 TEMPERATURE RANGE -35°C ~ +85°C

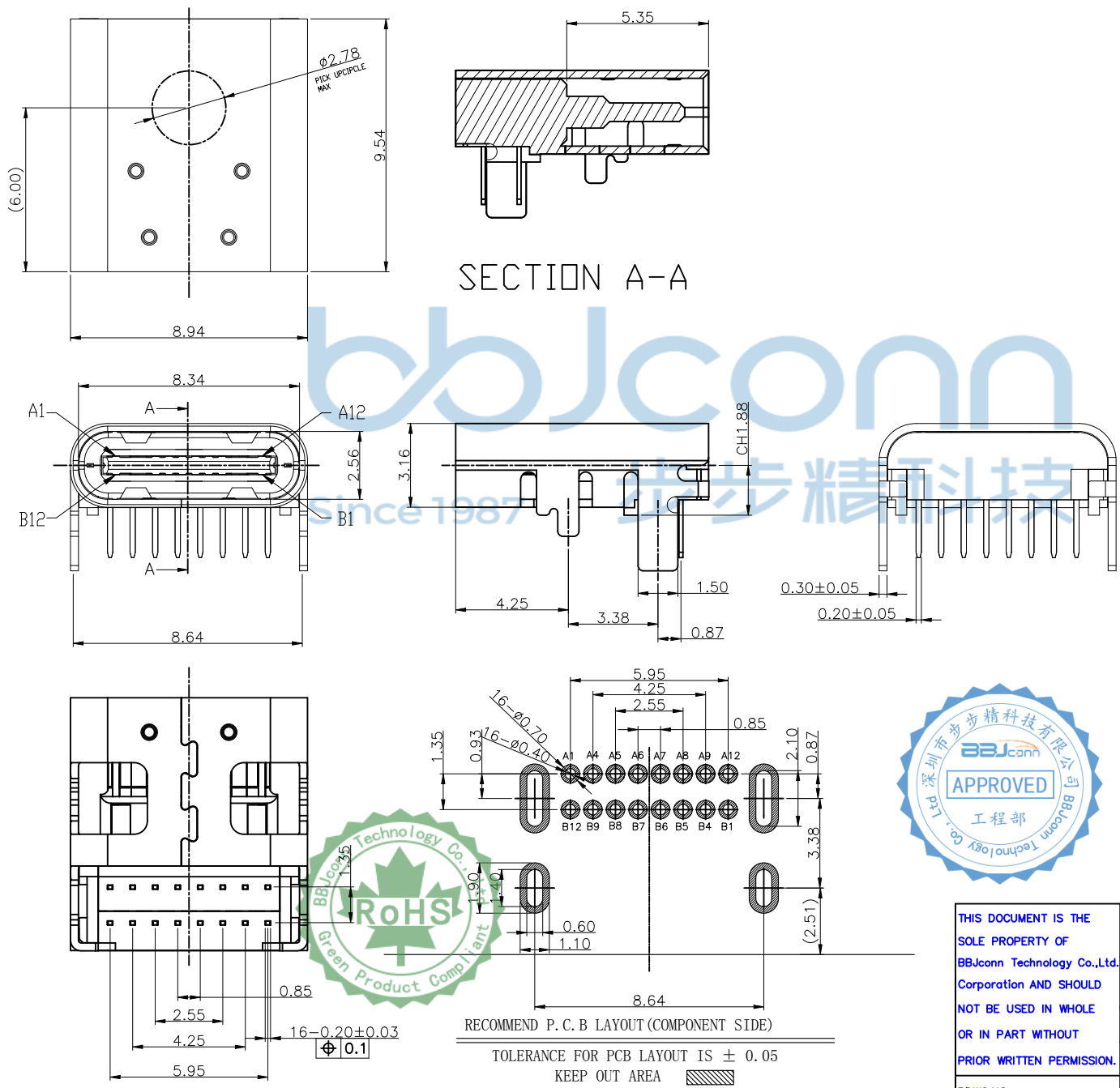

USB TYPE-C PIN ASSIGNMENTS

PIN NUMBER	SIGNAL NAME	PIN NUMBER	SIGNAL NAME
A1	GND	B12	GND
A4	Vbus	B9	Vbus
A5	CC1	B8	SBU2
A6	Dp1	B7	Dn2
A7	Dn1	B6	Dp2
A8	SBU1	B5	CC2
A9	Vbus	B4	Vbus
A12	GND	B1	GND

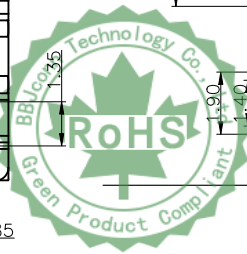

THIS DOCUMENT IS THE SOLE PROPERTY OF BBJconn Technology Co.,Ltd. Corporation AND SHOULD NOT BE USED IN WHOLE OR IN PART WITHOUT PRIOR WRITTEN PERMISSION.

PDWG.NO: 0627-1

APPD. JM_Zheng
CHKD. LYX
DR. TSP

深圳市步步精科技有限公司

NAME: TYPE-C 16P 母座 L=9.54 CH=1.88
板上四脚插 双排DIP 端子脚长1.60 端子镀金30u

PJ. NO.: UC.01.11-1W-0013
SIZE: A4 DRW NO.:

FINISH: SEE NOTES MAT'L.: SEE NOTES
SCALE: N/A REV.: A0 UNIT: mm PAGE: 1/2

REV.	ECN NO	CONTENT	DATE	ENGINEER
A0		Initial release	/	TSP

出料方向
PULL OUT DIRECTED

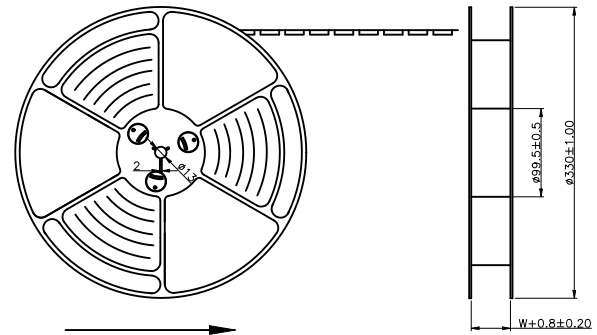

NOTES

- 帶子引導長度
LEAD TAPE LENGTH
出料方向
PULL OUT DIRECTED

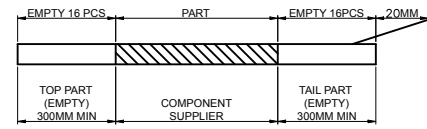

- 上帶剝力為: 0.1-1.3N(10.2gf~130gf)
PEELING OFF FORCE OF TOP TAPE: 0.1~1.3N(10.2gf~130gf)
出貨運輸過程中一定要注意:
THIS REQUIREMENT SHOULD BE APPLIED AT SHIPMENT:
卷帶在運輸過程中不能散開
PEELING OFF SHOULD NOT BE ALLOWED DURING TRANSPORTATION

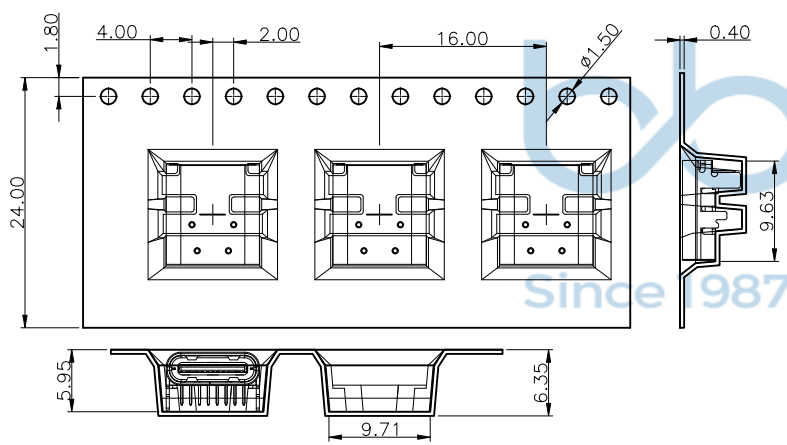
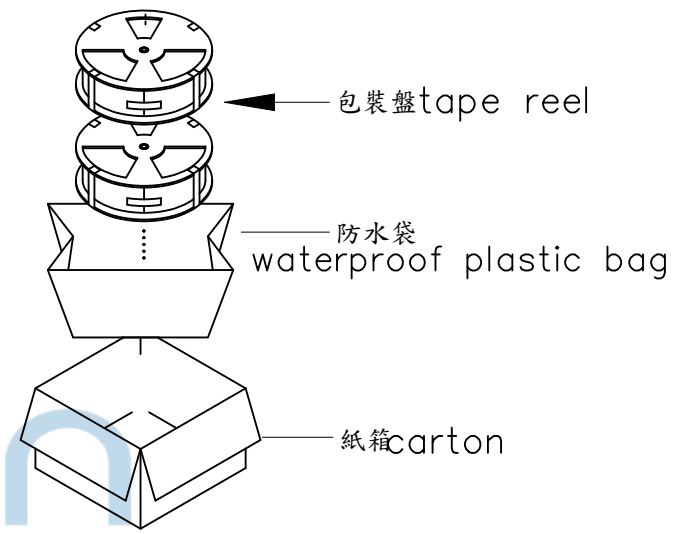

載帶卷料方向

at small positioning hole of the carrier tape side.
標籤黏貼處 (朝捲裝包材的小定位孔一側)
Location of label sticking (label)

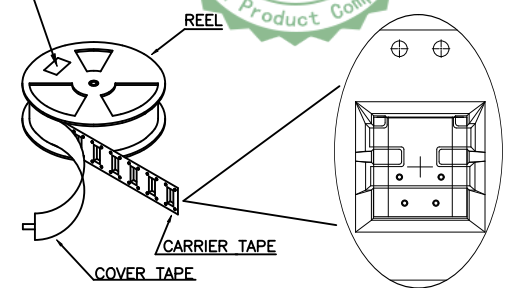

NOTE:

- 每捲包裝數量及每箱裝箱數量如左下表。
- 以上膠帶覆蓋下包裝帶經包裝機冷封包裝
- 每個紙箱放2個珍珠棉
- 將裝滿產品的卷盤放入紙箱並以膠帶封口

包裝容量 (PACKING CAPACITY)			重量 WEIGHT (Kg)		
PCS/REEL	REELS/CARTON	PCS/CARTON	N.W./PCS	N.W./BOX	G.W./BOX
700	10	7000			

THIS DOCUMENT IS THE SOLE PROPERTY OF BBJconn Technology Co.,Ltd. Corporation AND SHOULD NOT BE USED IN WHOLE OR IN PART WITHOUT PRIOR WRITTEN PERMISSION.

PDWG:NO: 0627-1

深圳市步步精科技有限公司

NAME: TYPE-C 16P 母座 L=9.54 CH=1.88
板上四脚插 双排DIP 端子脚长1.60 端子镀金30u

PJ. NO.: UC.01.11-1W-0013
SIZE: A4 DRW NO.:

FINISH: SEE NOTES MAT'L.: SEE NOTES
SCALE: N/A REV.: A0 UNIT: mm PAGE: 2/2

APPD.	JM_Zheng
CHKD.	LYX
DR.	TSP