

REV.	ECN NO	CONTENT	DATE	ENGINEER
A0		Initial release	/	GZY

NOTE:

- MATERIAL:
  - INSULATOR:HIGH TEMPERATURE PLASTIC
  - CONTACT:BRONZE
  - SHELL:STAINLESS STEEL
- ELECTRICAL CHARACTERISTICS;
  - CONTACT RESISTANCE:30mΩ MAX
  - CONTACT CURRENT RATING:1.8A
  - DIELECTRIC WITHSTANDING VOLTAGE:100 V R. M. S.
  - INSULATION RESISTANCE 100 MΩ MIN
  - OPERATING TEMPERATURE:-40° C ~ 85° C
- MECHANICAL CHARACTERISTICS:
  - MATING FORCE:3.5kgf MAX.
  - UNMATING FORCE:1.0kgf~2.5kgf.
  - DURABILITY:MANDATORY:5,000 CYCLES
- PLATING
  - TERMINAL:
    - 50u" MIN NICKEL ALL OVER
    - 100u"MIN Tin ON SOLDER AREA
    - (1~30)u"Au ON CONTACT AREA
  - SHELL:80u"MIN. NICEL ALL OVER
- PART NO.

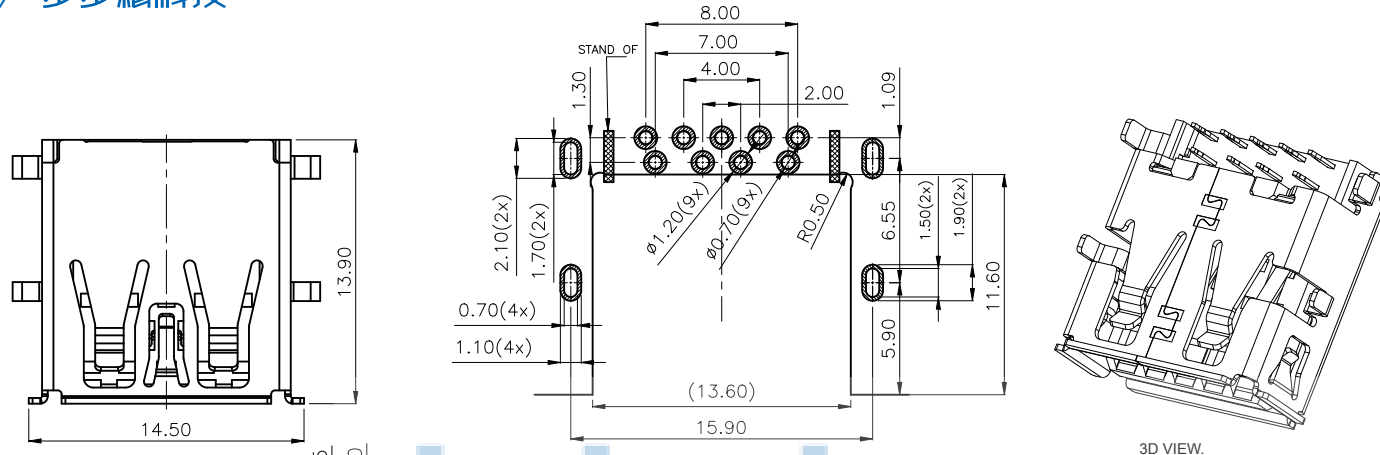

RECOMMENDED P.C.B LAYOUT, T=1.0mm  
P.C.B TOLERANCES ±0.05mm

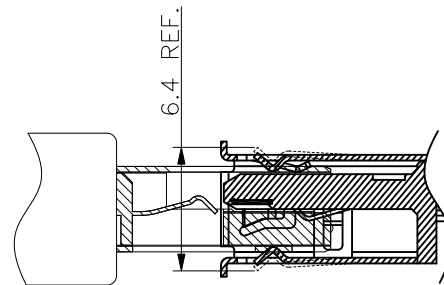
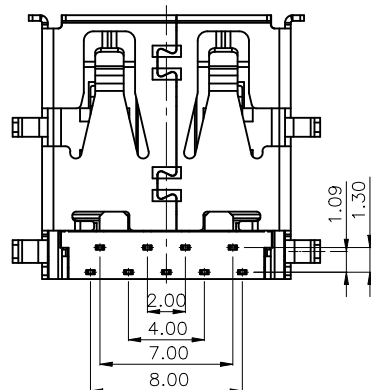
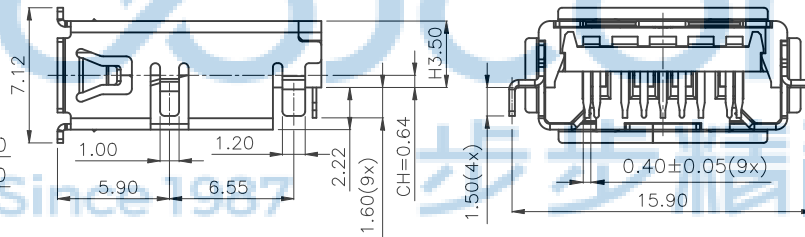
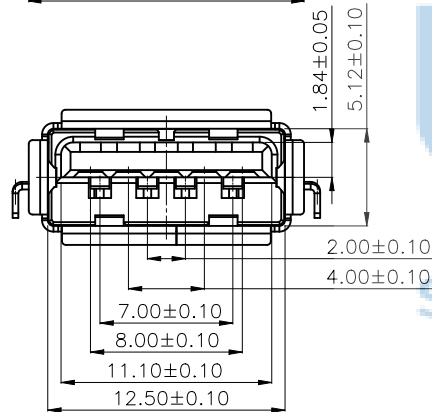

公母對插圖



THIS DOCUMENT IS THE SOLE PROPERTY OF BBJconn Technology Co.,Ltd. Corporation AND SHOULD NOT BE USED IN WHOLE OR IN PART WITHOUT PRIOR WRITTEN PERMISSION. PDWG.NO: 0536-1		 <b>深圳市步步精科技有限公司</b>	
.X: ±0.38	.X': ±3'	NAME: USB 3.1 AF 90度 外壳四脚DIP 端子DIP L=13.9 沉板2.22 CH=0.64 外壳脚距15.9 卷边 端子脚长1.60 不锈钢外壳 镀金足1u 编带	
.XX: ±0.25	.X': ±2'	APPD. JM_Zheng	PJ. NO.: 127-272-090009-P2G
.XXX: ±0.13	.XX': ±1'	CHKD. LYX	SIZE: A4 DRW NO.:
		DR. GZY	FINISH: SEE NOTES MAT'L.: SEE NOTES
			SCALE: N/A REV.: A0 UNIT: mm PAGE: 1/2

REV.	ECN NO	CONTENT	DATE	ENGINEER
A0		Initial release	/	GZY

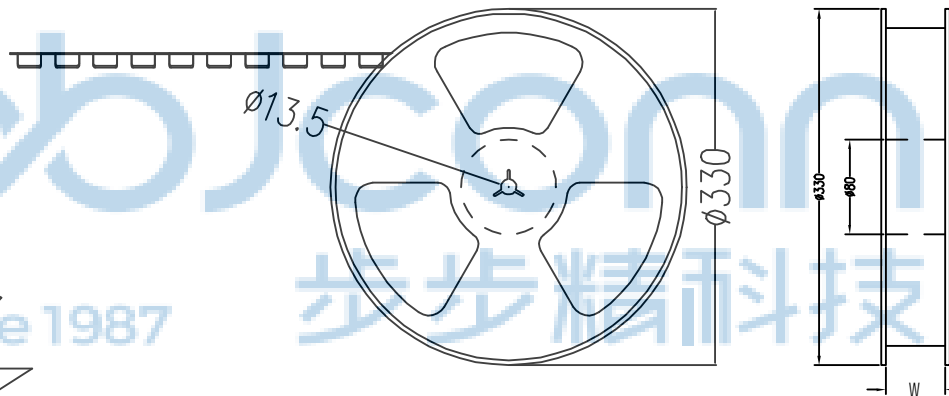
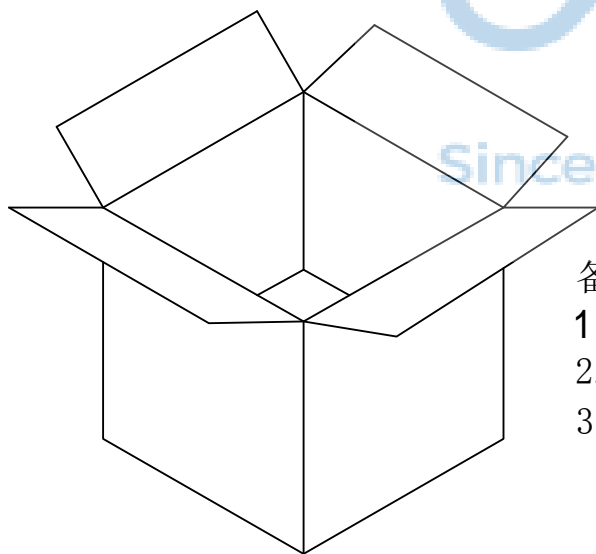
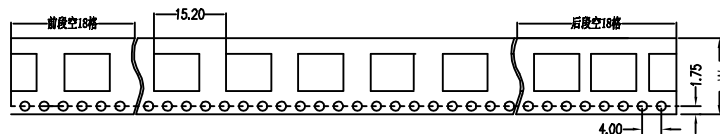
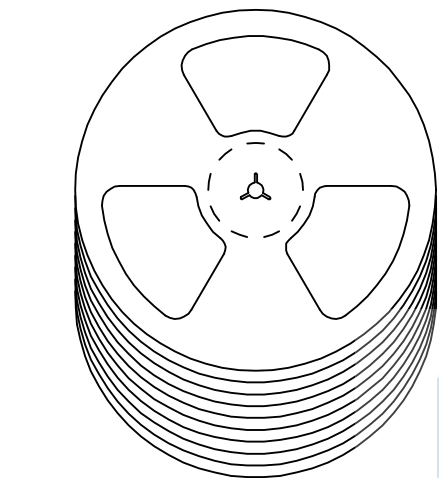

备注:

1. 包装数量：400/PCS/卷，10卷/箱
2. 包装袋长度：每卷前后各空10-20个空格，中间包装。
3. 材质：  
载体：聚丙烯（PS），  
上带：聚乙烯（PET），  
卷盘：聚苯乙烯。

纸箱规格：345\*345\*230MM

纸箱规格：345\*345\*350MM

THIS DOCUMENT IS THE SOLE PROPERTY OF BBJconn Technology Co.,Ltd. Corporation AND SHOULD NOT BE USED IN WHOLE OR IN PART WITHOUT PRIOR WRITTEN PERMISSION. PDWG,NO: 0536-1		<b>深圳市步步精科技有限公司</b>	
.X: ±0.38 .XX: ±0.25 .XXX: ±0.13		X': ±3" X'': ±2" XX': ±1"	
APPD.	JM_Zheng	NAME: USB 3.1 AF 90度 外壳四脚DIP 端子DIP L=13.9 沉板2.22 CH=0.64 外壳脚距15.9 卷边 端子脚长1.60 不锈钢外壳 镀金足1u 编带	
CHKD.	LYX	PJ. NO.: 127-272-090009-P2G	
DR.	GZY	SIZE: A4 DRW NO.:	
		FINISH: SEE NOTES MAT'L.: SEE NOTES	
		SCALE: N/A REV.: A0 UNIT: mm PAGE: 2/2	