

REV.	ECN NO	CONTENT	DATE	ENGINEER
A0		Initial release	/	SGF

SPECIFICATIONS

Current Rating: 1.5 Amps
 Insulation Resistance: 1000M Ω Min
 Contact Resistance: 20mΩ Max
 Withstanding Voltage: AC 500V
 Operation Temperature: -40° to +105°
 Contact Material: Brass
 Standard: PA6T
 Insulator Material: Polyester (UL 94V-0)
 Contact Plating: Gold Flash
 Max. Processing Temp: 240° C for 30-60 seconds
 (260° C for 5 seconds)

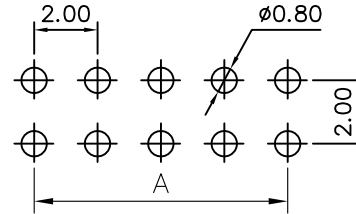
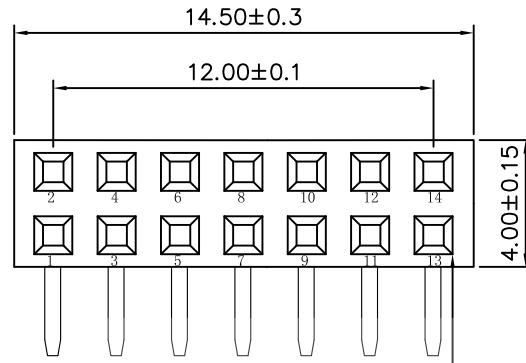

RECOMMEND P. C. B LAYOUT
 PCB TOLERANCE: ± 0.05 (TOP VIEW)

空第13P

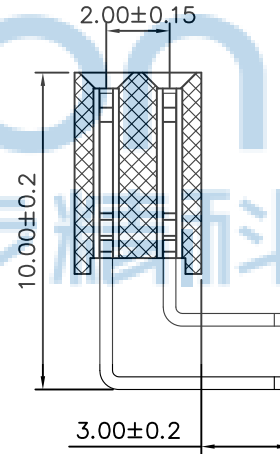
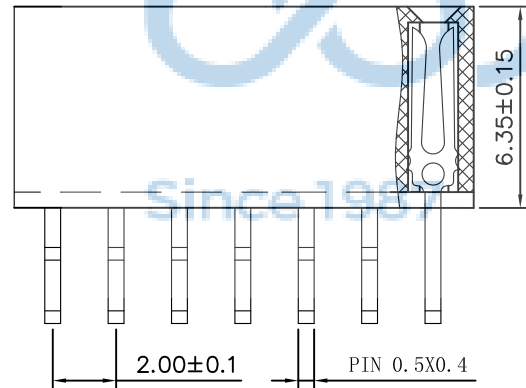

No. of	DIM. A	DIM. B	No. of	DIM. A	DIM. B	No. of	DIM. A	DIM. B	No. of	DIM. A	DIM. B
1	0.00	2.00	11	20.00	22.00	21	40.00	42.00	31	60.00	62.00
2	2.00	4.00	12	22.00	24.00	22	42.00	44.00	32	62.00	64.00
3	4.00	6.00	13	24.00	26.00	23	44.00	46.00	33	64.00	66.00
4	6.00	8.00	14	26.00	28.00	24	46.00	48.00	34	66.00	68.00
5	8.00	10.00	15	28.00	30.00	25	48.00	50.00	35	68.00	70.00
6	10.00	12.00	16	30.00	32.00	26	50.00	52.00	36	70.00	72.00
7	12.00	14.00	17	32.00	34.00	27	52.00	54.00	37	72.00	74.00
8	14.00	16.00	18	34.00	36.00	28	54.00	56.00	38	74.00	76.00
9	16.00	18.00	19	36.00	38.00	29	56.00	58.00	39	76.00	78.00
10	18.00	20.00	20	38.00	40.00	30	58.00	60.00	40	78.00	80.00



THIS DOCUMENT IS THE SOLE PROPERTY OF BBJconn Technology Co., Ltd. Corporation AND SHOULD NOT BE USED IN WHOLE OR IN PART WITHOUT PRIOR WRITTEN PERMISSION.		深圳市步步精科技有限公司 .X: ± 0.38 .X': $\pm 3'$.XX: ± 0.25 .X': $\pm 2'$.XXX: ± 0.13 .XX': $\pm 1'$		NAME: 排母 2.0FH H6.35 2x7P 90度 Y型 PC3.0 6T 空第13P PJ. NO.: FH.04.12-31-3005 SIZE: A4 DRW NO.: FINISH: SEE NOTES MAT'L.: SEE NOTES	
PDWG. NO: 0266-1	DR. SGF	APPD. JM_Zheng	CHKD. LYX	SCALE: N/A	REV.: A0
				UNIT: mm	PAGE: 1/1