

REV.	ECN NO	CONTENT	DATE	ENGINEER
A0		Initial release	/	SGF

**SPECIFICATIONS**

Current Rating: 1.0 Amps  
 Withstanding Voltage: AC 500V  
 Insulation Resistance: 1000MΩ Min  
 Contact Resistance: 20mΩ Max  
 Operation Temperature: -40° to+105°  
 Insulator Material: Polyester (UL94V-0)  
 Contact Material: Phosphor bronze  
 Standard: PA6T  
 Contact Plating: Gold Flash  
 Max. Processing Temp: 240° C for30-60seconds  
 (260° C for5seconds)

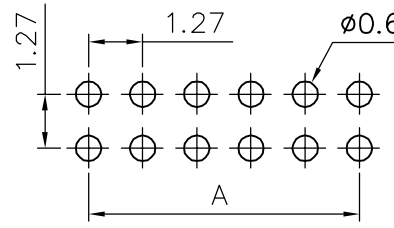
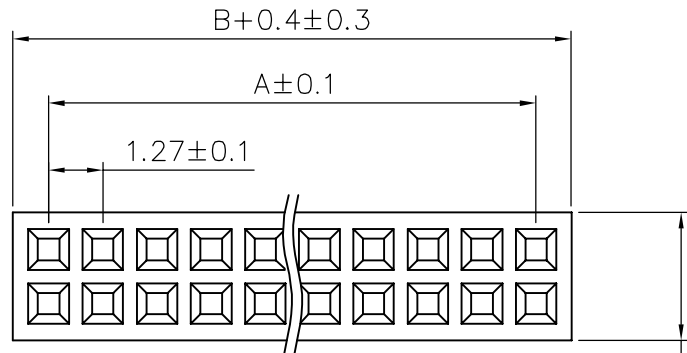

RECOMMEND P.C.B LAYOUT  
 PCB TOLERANCE: ±0.05 (TOP VIEW)

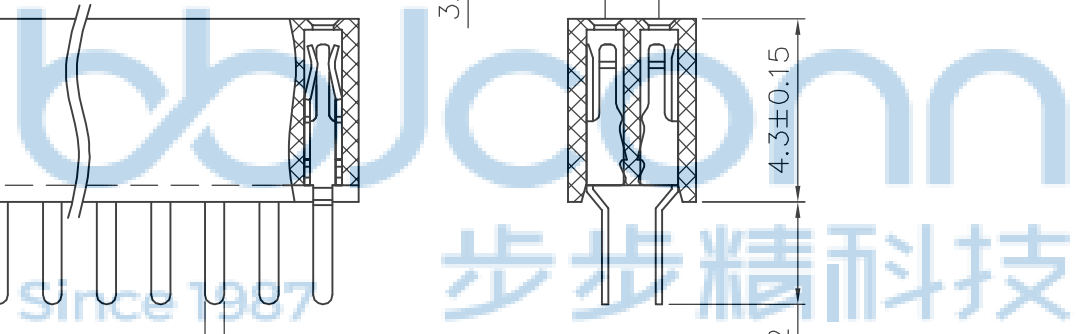
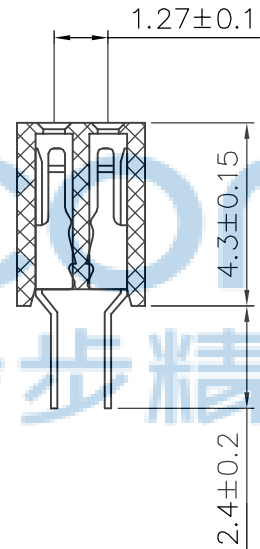
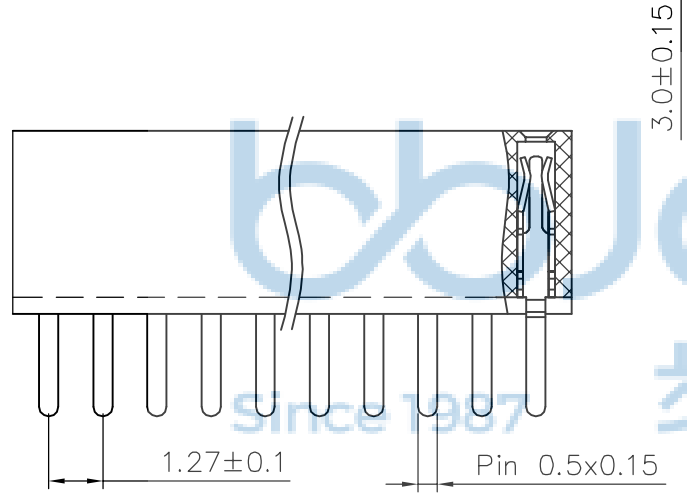

No. of	DIM. A	DIM. B	No. of	DIM. A	DIM. B	No. of	DIM. A	DIM. B	No. of	DIM. A	DIM. B	No. of	DIM. A	DIM. B
1	—	—	11	12.70	13.97	21	25.40	26.67	31	38.10	39.37	41	50.80	52.07
2	1.27	2.54	12	13.97	15.24	22	26.67	27.94	32	39.37	40.64	42	52.07	53.34
3	2.54	3.81	13	15.24	16.51	23	27.94	29.21	33	40.64	41.91	43	53.34	54.61
4	3.81	5.08	14	16.51	17.78	24	29.21	30.48	34	41.91	43.18	44	54.61	55.88
5	5.08	6.35	15	17.78	19.05	25	30.48	31.75	35	43.18	44.45	45	55.88	57.15
6	6.35	7.62	16	19.05	20.32	26	31.75	33.02	36	44.45	45.72	46	57.15	58.42
7	7.62	8.89	17	20.32	21.59	27	33.02	34.29	37	45.72	46.99	47	58.42	59.69
8	8.89	10.16	18	21.59	22.86	28	34.29	35.56	38	46.99	48.26	48	59.69	60.96
9	10.16	11.43	19	22.86	24.13	29	35.56	36.83	39	48.26	49.53	49	60.96	62.23
10	11.43	12.70	20	24.13	25.40	30	36.83	38.10	40	49.53	50.80	50	62.23	63.50

THIS DOCUMENT IS THE SOLE PROPERTY OF BBJconn Technology Co.,Ltd. Corporation AND SHOULD NOT BE USED IN WHOLE OR IN PART WITHOUT PRIOR WRITTEN PERMISSION.

PDWG.NO: 0266-1

APPD. JM\_Zheng  
 CHKD. LYX  
 DR. SGF

NAME: 深圳市步步精科技有限公司  
 排母 1.27FH H4.3 2x11P 180度 PC2.4 U型 6T 管装

PJ. NO.: FH.03.22-25-3002  
 SIZE: A4 DRW NO.:  
 FINISH: SEE NOTES MAT'L.: SEE NOTES  
 SCALE: N/A REV.: A0 UNIT: mm PAGE: 1/1