

REV.	ECN NO	CONTENT	DATE	ENGINEER
A0		Initial release	/	SGF

SPECIFICATIONS

Current Rating: 1Amps
 Withstanding Voltage: AC 500V
 Insulation Resistance: 1000MΩ Min
 Contact Resistance: 20mΩ Max
 Operation Temperature: -40° to +105°
 Insulator Material: Polyester (UL94V-0)
 Contact Material: Phosphor bronze
 Standard: PA6T
 Contact Plating: Gold Flash
 Max. Processing Temp: 240° C for 30-60seconds
 (260° C for 5seconds)

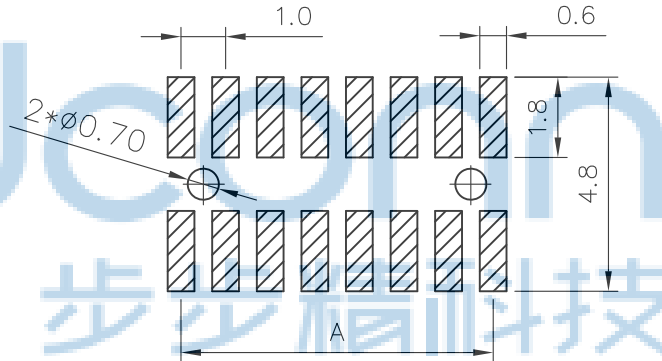
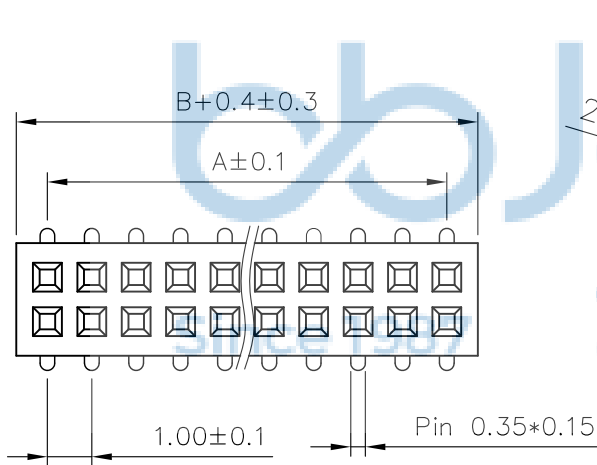
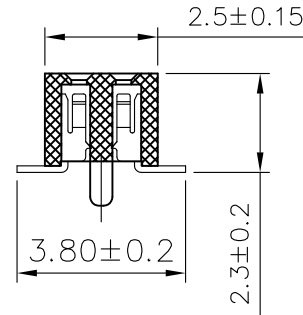
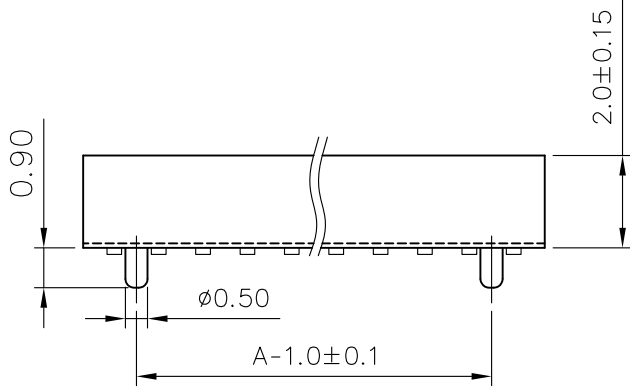

RECOMMEND P. C. B LAYOUT
 PCB TOLERANCE: ±0.05 (TOP VIEW)



No. of	DIM. A	DIM. B	No. of	DIM. A	DIM. B	No. of	DIM. A	DIM. B	No. of	DIM. A	DIM. B
1	0.00	1.00	11	10.00	11.00	21	20.00	21.00	31	30.00	31.00
2	1.00	2.00	12	11.00	12.00	22	21.00	22.00	32	31.00	32.00
3	2.00	3.00	13	12.00	13.00	23	22.00	23.00	33	32.00	33.00
4	3.00	4.00	14	13.00	14.00	24	23.00	24.00	34	33.00	34.00
5	4.00	5.00	15	14.00	15.00	25	24.00	25.00	35	34.00	35.00
6	5.00	6.00	16	15.00	16.00	26	25.00	26.00	36	35.00	36.00
7	6.00	7.00	17	16.00	17.00	27	26.00	27.00	37	36.00	37.00
8	7.00	8.00	18	17.00	18.00	28	27.00	28.00	38	37.00	38.00
9	8.00	9.00	19	18.00	19.00	29	28.00	29.00	39	38.00	39.00
10	9.00	10.00	20	19.00	20.00	30	29.00	30.00	40	39.00	40.00

THIS DOCUMENT IS THE SOLE PROPERTY OF BBJconn Technology Co., Ltd. Corporation AND SHOULD NOT BE USED IN WHOLE OR IN PART WITHOUT PRIOR WRITTEN PERMISSION.

PDWG. NO.: 0266-1

APPD. JM_Zheng
 CHKD. LYX
 DR. SGF

深圳市步步精科技有限公司

.X: ±0.38 .X': ±3"
 .XX: ±0.25 .X'': ±2"
 .XXX: ±0.13 .X''': ±1"

NAME: 排母 1.0FH H2.0 2x3P SMT U型 PC3.8 6T 带柱 贴膜编带

PJ. NO.: FH.02.22-13-3001
 SIZE: A4 DRW NO.:

FINISH: SEE NOTES MAT'L.: SEE NOTES
 SCALE: N/A REV.: A0 UNIT: mm PAGE: 1/2

REV.	ECN NO.	CONTENT	DATE	ENGINEER
A0		Initial release	/	SGF

W	24.00±0.3
F	11.50±0.1
T	0.40±0.05
E	1.75±0.1
P	12.00±0.1
P0	4±0.1
P2	2±0.1
A0	5.60±0.1
B0	2.94±0.1
K0	8.30±0.1
D0	1.50 ^{+0.10} ₋₀

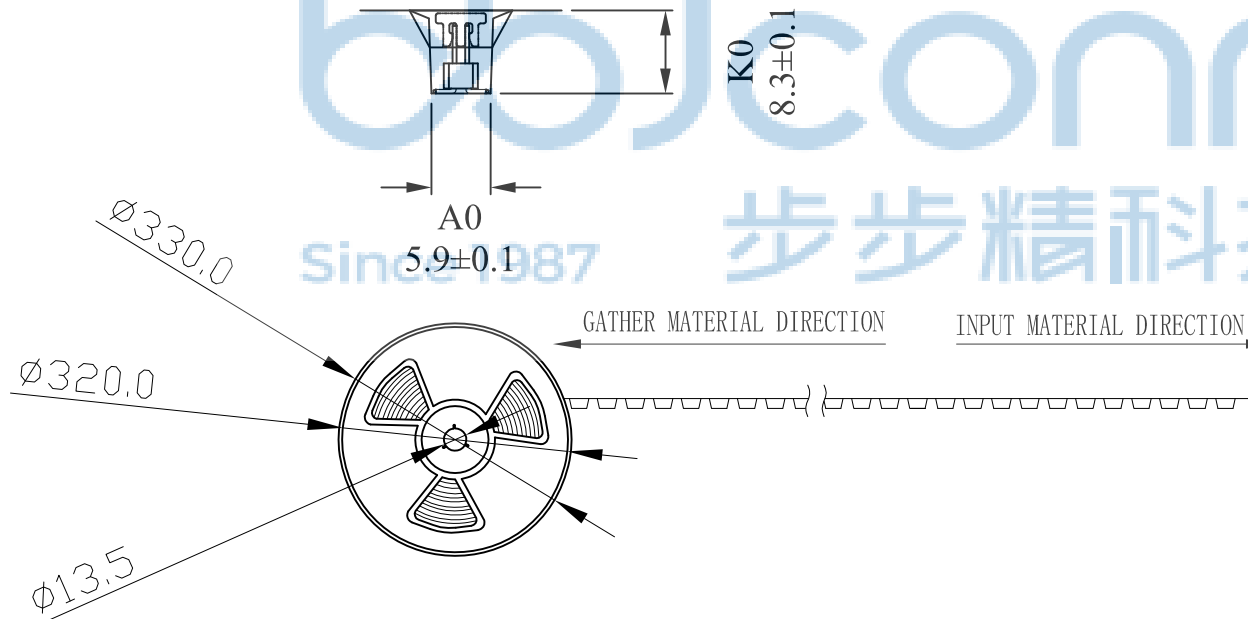
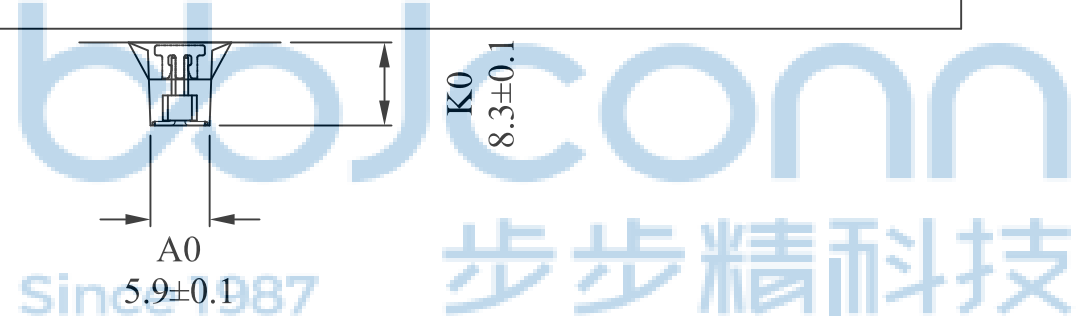
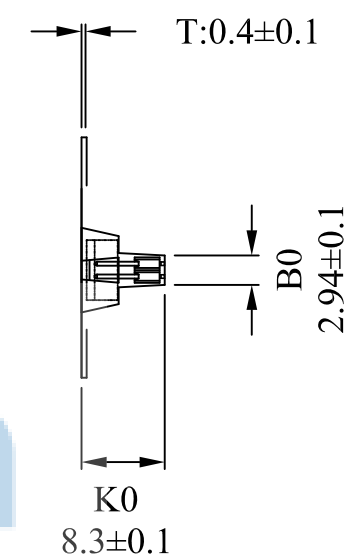
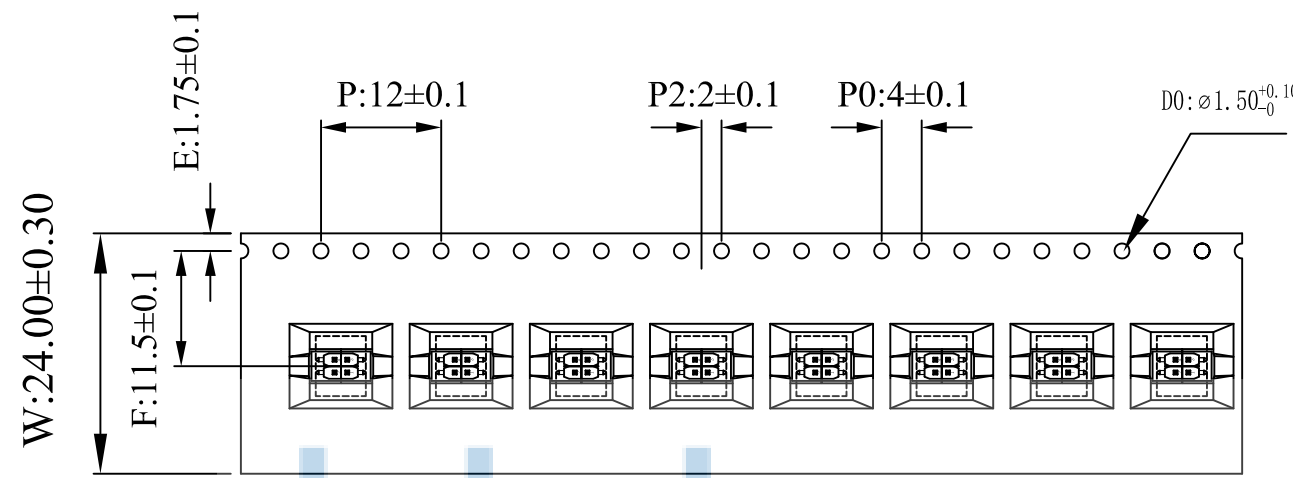

料号		载带宽度	W24	载带长度	7.68米
数量	800pcs/卷	装箱数量		卷盘外径	330mm/13寸
留空	20-600-20	上带规格	21.3mm*200米	冷封/热封	冷封
模具		下带颜色	雾透	下带材质	PS

THIS DOCUMENT IS THE SOLE PROPERTY OF BBJconn Technology Co.,Ltd. Corporation AND SHOULD NOT BE USED IN WHOLE OR IN PART WITHOUT PRIOR WRITTEN PERMISSION.

PDWG.NO: 0266-1

DR. SGF

APPD. JM_Zheng

CHKD. LYX

深 圳 市 步 步 精 科 技 有 限 公 司

NAME: 排母 1.0FH H2.0 2x3P SMT U型 PC3.8 6T 带柱 贴膜编带

PJ. NO.: FH.02.22-13-3001

SIZE: A4 | DRW NO.:

FINISH: SEE NOTES | MAT'L.: SEE NOTES

SCALE: N/A | REV.: A0 | UNIT: mm | PAGE: 2/2