

REV.	ECN NO	CONTENT	DATE	ENGINEER
A0		Initial release	/	SGF

### SPECIFICATIONS

Current Rating: 3Amps  
 Insulation Resistance: 1000MΩ Min  
 Contact Resistance: 20MΩ Max  
 Withstanding Voltage: AC 1000V  
 Operation Temperature: -40 ° to+105°  
 Contact Material: Brass  
 Standard: PA6T  
 Insulator Material: Polyester(UL 94V-0)  
 Contact Plating: Gold Flash  
 Max. Processing Temp: 200 ° C for30-60seconds  
 (220 ° C for5seconds)

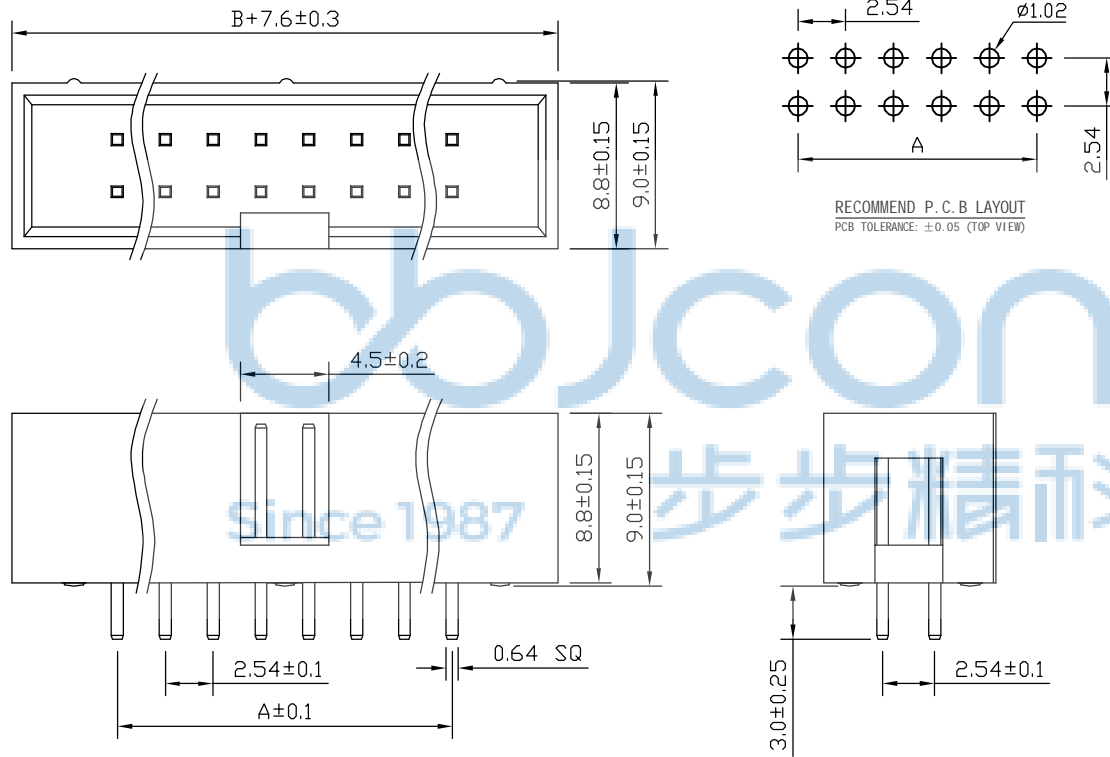

No. of	DIM. A	DIM. B	No. of	DIM. A	DIM. B	No. of	DIM. A	DIM. B
6	5.08	7.62	20	22.86	25.40	36	43.18	45.72
8	7.62	10.16	24	27.94	30.48	40	48.26	50.80
10	10.16	12.70	26	30.48	33.02	44	53.34	55.88
12	12.70	15.24	28	33.02	35.56	50	60.96	63.50
14	15.24	17.78	30	35.56	38.10	60	73.66	76.20
16	17.78	20.32	32	38.10	40.64	64	78.74	81.28
18	20.32	22.86	34	40.64	43.18			



THIS DOCUMENT IS THE SOLE PROPERTY OF BBJconn Technology Co.,Ltd. Corporation AND SHOULD NOT BE USED IN WHOLE OR IN PART WITHOUT PRIOR WRITTEN PERMISSION.

PDWG.NO: 0266-1

DR. SGF

APPD. JM\_Zheng

CHKD. LYX

NAME: 深圳市步步精科技有限公司  
 筒牛连接器 2.54DC3 (2x10)20P H8.9 180度 PC3.0 L11.5 6T 袋装

PJ. NO.: PH.08.12-21-6001

SIZE: A4 DRW NO.:

FINISH: SEE NOTES MAT'L.: SEE NOTES

SCALE: N/A REV.: A0 UNIT: mm PAGE: 1/2

REV.	ECN NO	CONTENT	DATE	ENGINEER
A0		Initial release	/	SGF

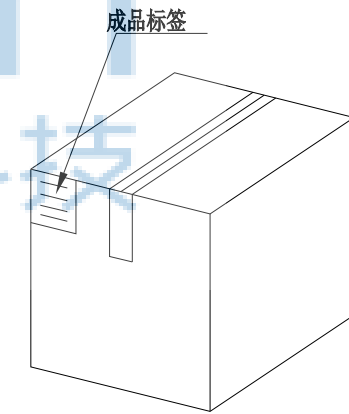
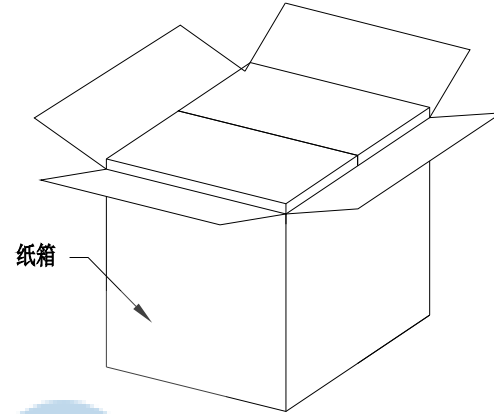
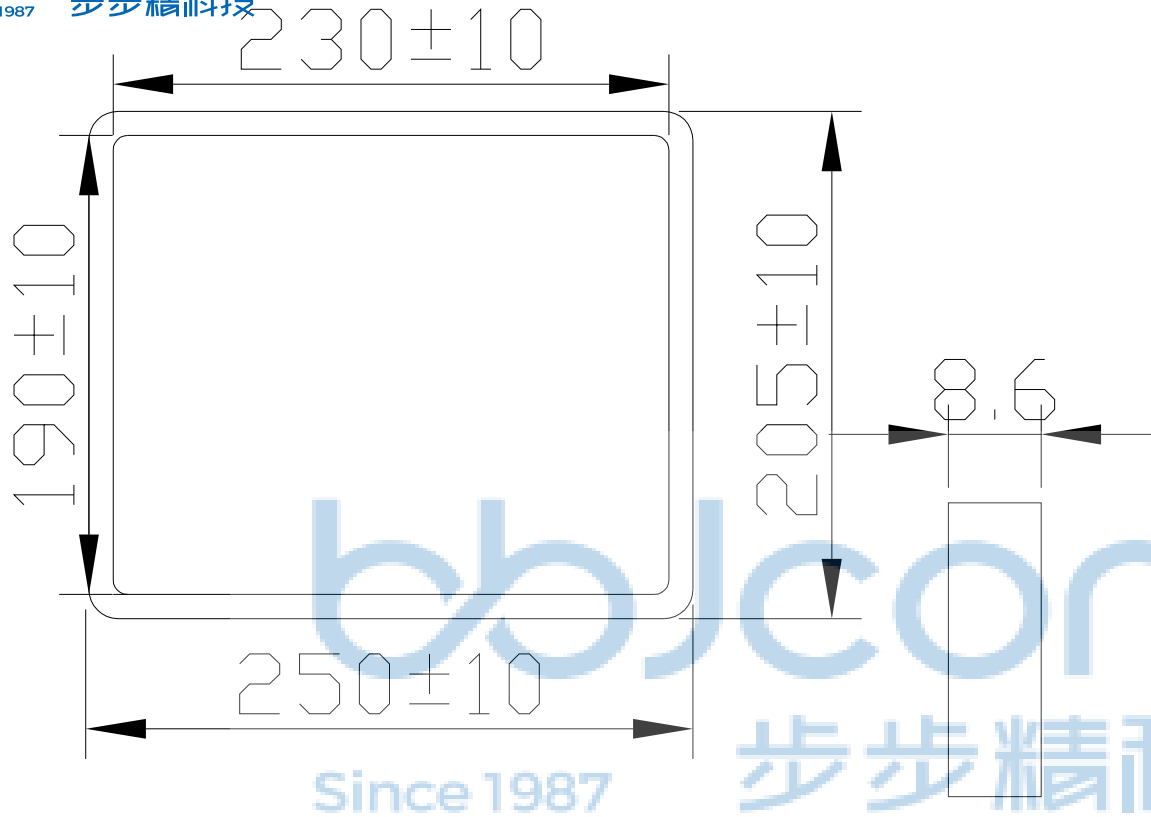

纸箱规格: 350\*210\*290

1. 包装要求:

- 1.1 每盒吸塑盒包装300 pcs;
- 1.2 每20盘放一箱, 共计6000PCS;
- 1.3 纸箱外贴上标签



THIS DOCUMENT IS THE SOLE PROPERTY OF BBJconn Technology Co.,Ltd. Corporation AND SHOULD NOT BE USED IN WHOLE OR IN PART WITHOUT PRIOR WRITTEN PERMISSION.		深圳市步步精科技有限公司 .X: ±0.38    .X': ±3" .XX: ±0.25    .X'': ±2" .XXX: ±0.13    .XX': ±1"		NAME: 筒牛连接器 2.54DC3 (2x10)20P H8.9 180度 PC3.0 L11.5 6T 袋装	
APPD.	JM_Zheng	PJ. NO.: PH.08.12-21-6001		SIZE: A4   DRW NO.:	
CHKD.	LYX	FINISH: SEE NOTES   MAT'L.: SEE NOTES		SCALE: N/A   REV.: A0   UNIT: mm   PAGE: 2/2	
PDWG.NO:	0266-1	DR.	SGF		