

REV.	ECN NO	CONTENT	DATE	ENGINEER
A0		Initial release	/	SGF

### SPECIFICATIONS

Current Rating: 1.5 Amps  
 Insulation Resistance: 1000MΩ, Min  
 Contact Resistance: 20mΩ, Max  
 Withstanding Voltage: AC 500V  
 Operation Temperature: -40° to +105°  
 Contact Material: Brass  
 Standard: PA6T  
 Insulator Material: Polyester (UL 94V-0)  
 Contact Plating: Gold Flash  
 Max. Processing Temp: 240° C for 30-60 seconds  
 (260° C for 5 seconds)

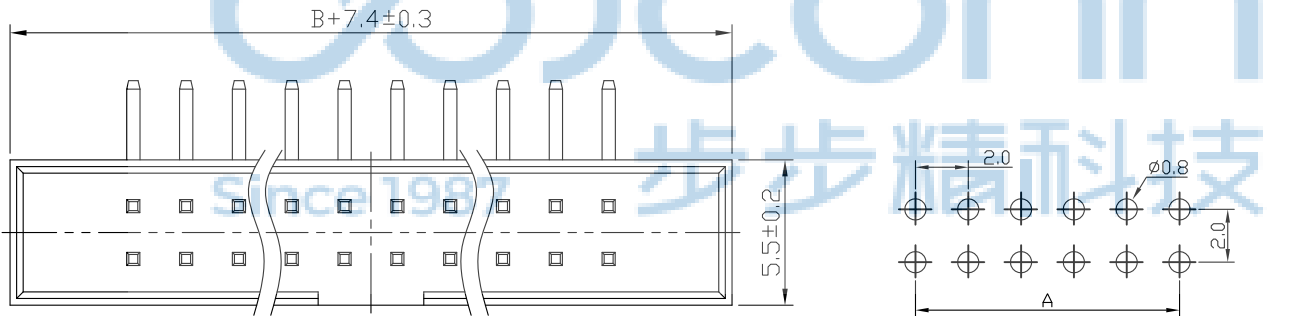
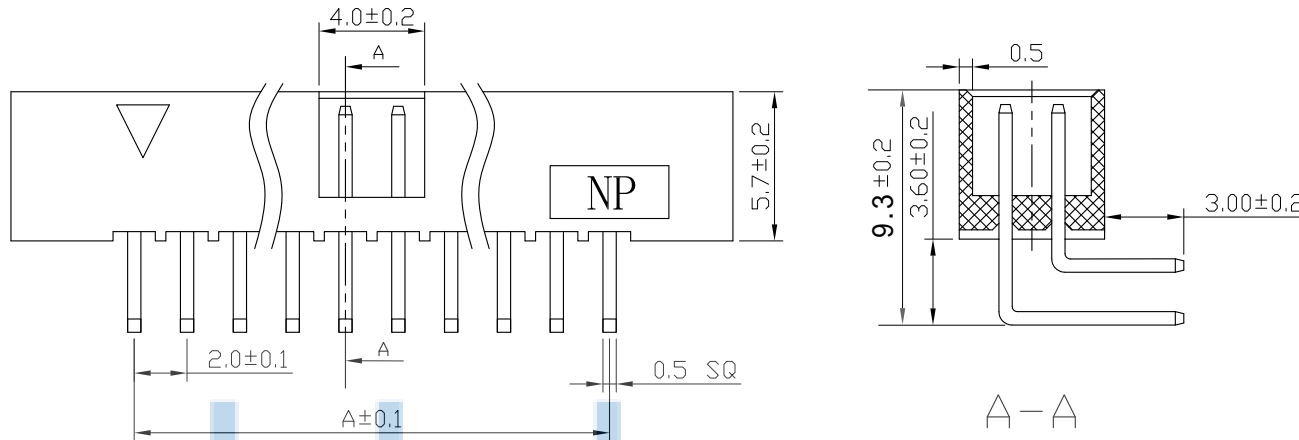

No. of	DIM. A	DIM. B	No. of	DIM. A	DIM. B	No. of	DIM. A	DIM. B
6	4.00	6.00	20	18.00	20.00	36	34.00	36.00
8	6.00	8.00	24	22.00	24.00	40	38.00	40.00
10	8.00	10.00	26	24.00	26.00	44	42.00	44.00
12	10.00	12.00	30	28.00	30.00			
14	12.00	14.00	34	32.00	34.00			
16	14.00	16.00	36	34.00	36.00			
18	16.00	18.00	40	38.00	40.00			



THIS DOCUMENT IS THE SOLE PROPERTY OF BBJconn Technology Co., Ltd. CORPORATION AND SHOULD NOT BE USED IN WHOLE OR IN PART WITHOUT PRIOR WRITTEN PERMISSION.

PDWG. NO: 0266-1

APPD. JM\_Zheng  
CHKD. LYX  
DR. SGF

NAME: 筒牛连接器 2.0DC3 30P H5.7 90度 PC3.0 PB9.3 L11-15 6T

PJ. NO.: FH.08.12-82-3001  
SIZE: A4 DRW NO.:  
FINISH: SEE NOTES MAT'L.: SEE NOTES  
SCALE: N/A REV.: A0 UNIT: mm PAGE: 1/2

**深圳市步步精科技有限公司**

REV.	ECN NO	CONTENT	DATE	ENGINEER
A0		Initial release	/	SGF

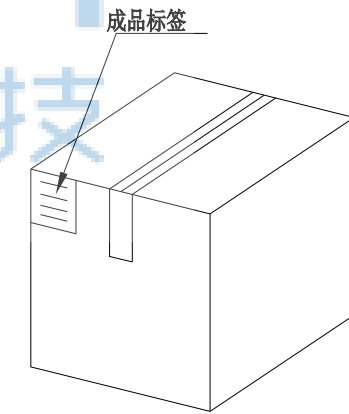
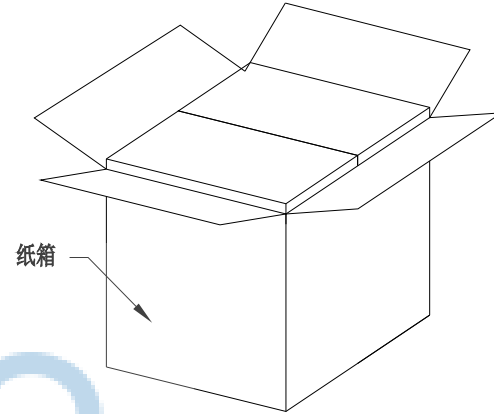
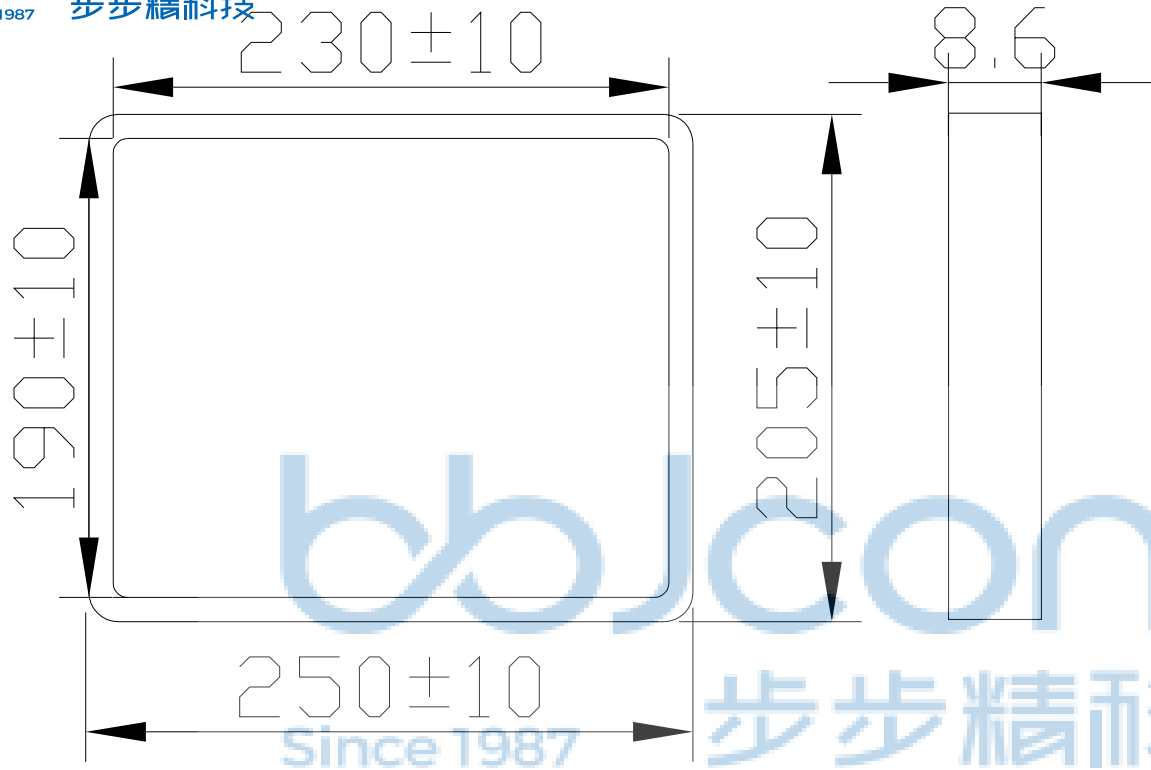

1. 包装要求:
- 1.1 每盒吸塑盒包装 2000 pcs;
  - 1.2 每20盘放一箱, 共计40000 PCS;
  - 1.3 纸箱外贴上标签



纸箱规格: 350\*210\*290

THIS DOCUMENT IS THE SOLE PROPERTY OF BBJconn Technology Co.,Ltd. Corporation AND SHOULD NOT BE USED IN WHOLE OR IN PART WITHOUT PRIOR WRITTEN PERMISSION.		深圳市步步精科技有限公司 .X: ±0.38 .X': ±3" .XX: ±0.25 .X": ±2" .XXX: ±0.13 .XX': ±1"		NAME: 筒牛连接器 2.0DC3 30P H5.7 90度 PC3.0 PB9.3 L11-15 6T PJ. NO.: FH.08.12-82-3001 SIZE: A4 DRW NO.: FINISH: SEE NOTES MAT'L.: SEE NOTES SCALE: N/A REV.: A0 UNIT: mm PAGE: 2/2	
APPD.	JM_Zheng	CHKD.	LYX	DR.	SGF
PDWG.NO: 0266-1					