

Rating	3-5 A 125/250VAC	Mechanical Life	300,000 cycles
Contact Resistance	500mΩ Max	Electrical Life	10,000 cycles
Insulation Resistance	>100MΩ DC500V	Ambient Temper. Used	-25℃ to +105℃
Withstand Voltage	AC1500V 1min.	Ambient Humidity Used	≤85% at +40℃
Soldering Temper.	235±5℃ 5s	Operating Force	50 ±20gf max

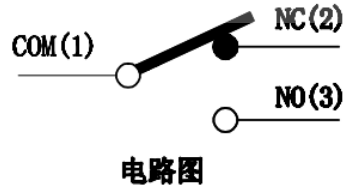

10	压柄	1	SUS301	
9	触点	3	紫铜点	
8	弹簧	1	SUS304	
7	弹片	1	紫铜	
6	NO端子	1	C2680	
5	NC端子	1	C2680	
4	COM端子	1	C2680	
3	按钮	1	FBT	UL94V-0
2	下盖	1	FBT	UL94V-0
1	上盖	1	FBT	UL94V-0
序号	零件名称	数量	材质	备注

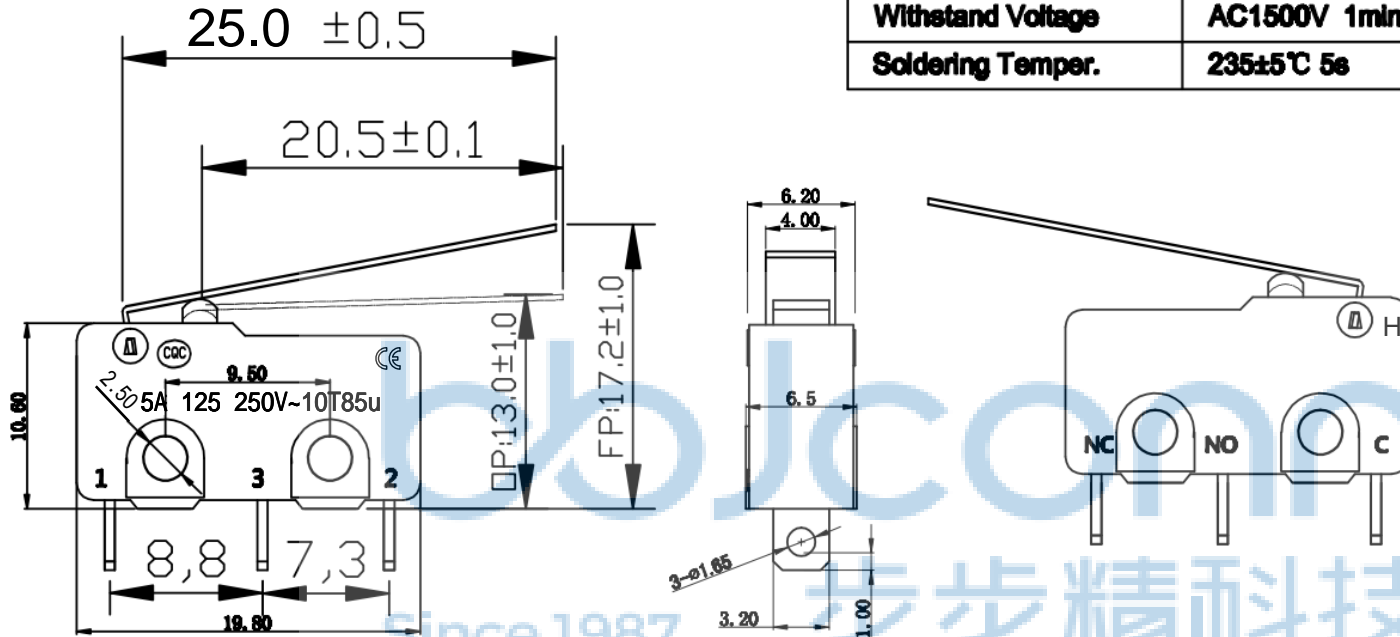

THIS DOCUMENT IS THE SOLE PROPERTY OF BBJconn Technology Co., Ltd. Corporation AND SHOULD NOT BE USED IN WHOLE OR IN PART WITHOUT PRIOR WRITTEN PERMISSION.
PDWG.NO: 0230-1

深圳市步步精科技有限公司

NAME: 微动开关 中微动 带柄 三脚插

PJ. NO.: WK.02.02-35-0004
SIZE: A4 DRW NO.:

FINISH: SEE NOTES MAT'L.: SEE NOTES
SCALE: N/A REV.: A0 UNIT: mm PAGE: 1/2

APPD. JM_Zheng
CHKD. LYX
DR. SGF

REV.	ECN NO	CONTENT	DATE	ENGINEER
A0		Initial release	/	SGF

PE袋规格:***X*** (以实际出货为准)

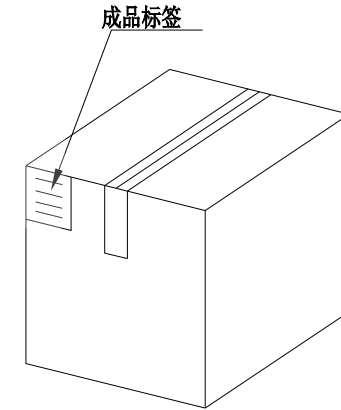
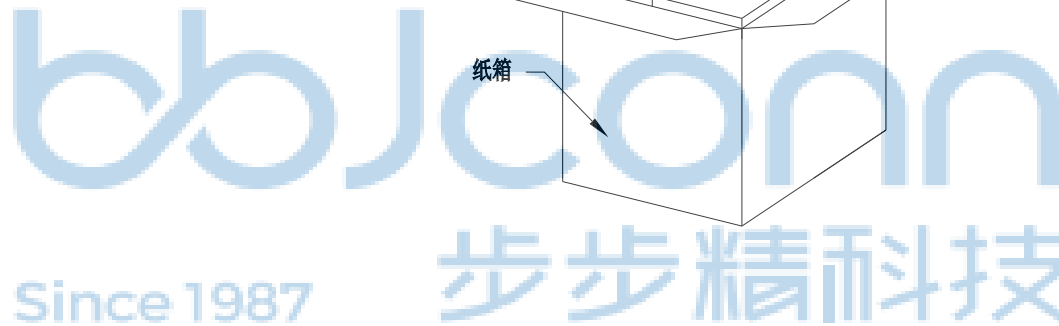
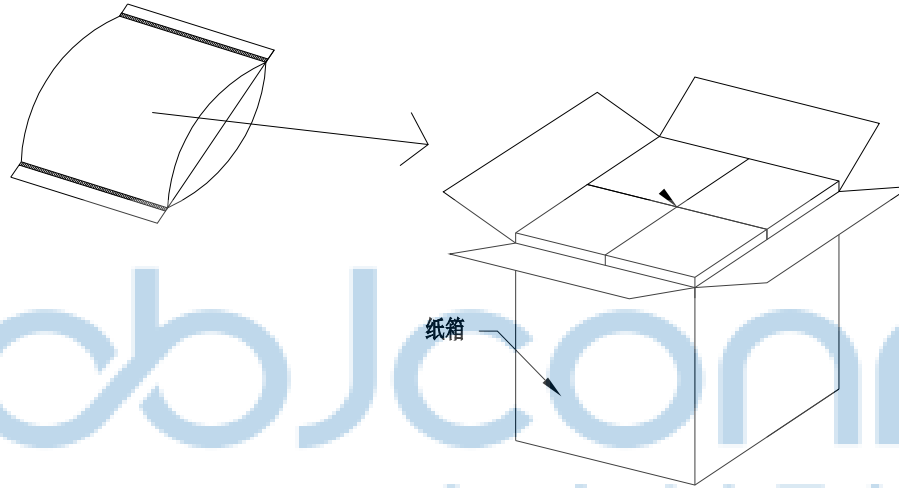

1. 包装要求:

- 1.1 每PE袋包装500 PCS;
- 1.2 每1袋放一小纸盒;
- 1.3 每20个小纸盒放一个纸箱, 共计10000PCS
- 1.4 纸箱外贴上标签



THIS DOCUMENT IS THE SOLE PROPERTY OF BBJconn Technology Co.,Ltd. Corporation AND SHOULD NOT BE USED IN WHOLE OR IN PART WITHOUT PRIOR WRITTEN PERMISSION.		深圳市步步精科技有限公司 .X: ±0.38 X': ±3' NAME: 微动开关 中微动 带柄 三脚插 .XX: ±0.25 .X': ±2' .XXX: ±0.13 .XX': ±1'	
PDWG.NO: 0230-1	DR. SGF	APPD. JM_Zheng	PJ. NO.: WK.02.02-35-0004 SIZE: A4 DRW NO.: FINISH: SEE NOTES MAT'L.: SEE NOTES SCALE: N/A REV.: A0 UNIT: mm PAGE: 2/2