

Since 1987

步步精科技



Rating	5 A 125/250VAC	Mechanical Life	500,000 cycles
Contact Resistance	500mΩ Max	Electrical Life	UL10,000 cycles TUV50,000 cycles
Insulation Resistance	>100MΩ DC500V	Ambient Temper. Used	-25℃ to +125℃
Withstand Voltage	AC1500V 1min.	Ambient Humidity Used	≤85% at +40℃
Soldering Temper.	235±5℃ 5s	Operating Force	40 ±20gf max

10	压柄	1	SUS301	
9	触点	3	银合金	
8	C弹片	1	C17200	
7	弹片	1	C5210	
6	NO端子	1	C2680	
5	NC端子	1	C2680	
4	COM端子	1	C2680	
3	按钮	1	PBT	UL94V-0
2	下盖	1	PBT	UL94V-0
1	上盖	1	PBT	UL94V-0
序号	零件名称	数量	材质	备注

THIS DOCUMENT IS THE SOLE PROPERTY OF BBJconn Technology Co., Ltd. Corporation AND SHOULD NOT BE USED IN WHOLE OR IN PART WITHOUT PRIOR WRITTEN PERMISSION.

PDWG.NO: 0230-1 DR. SGF

APPD. JM_Zheng

CHKD. LYX

NAME: 微动开关 中微动 直柄 3直脚 耐高温235度

PJ. NO.: WK.02.02-35-0002

SIZE: A4 | DRW NO.:

FINISH: SEE NOTES | MAT'L.: SEE NOTES

SCALE: N/A | REV.: A0 | UNIT: mm | PAGE: 1/2

深圳市步步精科技有限公司

REV.	ECN NO	CONTENT	DATE	ENGINEER
A0		Initial release	/	SGF

PE袋规格: 260*185

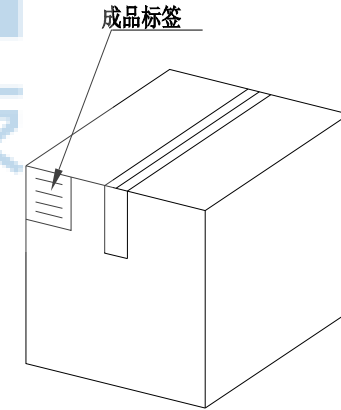
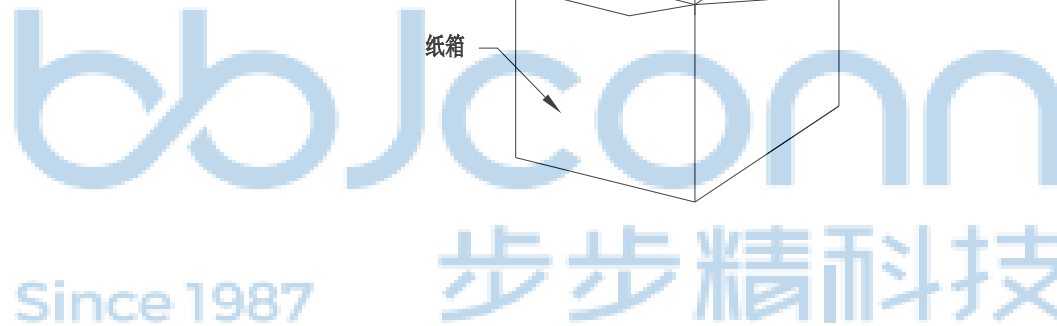
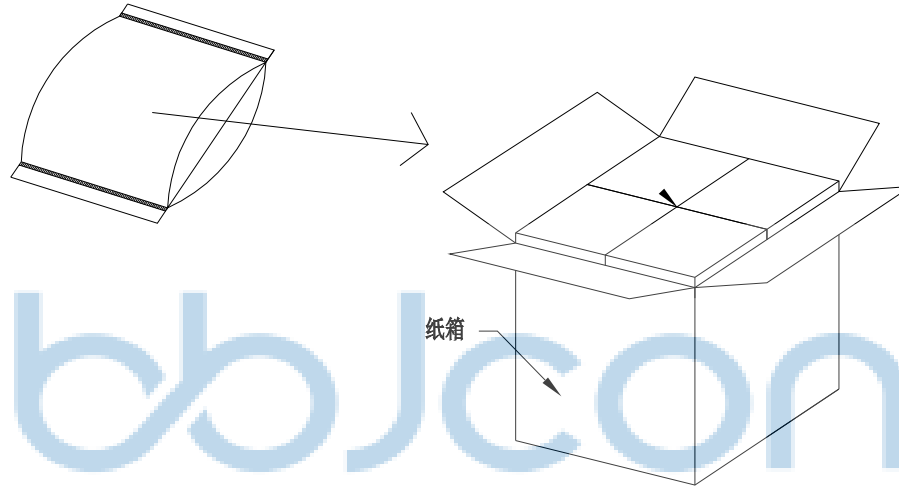

1. 包装要求:

- 1.1 每PE袋包装500 pcs;
- 1.2 每1袋放一小纸盒;
- 1.3 每20个小纸盒放一个纸箱, 共计10000 PCS
- 1.4 纸箱外贴上标签



THIS DOCUMENT IS THE SOLE PROPERTY OF BBJconn Technology Co.,Ltd. Corporation AND SHOULD NOT BE USED IN WHOLE OR IN PART WITHOUT PRIOR WRITTEN PERMISSION.		深圳市步步精科技有限公司 .X: ±0.38 X*: ±3* .XX: ±0.25 .X*: ±2* .XXX: ±0.13 .XX*: ±1*	
APPD.	JM_Zheng	NAME: 微动开关 中微动 直柄 3直脚 耐高温235度	
CHKD.	LYX	PJ. NO.: WK.02.02-35-0002	
DR.	SGF	SIZE: A4 DRW NO.:	
PDWG.NO: 0230-1		FINISH: SEE NOTES MAT'L.: SEE NOTES	
		SCALE: N/A REV.: A0 UNIT: mm PAGE: 2/2	