

REV.	ECN NO	CONTENT	DATE	ENGINEER
A0		Initial release	/	TSP

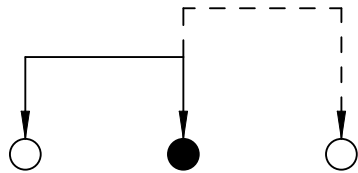
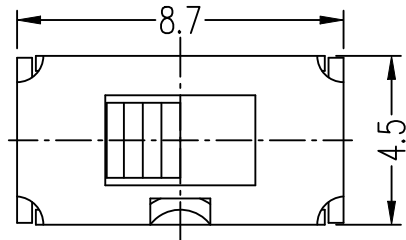

SCHEMATIC (NON-SHORTING)

额定值: 0.3A 50VDC  
 接触电阻: 100m max  
 绝缘电阻: 100M MIN  
 耐电压: AC 500V  
 寿命: 10000  
 工作温度: -25 +85

注: “\*”表示关键尺寸 (5个)

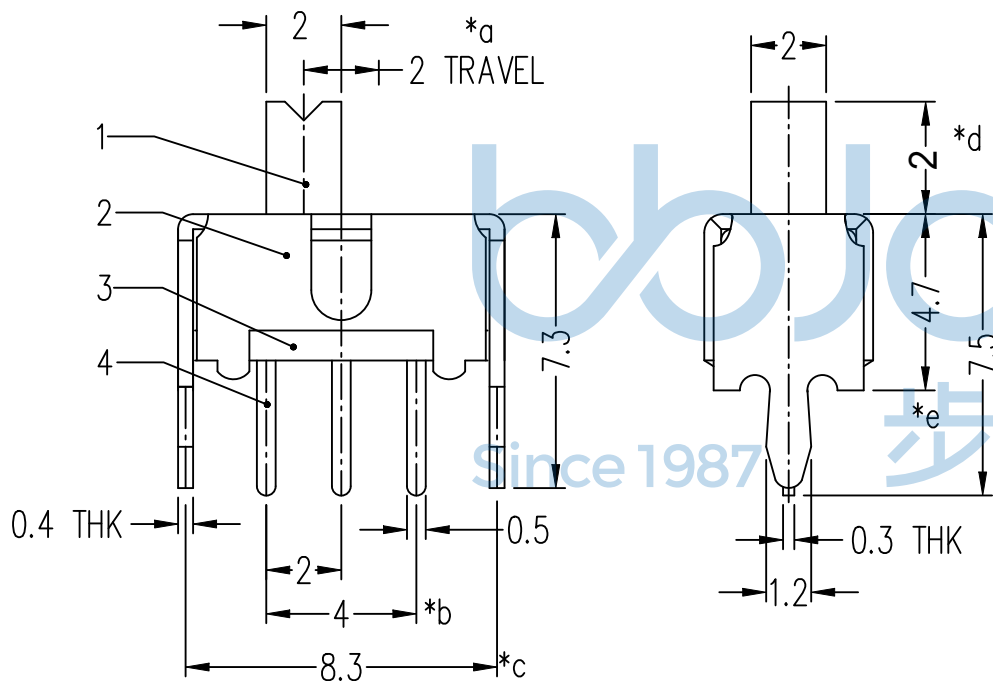
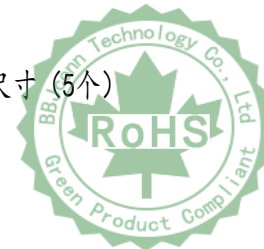

P.C.B LAYOUT  
BOTTOM VIEW

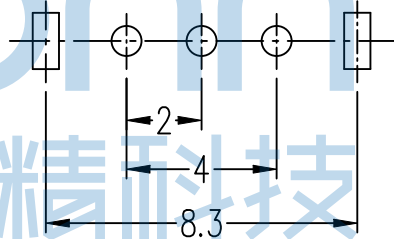

8				
7				
6				
5	CONTACT CLIP	PBS STRIP	1	Ag CLAD
4	TERMINAL	BRASS STRIP	3	Ag PLATED
3	BASE	PHENOLIC RESIN	1	NATURAL
2	FRAME	STEEL STRIP	1	Ni PLATED
1	KNOB	PA66	1	BLACK
NO.	PARTS	MATERIALS	Q'TY	FINISH

THIS DOCUMENT IS THE SOLE PROPERTY OF BBJconn Technology Co.,Ltd. Corporation AND SHOULD NOT BE USED IN WHOLE OR IN PART WITHOUT PRIOR WRITTEN PERMISSION.

**深圳市步步精科技有限公司**

NAME: 拨动开关 SS12D07VG2 高温金码 三脚直插 间距2.0 袋装

APPD. JM\_Zheng

CHKD. LYX

DR. TSP

PJ. NO.: SS.02.02-02-1001

SIZE: A4 DRW NO.:

FINISH: SEE NOTES MAT'L.: SEE NOTES

SCALE: N/A REV.: A0 UNIT: mm PAGE: 1/2

尺寸公差: .X: ±0.38 .XX: ±0.25 .XXX: ±0.13 X': ±3' X'': ±2' XX': ±1'

PDWG.NO: 0101-1

REV.	ECN NO	CONTENT	DATE	ENGINEER
A0		Initial release	/	TSP

PE袋规格: 260\*185

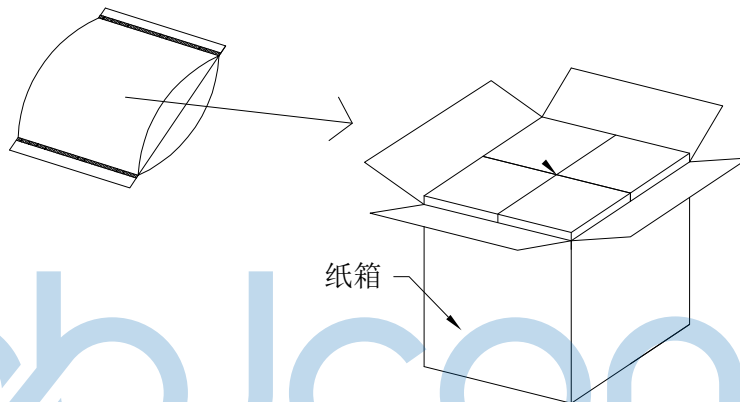

成品标签

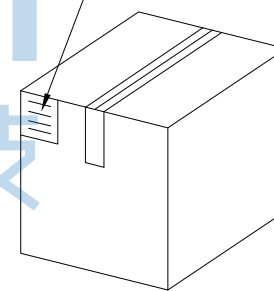

1. 包装要求:

- 1.1 每个PE袋包装1000pcs;
- 1.2 每1袋放一小纸盒;
- 1.3 每20个小纸盒放一个纸箱, 共计20000pcs;
- 1.4 纸箱外贴上标签



THIS DOCUMENT IS THE SOLE PROPERTY OF BBJconn Technology Co.,Ltd.		深圳市步步精科技有限公司	
Corporation AND SHOULD NOT BE USED IN WHOLE OR IN PART WITHOUT PRIOR WRITTEN PERMISSION.		NAME: 拨动开关 SS12D07VG2 高温金码 三脚直插 间距2.0 袋装	
APPD.	JM_Zheng	FINISH: SEE NOTES	MAT'L.: SEE NOTES
CHKD.	LYX	SCALE: N/A	REV.: A0
PDWG.NO:	0101-1	DR.	TSP
		PJ. NO.:	SS.02.02-02-1001
		SIZE:	A4
		DRW NO.:	
		UNIT:	mm
		PAGE:	2/2