

REV.	ECN NO.	CONTENT	DATE	ENGINEER
AO		Initial Release	/	LHC

额定值：3A 125V AC
 接触电阻：100毫欧以下
 绝缘电阻：1000兆欧以上
 耐电压：AC 1000V
 工作温度：-25 +85
 注：“*”表示关键尺寸(4个)

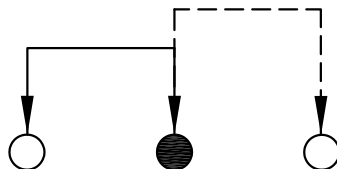

SCHMATIC (NON-SHORTING)

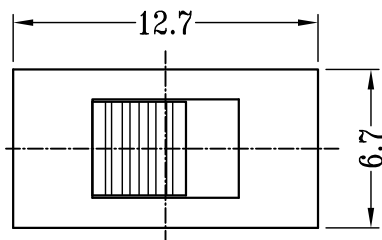
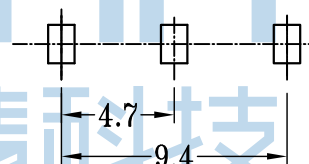
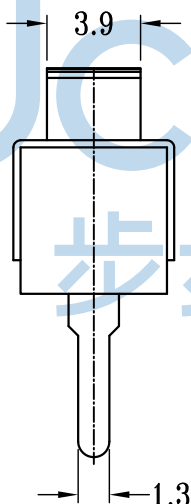
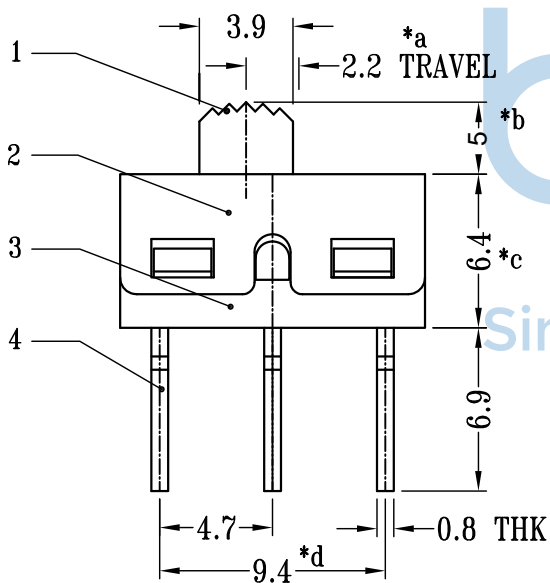

**P.C.B LAYOUT
BOTTOM VIEW**



NO.	PARTS	MATERIALS	Q'TY	FINISH
8				
7	STEEL BALL	STEEL	1	NATURAL
6	SPRING	STEEL WIRE	1	NATURAL
5	CONTACT	BRASS STRIP	1	Ag PLATED
4	TERMINAL	BRASS STRIP	3	Ag PLATED
3	CASE	PA66	1	BLACK
2	COVER	SUS	1	NATURAL
1	KNOB	POM	1	BLACK

THIS DOCUMENT IS THE SOLE PROPERTY OF BBJconn Technology Co., Ltd. Corporation AND SHOULD NOT BE USED IN WHOLE OR IN PART WITHOUT PRIOR WRITTEN PERMISSION.		深圳市步步精科技有限公司 NAME: 拨动开关 SS12D10G5 三脚插	
PDWG.NO: 0101-1	DR. LHC	APPD. JM_Zheng CHKD. LYX	PJ. NO.: SS.02.01-06-1002 SIZE: A4 DRW NO.: FINISH: SEE NOTES MAT'L.: SEE NOTES SCALE: N/A REV.: AO UNIT: mm PAGE: 1/2

REV.	ECN NO	CONTENT	DATE	ENGINEER
A0		Initial Release	/	LHC

PE袋规格: 260*185

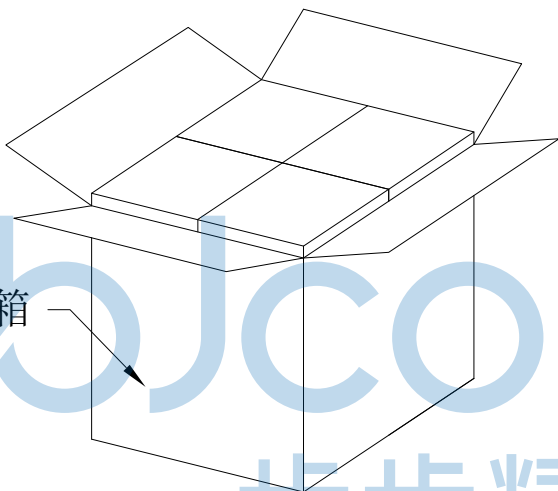
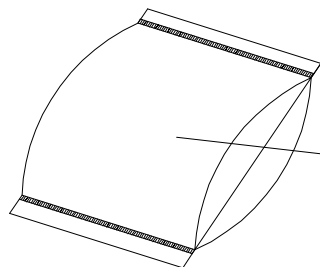

纸箱



成品标签

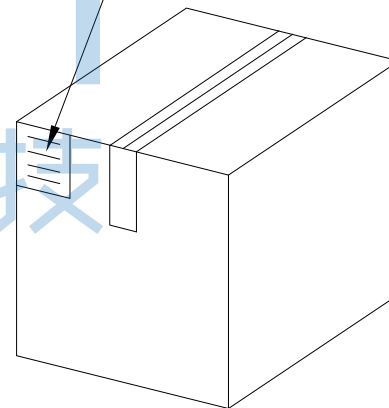

1. 包装要求:

- 1.1 每个PE袋包装 1000 pcs ;
- 1.2 每1袋放一小纸盒;
- 1.3 每20个小纸盒放一个纸箱, 共计 20000 pcs ;
- 1.4 纸箱外贴上标签



THIS DOCUMENT IS THE SOLE PROPERTY OF BBJconn Technology Co.,Ltd. Corporation AND SHOULD NOT BE USED IN WHOLE OR IN PART WITHOUT PRIOR WRITTEN PERMISSION.		深圳市步步精科技有限公司 .X: ±0.38 .X': ±3" .XX: ±0.25 .X': ±2" .XXX: ±0.13 .XX': ±1"		NAME: 拨动开关 SS12D10G5 三脚插	
APPD.	JM_Zheng	PJ. NO.: SS.02.01-06-1002 SIZE: A4 DRW NO.:		FINISH: SEE NOTES MAT'L.: SEE NOTES	
CHKD.	LYX	SCALE: N/A		REV.: A0	UNIT: mm
PDWG.NO:	0101-1	DR.	LHC	PAGE: 2/2	