

REV.	ECN NO	CONTENT	DATE	ENGINEER
A0				

NOTE

最大额定值 DC 12V 50mA
 接触电阻 100mΩ 以下
 绝缘电阻 100MΩ 以上
 电气耐压 AC 250 V
 行程 0.25 ± 0.10 mm
 使用温度范围 -20 to +70℃

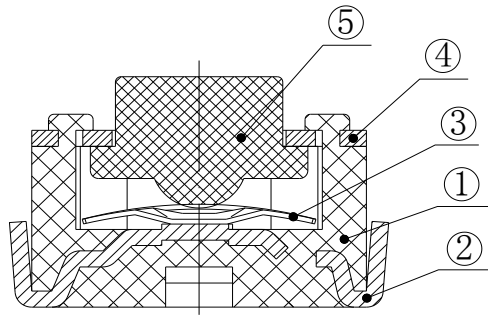
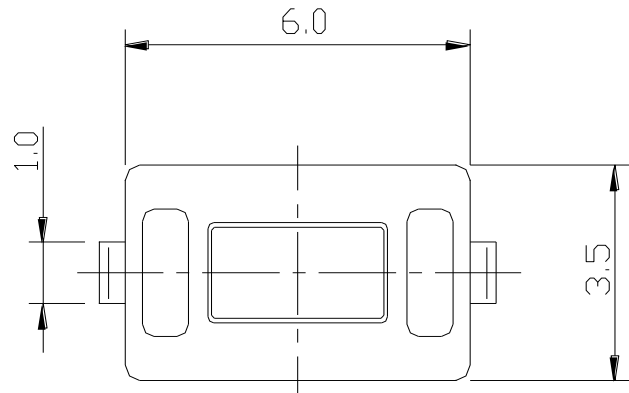

	4.3mm	BLACK	BLACK	250±50gf	30,000 Cycles
CODE NO.	"H"	STEM COLOR	CASE COLOR	O/FORCE	LIFE

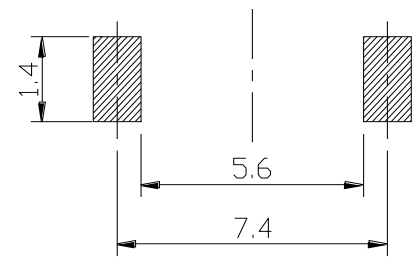
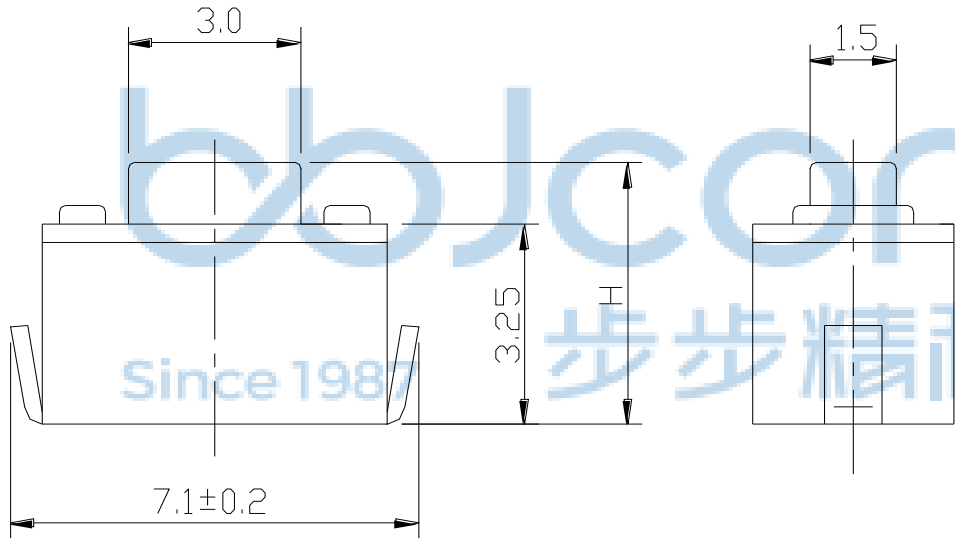

P.C.B LAND DIMENSION

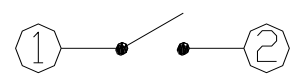

CIRCUIT DIAGRAM

序号	零部件名称	数量	材料名称	表面处理	备注
1	BASE	1	PA6T		Black
2	TERMINAL	1	BRASS	Ag plating	
3	CONTACT	2	STAINLESS STEEL	Ag plating	
4	COVER	1	COLD ROLLED STEEL	CuSn plating	
5	STEM	1	PA6T		Black

THIS DOCUMENT IS THE SOLE PROPERTY OF BBJconn Technology Co., Ltd. Corporation AND SHOULD NOT BE USED IN WHOLE OR IN PART WITHOUT PRIOR WRITTEN PERMISSION.

PDWG.NO: 0278-1

深圳市步步精科技有限公司

NAME: 轻触开关 3x6x4.3 U型脚 两脚贴片 不锈钢弹片 260gf 全黑

APPD. JM_Zheng

CHKD. LYX

DR. LHC

PJ. NO.: TS.35.10-11-38-01

SIZE: A4 | DRW NO.:

FINISH: SEE NOTES | MAT'L.: SEE NOTES

SCALE: N/A | REV.: A0 | UNIT: mm | PAGE: 1/2

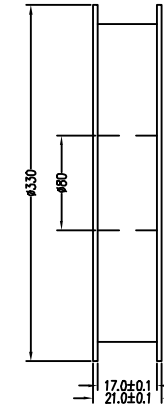
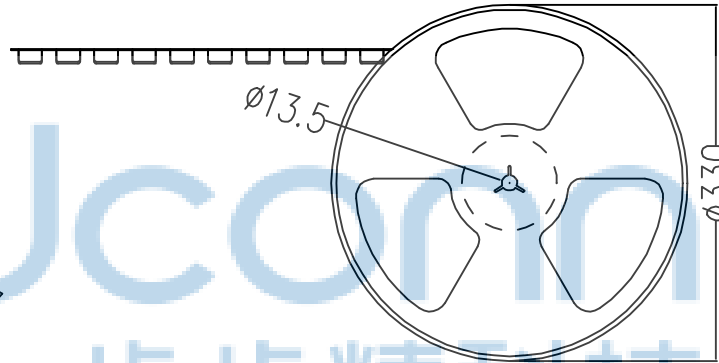
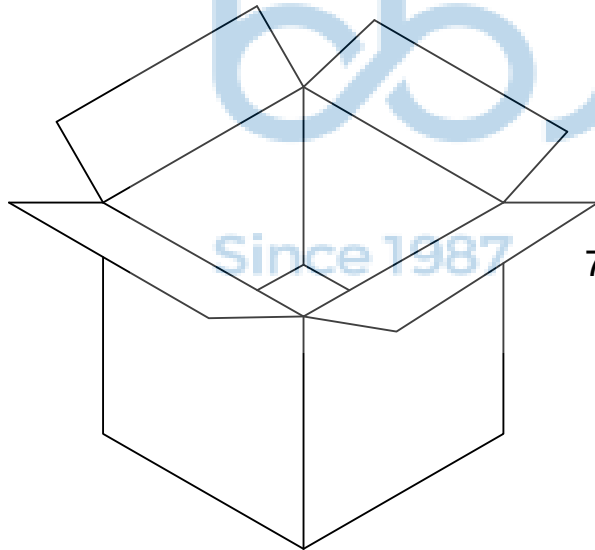
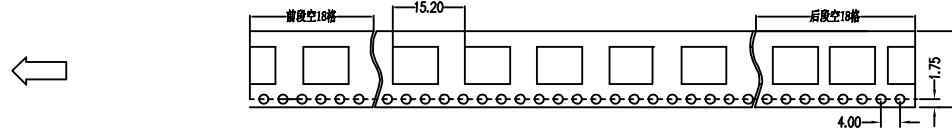
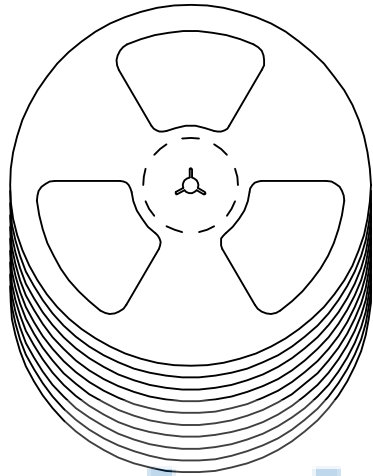

7# Ö
 5>ö Gy Ö 1500 3 & 6 § È § 1á Ä
 5>ö>»K Ö Ö!y § } > 40ª Z0ª I È]L\$ 5>ö Ä
 €CX Ö
 E- f Ö6Š I' Ä 3 6 Å ÈLk Ç
 : V Ö6Š %' Ä 3 (7 Å Lk Ç
 §- Ö6Š9 %' Ä

4è1á?ô I Ö 00
 4è1á?ô I Ö 00

THIS DOCUMENT IS THE SOLE PROPERTY OF BBJconn Technology Co.,Ltd. Corporation AND SHOULD NOT BE USED IN WHOLE OR IN PART WITHOUT PRIOR WRITTEN PERMISSION.		\$! c 2!•!•2!0 ° 9L€ œ (
.X: ±0.38 .XX: ±0.25 .XXX: ±0.13 X': ±3" X": ±2" XX': ±1"		NAME: Çá'¥çª¹Ø 3x6x4.3 UDi½Ä Á½½ÄiüÆ-²»Đä,ÖµÆ- 260gf Èª¼Ü	
APPD. JM_Zheng	PJ. NO.: TS.35.10-11-38-01		SIZE: A4 DRW NO.:
CHKD. LYX	FINISH: SEE NOTES		MAT'L.: SEE NOTES
PDWG.NO: 0278-1	DR. LHC	SCALE: N/A	REV.: AO UNIT: mm PAGE: 2/2