

REV.	ECN NO	CONTENT	DATE	ENGINEER
A0		Initial release	/	TSP

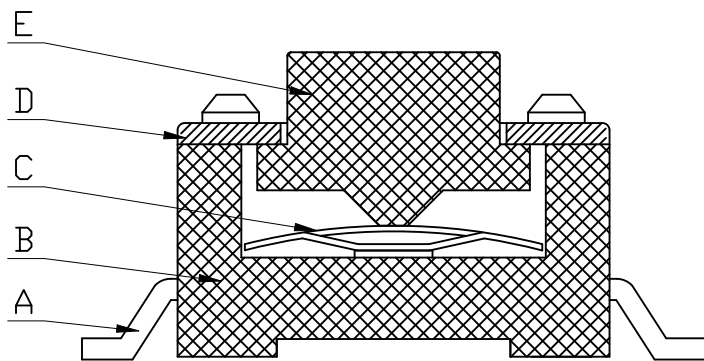

- 技术要求:
1. 零部件表面光洁无划伤, 水花, 变形, 影响外观及性能等缺陷。
 2. 额定电流: 50mA. 12V DC, 绝缘电阻100MΩ min, 100V DC, 介电强度250V AC for 1min, 接触电阻 100mΩ max。260° 高温后衰变值在初始值的 20%内;
 3. 开关手感明显, 档位清晰可靠, 无卡滞现象, 消除外力后, 应能快速回位。
 4. 带*尺寸为重点控制对象, 序号标记尺寸为记录尺寸。

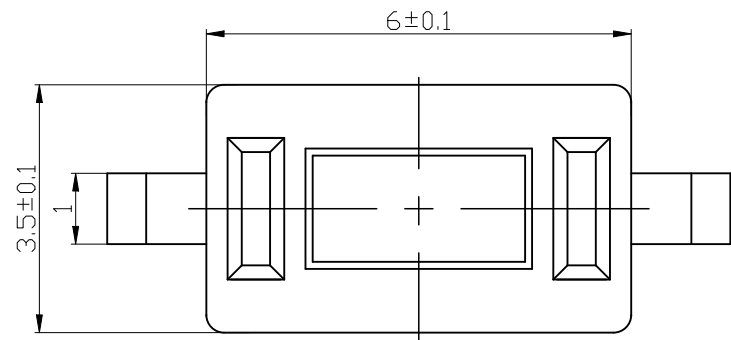
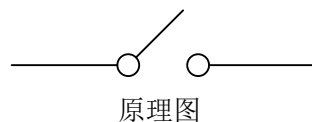
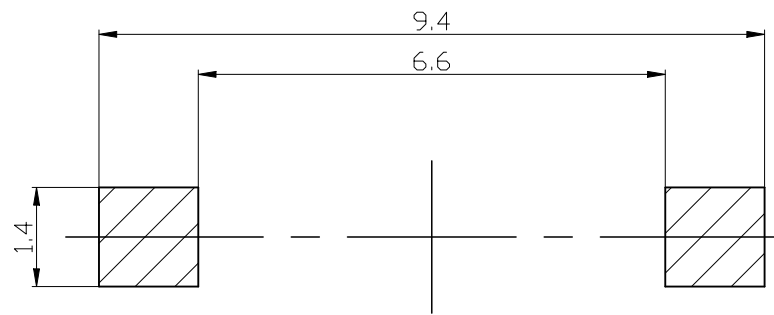
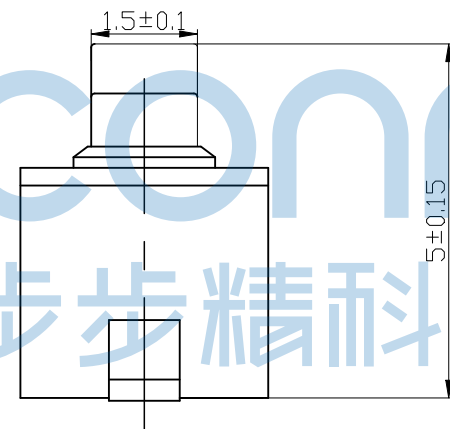
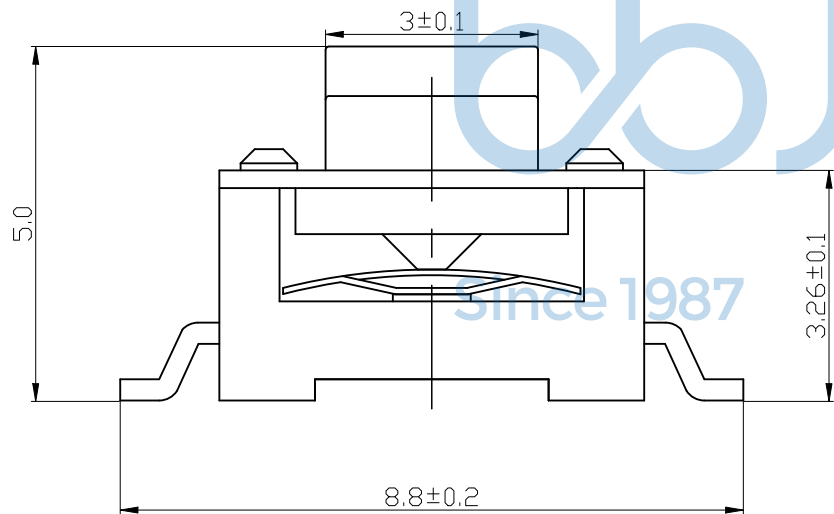

安装参考图

序号	名称	材料	数量	备注
E	盖板	铁0.25	1	镀铜锡
D	按钮	PPA白	1	
C	簧片	进口不锈钢覆银	1	
B	底座	PPA白	1	
A	卡件	黄铜厚0.3	1	镀银

THIS DOCUMENT IS THE SOLE PROPERTY OF BBJconn Technology Co.,Ltd. Corporation AND SHOULD NOT BE USED IN WHOLE OR IN PART WITHOUT PRIOR WRITTEN PERMISSION.

PDWG:NO: 0278-1

APPD. JM_Zheng

CHKD. LYX

DR. TSP

深圳市步步精科技有限公司

NAME: 轻触开关 3x6x5 两脚贴片 方头 无柱 不锈钢弹片 260GF 全白 热封编带

PJ. NO.: TS.10.13-11-38-22

SIZE: A4 | DRW NO.:

FINISH: SEE NOTES | MAT'L.: SEE NOTES

SCALE: N/A | REV.: A0 | UNIT: mm | PAGE: 1/2

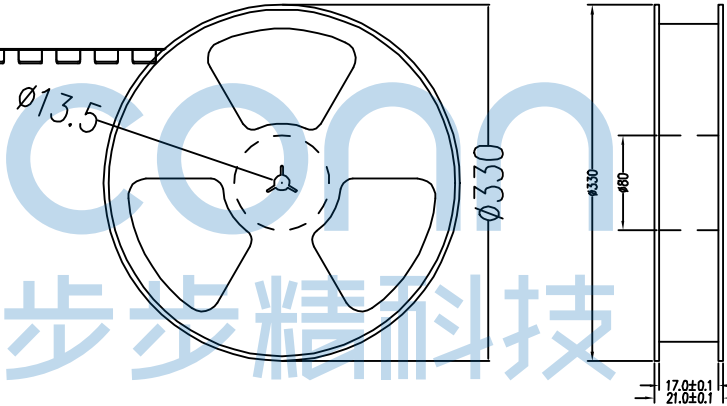
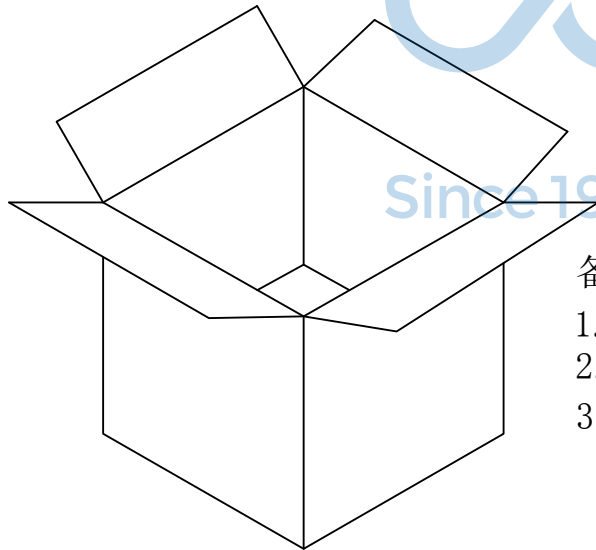
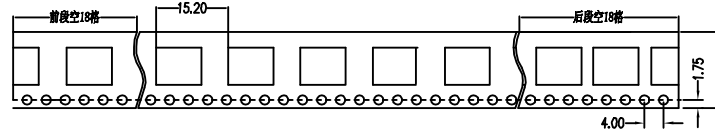
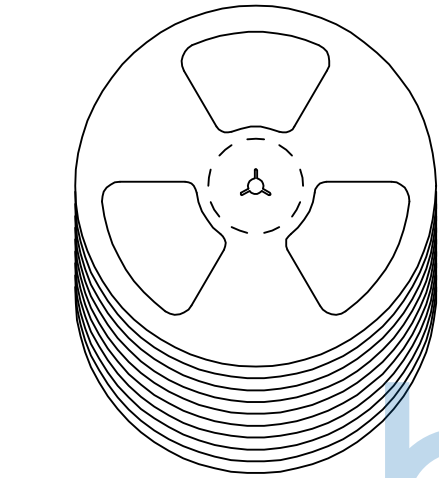

备注:

1. 包装数量: 1500/PCS/卷, 10卷/箱。
2. 包装袋长度: 每卷前后各空10-20个空格, 中间包装。
3. 材质:
载体: 聚丙烯 (PS),
上带: 聚乙烯 (PET),
卷盘: 聚苯乙烯。

纸箱规格: 345*345*23MM

纸箱规格: 345*345*35MM

THIS DOCUMENT IS THE SOLE PROPERTY OF BBJconn Technology Co.,Ltd. Corporation AND SHOULD NOT BE USED IN WHOLE OR IN PART WITHOUT PRIOR WRITTEN PERMISSION.		深圳市步步精科技有限公司 .X: ± 0.38 .X': $\pm 3'$.XX: ± 0.25 .X'': $\pm 2'$.XXX: ± 0.13 .X''': $\pm 1'$		NAME: 轻触开关 3x6x5 两脚贴片 方头 无柱 不锈钢弹片 260GF 全白 热封编带	
APPD.	JM_Zheng	PJ. NO.: TS.10.13-11-38-22 SIZE: A4 DRW NO.:		FINISH: SEE NOTES MAT'L.: SEE NOTES	
CHKD.	LYX	SCALE: N/A		REV.: A0	UNIT: mm
PDWG.NO:	0278-1	DR.	TSP	PAGE: 2/2	