

REV.	ECN NO	CONTENT	DATE	ENGINEER
AO				

技术要求:

1. 零部件表面光洁无划伤, 水花, 变形, 影响外观及性能等缺陷。
2. 额定电流: 50mA, 12V DC, 绝缘电阻100MΩ min, 100V DC, 介电强度250V AC for 1min, 接触电阻100mΩ max。
3. 开关手感明显, 档位清晰可靠, 无卡滞现象, 消除外力后, 应能快速回位。260±50GF
4. 带*尺寸与序号标记尺寸均为重点控制尺寸和记录尺寸。

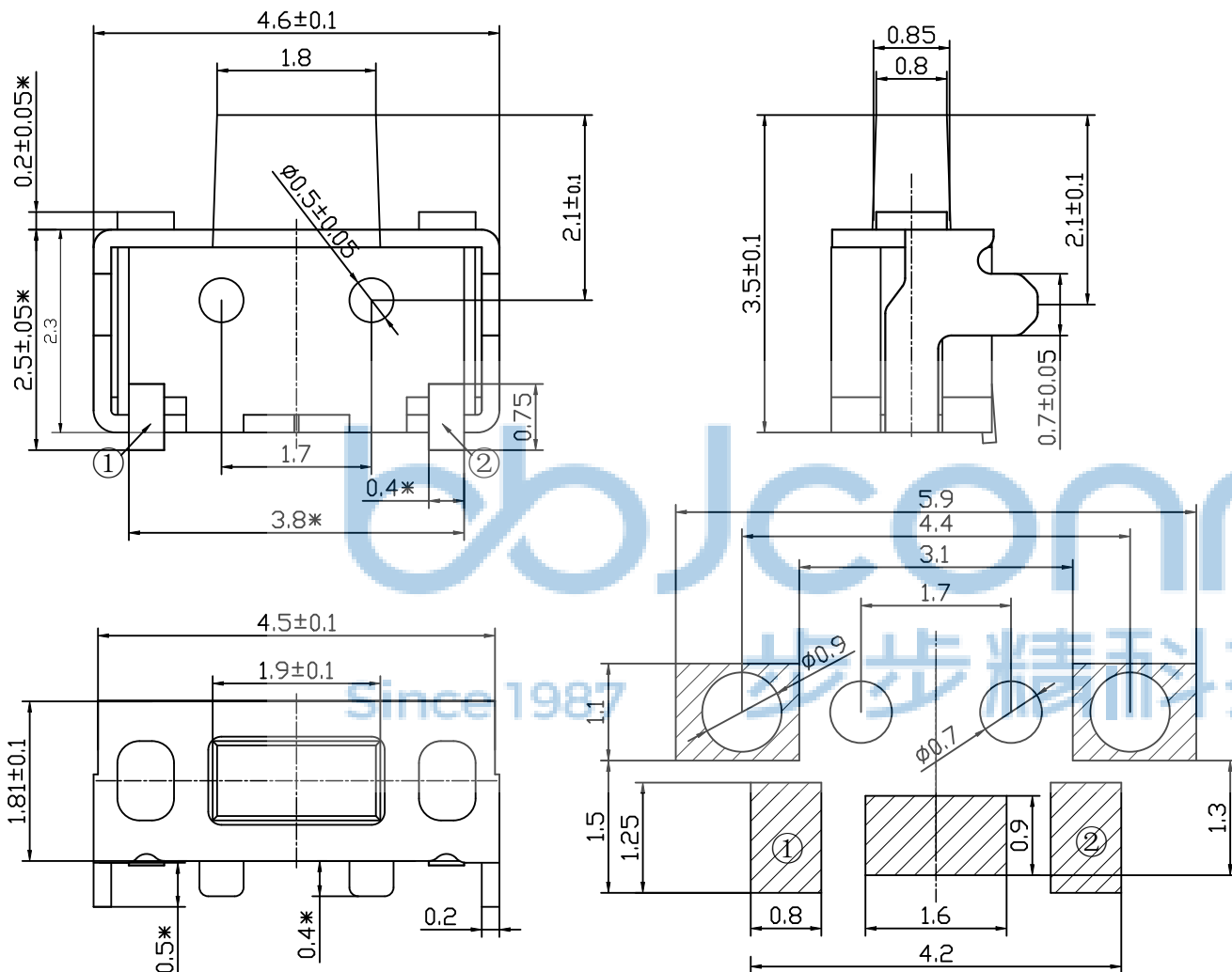

安装参考图

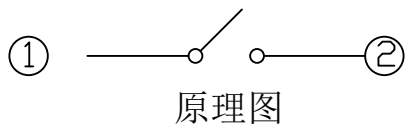

E	盖板	黄铜 0.2	1	镀银
D	按钮	LCP 黑	1	
C	簧片	进口不锈钢覆银	2	外购
B	底座	LCP (白)	1	
A	卡件	磷铜 0.15	1	镀银
序号	名称	材料	数量	备注

THIS DOCUMENT IS THE SOLE PROPERTY OF BBJconn Technology Co., Ltd. Corporation AND SHOULD NOT BE USED IN WHOLE OR IN PART WITHOUT PRIOR WRITTEN PERMISSION.
PDWG.NO: 0278-1

深圳市步步精科技有限公司

NAME: 轻触开关 2x4x3.5 侧插支架 带柱 0.5柱 不锈钢弹片 260gf

PJ. NO.: TS.05.73-51-38-01

SIZE: A4 | DRW NO.:

FINISH: SEE NOTES | MAT'L.: SEE NOTES

SCALE: N/A | REV.: AO | UNIT: mm | PAGE: 1/2

APPD.	JM_Zheng
CHKD.	LYX
DR.	TSP

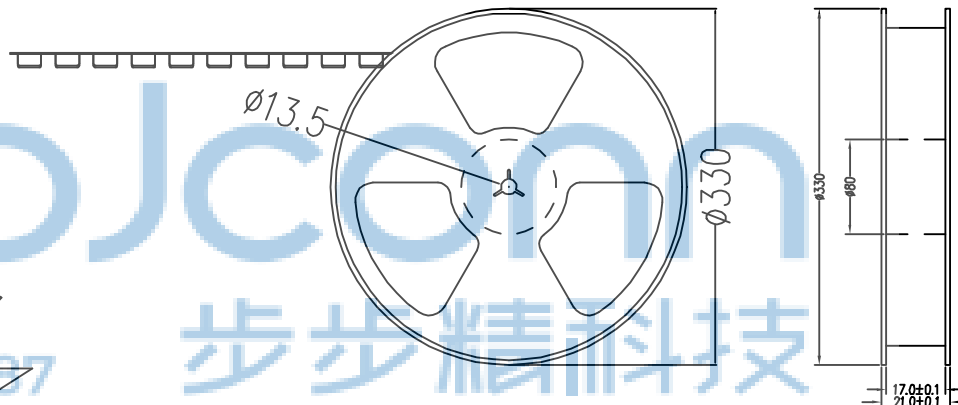
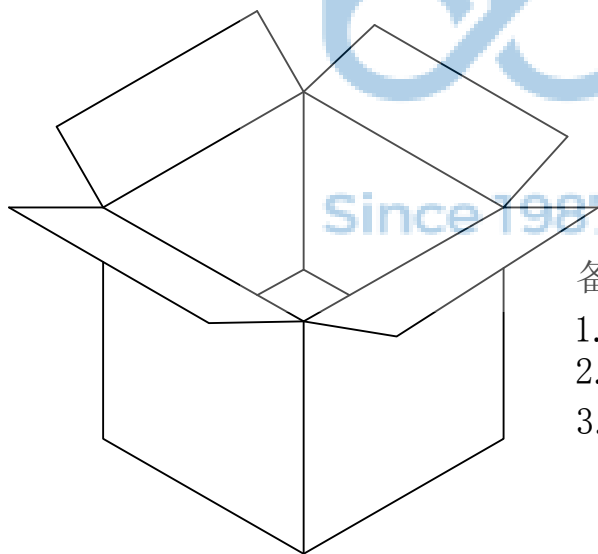
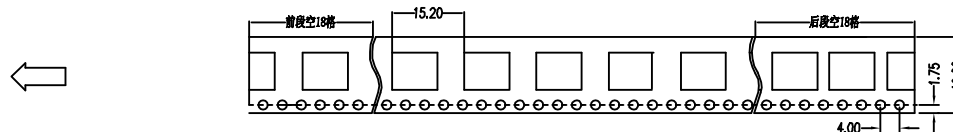
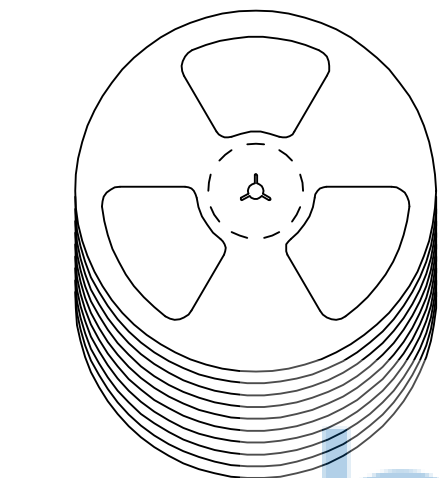

备注:

1. 包装数量: 3000/PCS/卷, 10卷/箱。
2. 包装袋长度: 每卷前后各空10-20个空格, 中间包装。
3. 材质:
载体: 聚丙烯 (PS), 阻抗 $10^{6-9} \Omega$
上带: 聚乙烯 (PET), 阻抗 $10^{6-11} \Omega$
卷盘: 聚苯乙烯。

纸箱规格: 345*345*23MM

纸箱规格: 345*345*35MM

THIS DOCUMENT IS THE SOLE PROPERTY OF BBJconn Technology Co.,Ltd. Corporation AND SHOULD NOT BE USED IN WHOLE OR IN PART WITHOUT PRIOR WRITTEN PERMISSION.		深圳市步步精科技有限公司	
.X: ±0.38 .XX: ±0.25 .XXX: ±0.13		X': ±3' X'': ±2' X'X': ±1'	
APPD.	JM_Zheng	NAME: 轻触开关 2x4x3.5 侧插支架 带柱 0.5柱 不锈钢弹片 260gf	
CHKD.	LYX	PJ. NO.: TS.05.73-51-38-01	
DR.	TSP	SIZE: A4 DRW NO.:	
PDWG.NO:	0278-1	FINISH: SEE NOTES MAT'L.: SEE NOTES	
		SCALE: N/A	REV.: AO UNIT: mm PAGE: 2/2