

| REV. | ECN NO. | CONTENT         | DATE | ENGINEER |
|------|---------|-----------------|------|----------|
| A0   |         | Initial release | /    | SGF      |

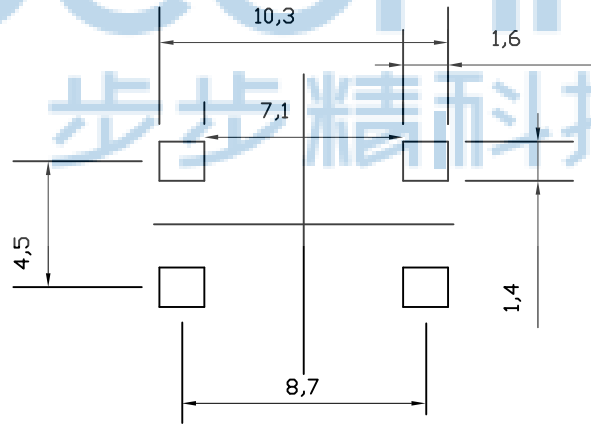
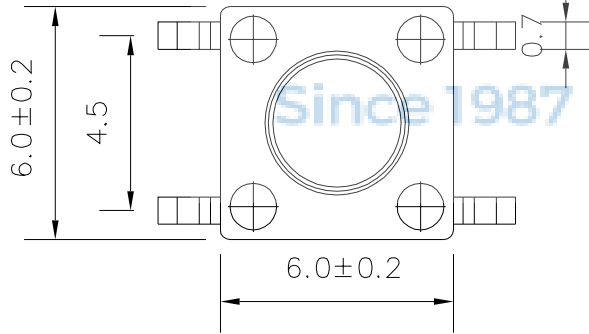
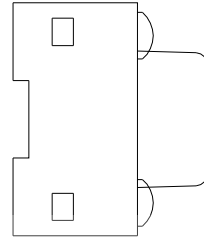
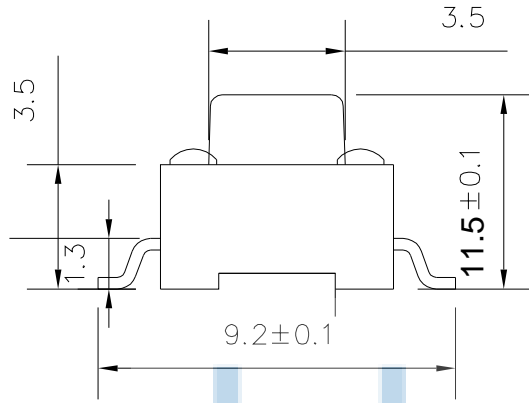

安装尺寸

|        |   |         |                      |
|--------|---|---------|----------------------|
| 主要技术参数 | 1 | 操作行程    | 0.25±0.1mm           |
|        | 2 | 额定电压、电流 | DC12V/50mA           |
|        | 3 | 接触电阻    | 30mΩ(max)            |
|        | 4 | 绝缘电阻    | 100MΩ(mi n)          |
|        | 5 | 耐 压     | 250V AC/1mi n        |
|        | 6 | 动 作 力   | 160/260 ± 30gf       |
|        | 7 | 使用寿命    | 80000次               |
|        | 8 | 尺 寸     | 未注公差均按 GB/T1804—2000 |

|    |    |   |               |       |
|----|----|---|---------------|-------|
| 4  | 弹片 | 1 | 不锈钢 SUS304    | 镀银/白色 |
| 3  | 按子 | 1 | PPA           | 黑色    |
| 2  | 盖板 | 1 | 铁 SPCC        | 镀银/白色 |
| 1  | 底座 | 1 | 黄铜与 PPA (H65) | 黑色与镀银 |
| 序号 | 名称 | 1 | 材料            | 镀涂/颜色 |



THIS DOCUMENT IS THE SOLE PROPERTY OF BBJconn Technology Co.,Ltd. Corporation AND SHOULD NOT BE USED IN WHOLE OR IN PART WITHOUT PRIOR WRITTEN PERMISSION.

PDWG.NO: 0013-1

APPD. JM\_Zheng  
CHKD. LYX  
DR. SGF

**深圳市步步精科技有限公司**

NAME: 轻触开关 6x6x11.5 贴片 不锈钢弹片 260G 9.2脚 袋装

PJ. NO.: TS.01.26-11-31-02  
SIZE: A4 | DRW NO.:  
FINISH: SEE NOTES | MAT'L.: SEE NOTES  
SCALE: N/A | REV.: A0 | UNIT: mm | PAGE: 1/2

| REV. | ECN NO | CONTENT         | DATE | ENGINEER |
|------|--------|-----------------|------|----------|
| A0   |        | Initial release | /    | SGF      |

PE袋规格:\*\*\*X\*\*\* (以实际出货为准)

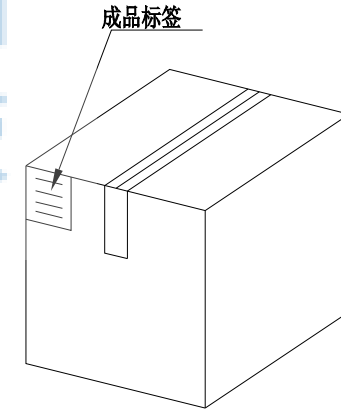
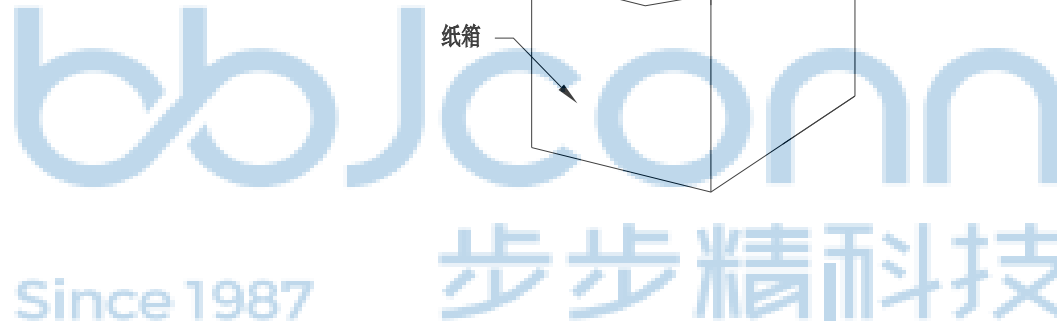
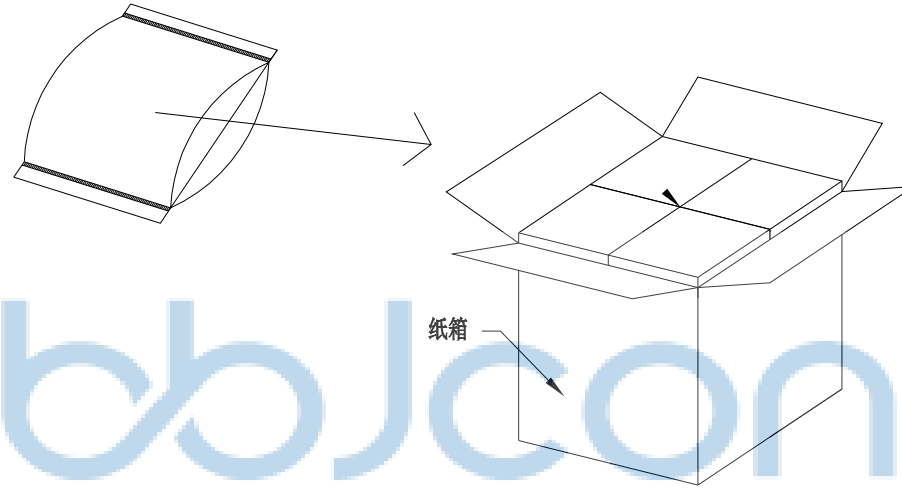

1. 包装要求:

- 1.1 每PE袋包装 500 pcs;
- 1.2 每1袋放一小纸盒;
- 1.3 每20个小纸盒放一个纸箱, 共计10000PCS
- 1.4 纸箱外贴上标签



|                                                                                                                                                            |          |                                                                                                                             |                             |
|------------------------------------------------------------------------------------------------------------------------------------------------------------|----------|-----------------------------------------------------------------------------------------------------------------------------|-----------------------------|
| THIS DOCUMENT IS THE SOLE PROPERTY OF BBJconn Technology Co.,Ltd. Corporation AND SHOULD NOT BE USED IN WHOLE OR IN PART WITHOUT PRIOR WRITTEN PERMISSION. |          | 深圳市步步精科技有限公司<br>.X: ±0.38 X': ±3' NAME:<br>.XX: ±0.25 .X": ±2' 轻触开关 6x6x11.5 贴片 不锈钢弹片 260G 9.2脚 袋装<br>.XXX: ±0.13 .XX": ±1' |                             |
| APPD.                                                                                                                                                      | JM_Zheng | PJ. NO.: TS.01.26-11-31-02<br>SIZE: A4 DRW NO.:                                                                             |                             |
| CHKD.                                                                                                                                                      | LYX      | FINISH: SEE NOTES MAT'L.: SEE NOTES                                                                                         |                             |
| PDWG.NO:                                                                                                                                                   | 0013-1   | DR.                                                                                                                         | SGF                         |
|                                                                                                                                                            |          | SCALE: N/A                                                                                                                  | REV.: A0 UNIT: mm PAGE: 2/2 |