

| REV. | ECN NO. | CONTENT | DATE | ENGINEER |
|------|---------|-----------------|------|----------|
| A0 | | Initial Release | / | LHC |

- 技术参数:
1. 做用温度: -25~+85°C;
 2. 额定负荷: DC 12V 50mA;
 3. 接触电阻: ≤50mΩ;
 4. 绝缘电阻: ≥100MΩ;
 5. 耐压: AC250V(50Hz)/min;
 6. 动作力: 160 /260GF ±50g;
 7. 使用寿命: 100000次;

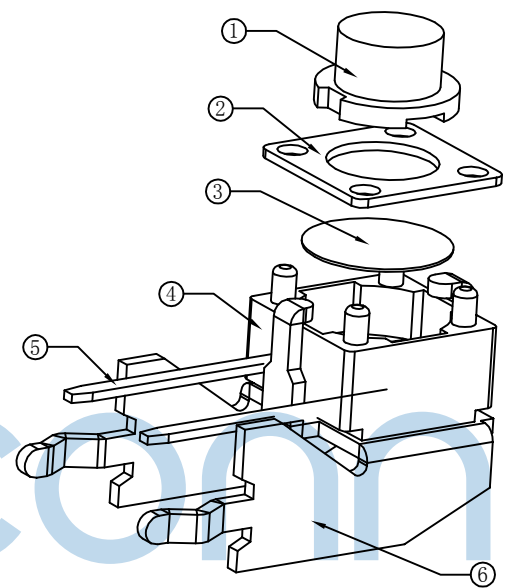

| 高度L (mm) | 帽头H (mm) | 直径A (mm) |
|----------|----------|----------|
| 13.85 | 15.0 | ∅3.0 |
| 11.85 | 13.0 | ∅3.0 |
| 8.35 | 9.5 | ∅3.1 |
| 7.85 | 9.0 | ∅3.2 |
| 7.35 | 8.5 | ∅3.2 |
| 6.35 | 7.5 | ∅3.3 |
| 5.35 | 6.5 | ∅3.3 |
| 4.85 | 6.0 | ∅3.3 |
| 3.85 | 5.0 | ∅3.5 |
| 3.15 | 4.3 | ∅3.5 |

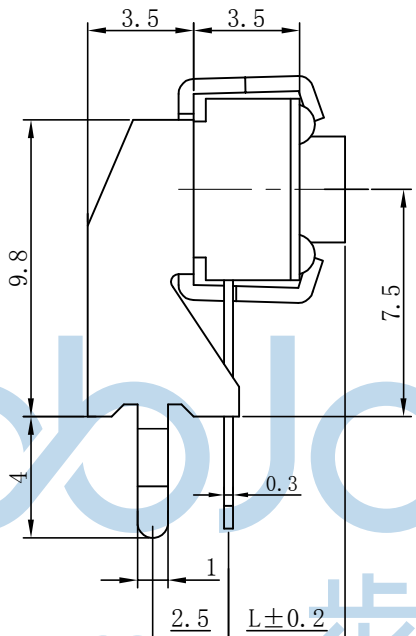
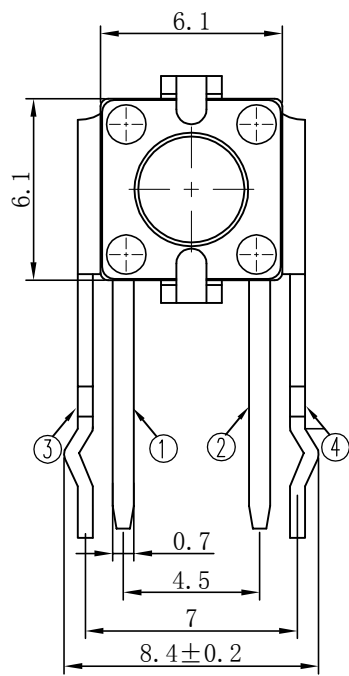
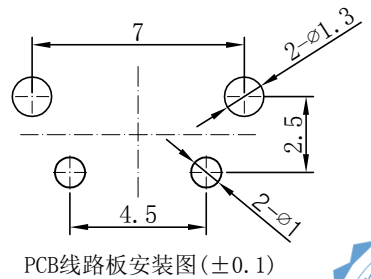
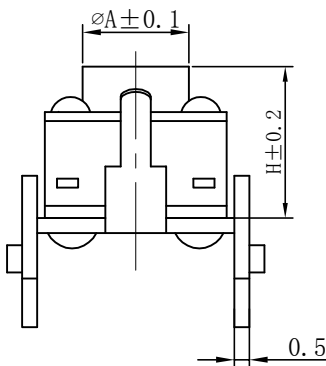

PCB线路板安装图(±0.1)

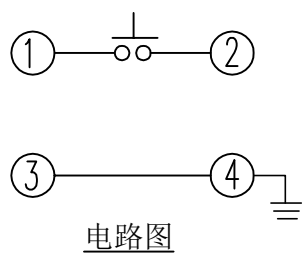

电路图



| 序号 | 名称 | 数量 | 材料 | 镀层/颜色 | 备注 |
|----|----|----|----------------|-------|----|
| 6 | 机架 | 1 | 冷轧钢带 | Cu/Sn | |
| 5 | 嵌件 | 1 | H62Y 黄铜 T=0.30 | Ag | |
| 4 | 底座 | 1 | PPA | 黑 | |
| 3 | 簧片 | 1 | 不锈钢/复合银 | Ag | |
| 2 | 盖板 | 1 | 冷轧钢带 | Cu/Sn | |
| 1 | 按钮 | 1 | PPA | 黑 | |



THIS DOCUMENT IS THE SOLE PROPERTY OF BBJconn Technology Co.,Ltd. Corporation AND SHOULD NOT BE USED IN WHOLE OR IN PART WITHOUT PRIOR WRITTEN PERMISSION.

PDWG.NO: 0013-1

DR. LHC

APPD. JM_Zheng

CHKD. LYX

NAME: 深圳市步步精科技有限公司
轻触开关 6x6x8.5 飞机架 不锈钢弹片 160GF

PJ. NO.: TS.01.20-B2-31-01

SIZE: A4 | DRW NO.:

FINISH: SEE NOTES | MAT'L.: SEE NOTES

SCALE: N/A | REV.: A0 | UNIT: mm | PAGE: 1/2

| REV. | ECN NO | CONTENT | DATE | ENGINEER |
|------|--------|-----------------|------|----------|
| A0 | | Initial Release | / | LHC |

PE袋规格: 260*185

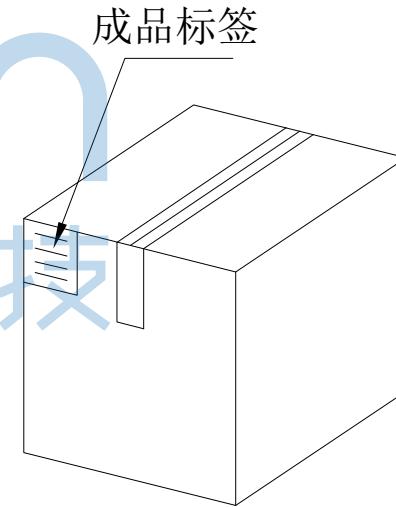
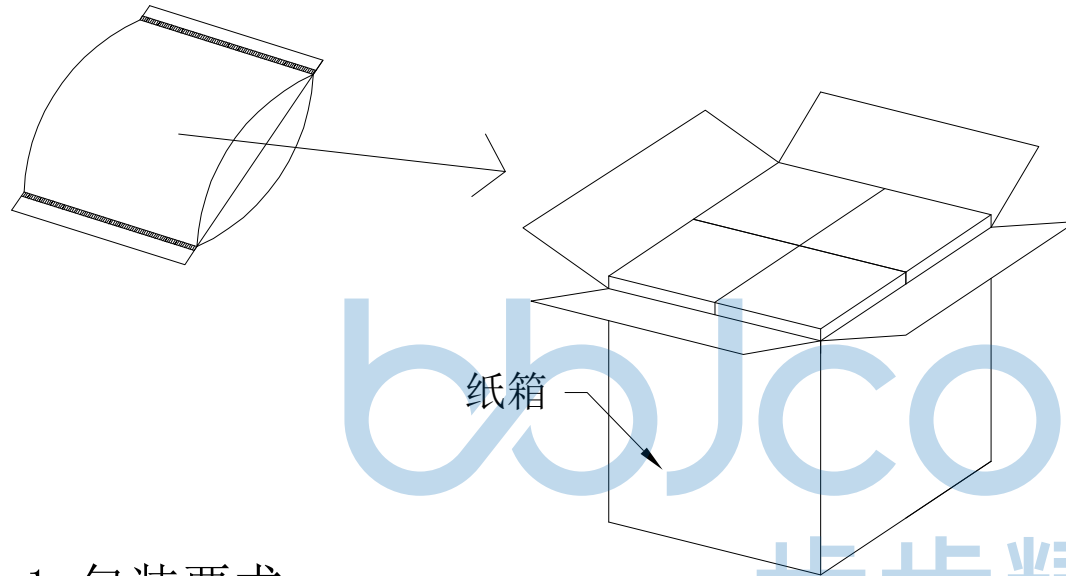

1. 包装要求:

- 1.1 每个PE袋包装 500 pcs ;
- 1.2 每1袋放一小纸盒;
- 1.3 每20个小纸盒放一个纸箱, 共计 10000 pcs ;
- 1.4 纸箱外贴上标签



| | | | | | |
|--|----------|--|-----|---------------------------------------|---------------------------------|
| THIS DOCUMENT IS THE SOLE PROPERTY OF BBJconn Technology Co.,Ltd. Corporation AND SHOULD NOT BE USED IN WHOLE OR IN PART WITHOUT PRIOR WRITTEN PERMISSION. | | 深圳市步步精科技有限公司 .X: ±0.38 .X': ±3" .XX: ±0.25 .X": ±2" .XXX: ±0.13 .X": ±1" | | NAME: 轻触开关 6x6x8.5 飞机架 不锈钢弹片 160GF | |
| APPD. | JM_Zheng | PJ. NO.: TS.01.20-B2-31-01 | | SIZE: A4 DRW NO.: | |
| CHKD. | LYX | FINISH: SEE NOTES | | MAT'L.: SEE NOTES | |
| PDWG.NO: | 0013-1 | DR. | LHC | SCALE: N/A | REV.: A0 UNIT: mm PAGE: 2/2 |