

REV.	ECN NO.	CONTENT	DATE	ENGINEER
A0		Initial release		LYX

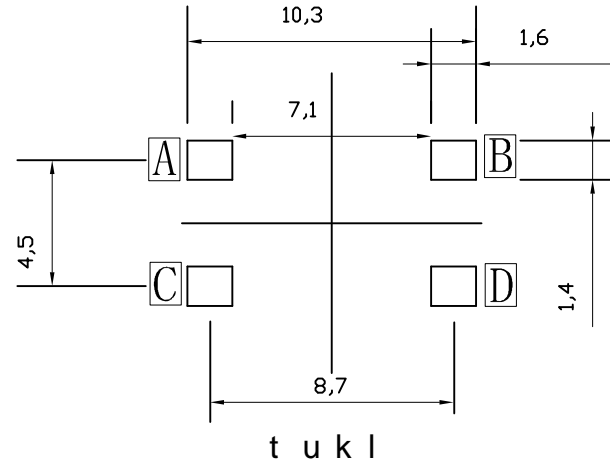
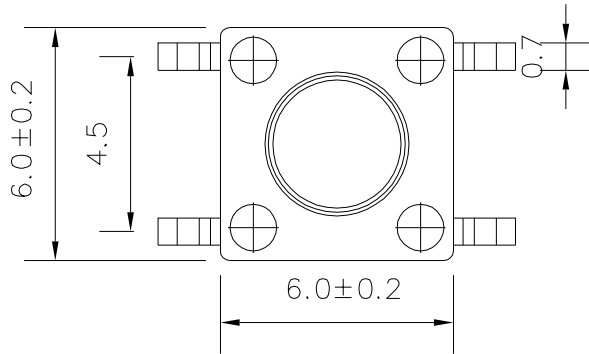
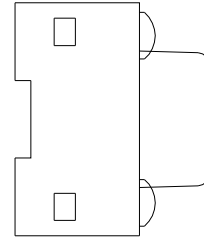
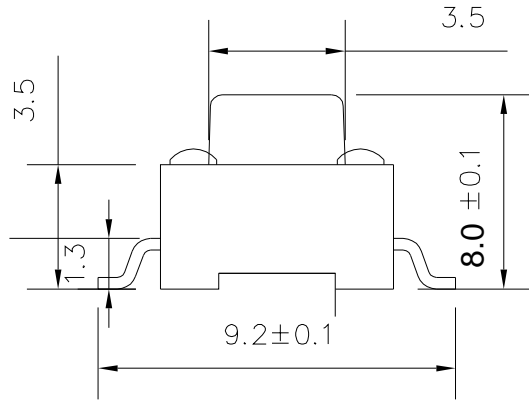

主要技术参数	1	操作行程	0.25±0.1mm
	2	额定电压、电流	DC12V/50mA
	3	接触电阻	30mΩ(max)
	4	绝缘电阻	100MΩ(mi n)
	5	耐 压	250V AC/1mi n
	6	动 作 力	160/260 ± 30gf
	7	使用寿命	80000次
	8	尺 寸	未注公差均按 GB/T1804—2000

4	弹片	1	不锈钢 SUS304	1/16"±0.05"
3	接子	1	PPA	黑色
2	盖板	1	铁 SPCC	1/16"±0.05"
1	底座	1	黄铜与 PPA (H65)	黑色与镀银
序号	名称	1	材料	镀涂/颜色

THIS DOCUMENT IS THE SOLE PROPERTY OF BBJconn Technology Co.,Ltd. Corporation AND SHOULD NOT BE USED IN WHOLE OR IN PART WITHOUT PRIOR WRITTEN PERMISSION. PDWG.NO: 0013-1

**JD** \$! c 2!•2i0 ° 9L€ œ (

.X: ±0.38	.X': ±3'	NAME:
.XX: ±0.25	.X': ±2'	Çá ¥¿ a1Ø 6x6x8 ìùÆ¬²»Đà, Öm̄Æ¬ 260G 9.2½Å
.XXX: ±0.13	.XX': ±1'	
APPD.	JM_Zheng	PJ. NO.: TS.01.19-11-31-04
CHKD.	TSP	SIZE: A4 DRW NO.:
DR.	LYX	FINISH: SEE NOTES MAT'L.: SEE NOTES
		SCALE: N/A REV.: A0 UNIT: mm PAGE: 1/2

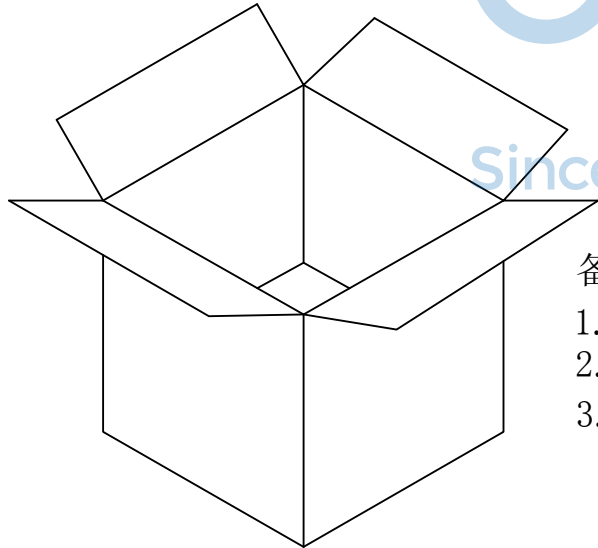
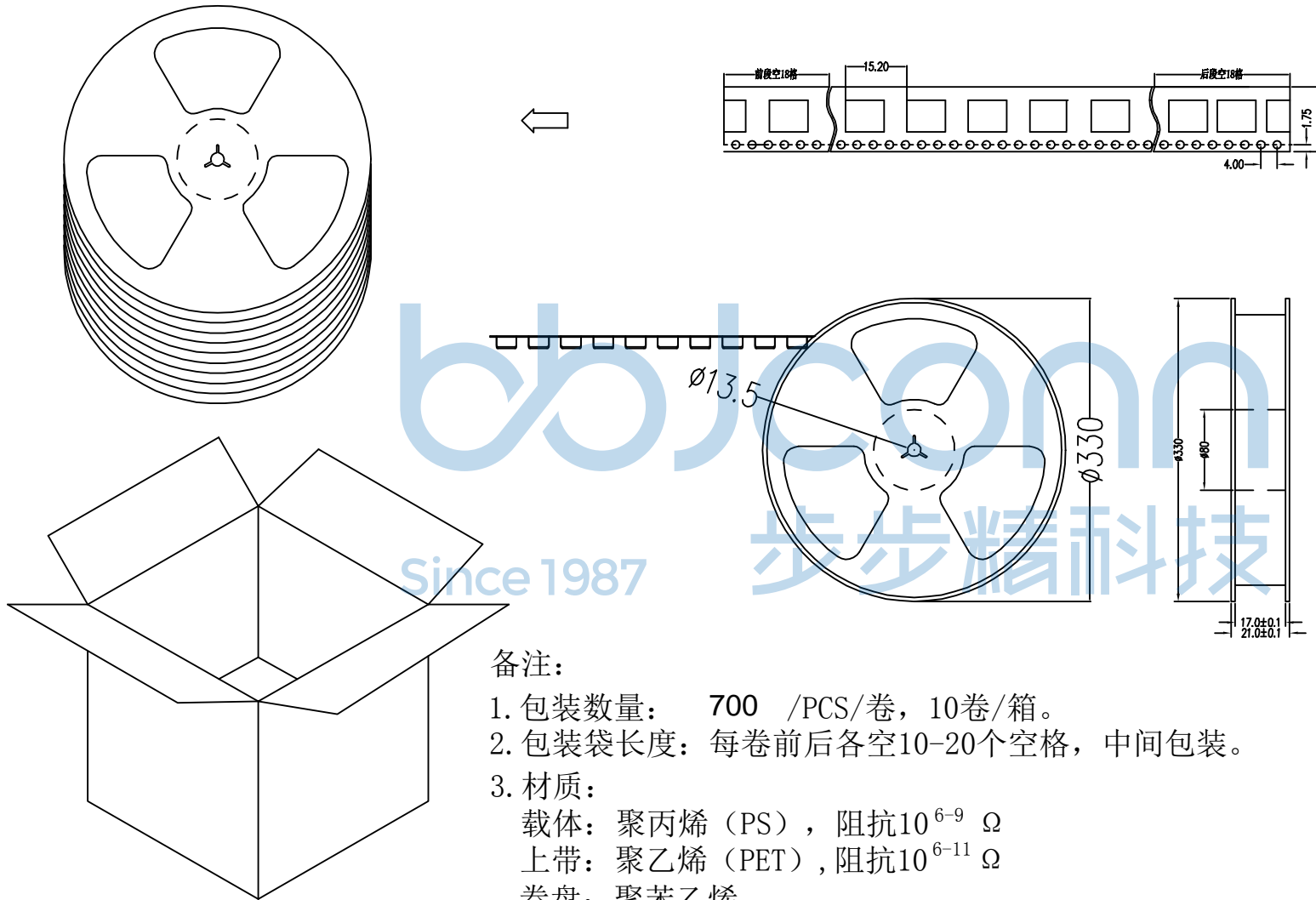

备注:

1. 包装数量: 700 /PCS/卷, 10卷/箱。
2. 包装袋长度: 每卷前后各空10-20个空格, 中间包装。
3. 材质:  
 载体: 聚丙烯 (PS), 阻抗 $10^{6-9} \Omega$   
 上带: 聚乙烯 (PET), 阻抗 $10^{6-11} \Omega$   
 卷盘: 聚苯乙烯。

纸箱规格: 345\*345\*23MM

THIS DOCUMENT IS THE SOLE PROPERTY OF BBJconn Technology Co.,Ltd. Corporation AND SHOULD NOT BE USED IN WHOLE OR IN PART WITHOUT PRIOR WRITTEN PERMISSION.		\$! c 2!•2i0 ° 9L€ œ (	
PDWG.NO: 0013-1		APPD. JM_Zheng CHKD. TSP DR. LYX	NAME: Ǫá ¥¿ a1Ø 6x6x8 ùÈ- 2»Đà, Öμ-Æ- 260G 9.2%Å PJ. NO.: TS.01.19-11-31-04 SIZE: A4   DRW NO.: FINISH: SEE NOTES   MAT'L.: SEE NOTES SCALE: N/A   REV.: A0   UNIT: mm   PAGE: 2/2