

RECOMMENDED PCB LAYOUT
TOLERANCE: ±0.05
(建议使用刷钢板厚度0.12mm)

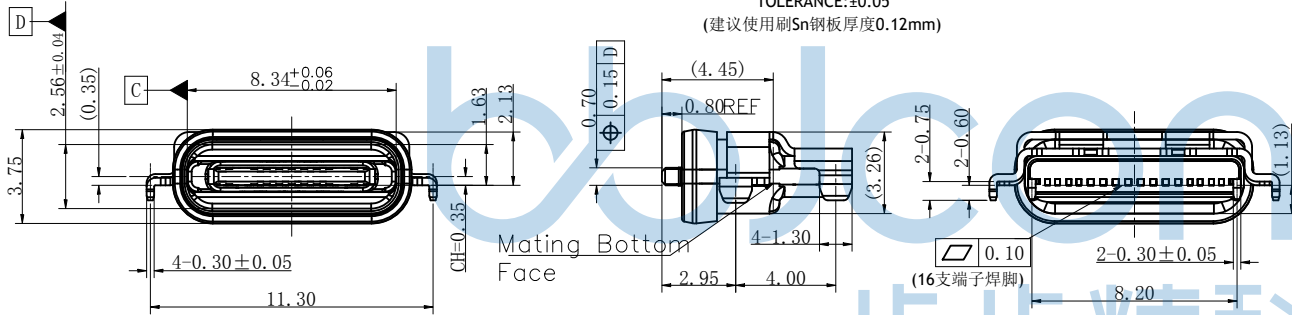

Mating Bottom Face

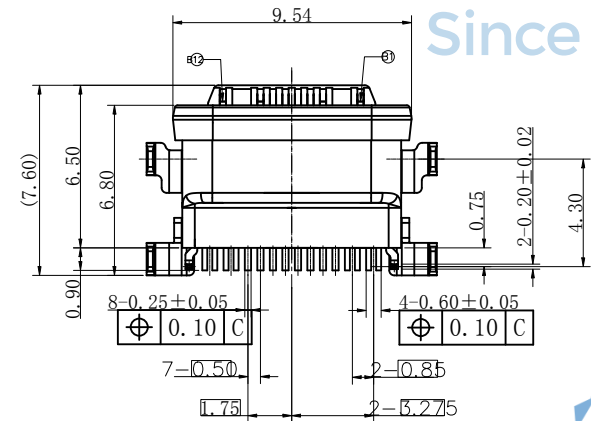

Mated Condition(REF.)

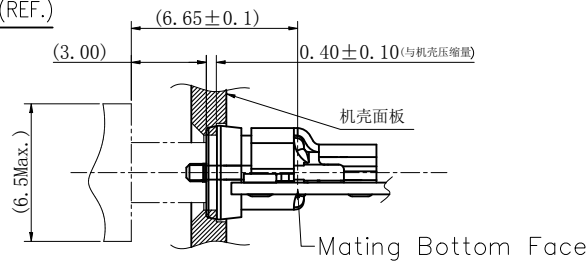

Mating Bottom Face



REV.	ECN NO	CONTENT	DATE	ENGINEER
A0		Initial release	/	TSP

- NOTES:
- MATERIAL SPECIFICATION:
 - 1-1. HOUSING: High-Temp Plastics PA10T, UL94V-0, Color: BLACK
 - 1-2. CONTACTS: C1815 T=0.25mm.
 - 1-3. OUTER SHELL: SUS 304 Steel, T=0.30mm.
 - 1-4. INNER SHELL: SUS 316L Steel, T=0.20mm.
 - 1-5. MID-PLATE: SUS 304, T=0.20mm.
 - 1-6. SOLDER-PLATE: SUS 301, T=0.10mm.
 - PLATING SPECIFICATION:
 - 2-1. CONTACTS:
 - Ni UNDERPLATED OVER ALL;
 - Au 3u" Plated On Contact Area;
 - Gold Flash Plated On Solder Area.
 - 2-2. SHELL:
 - Ni UNDERPLATED OVER ALL;
 - Gold Flash Plated ON Solder Leg.
 - RoHS COMPLIANT.
 - MECHANICAL PERFORMANCE:
 - 4-1. MATING FORCE: 5~20N
 - 4-2. UNMATING FORCE: 8~20N(Initial); 6~20N(After)
 - 4-3. DURABILITY: 10000 CYCLES.
 - ELECTRICAL PERFORMANCE:
 - 5-1. CURRENT RATING: 5A; VOLTAGE RATING: 5V
 - 5-2. LLCR:
 - VBUS & GND PINS: 40mΩ/PIN MAX.;
 - OTHERS PINS: 40mΩ/PIN MAX.;
 - LLCR MAX. CHANGE OF ALL PINS: 10mΩ.
 - 5-3. INSULATION RESISTANCE: 100MΩ MIN.
 - 5-4. DIELECTRIC WITHSTANDING VOLTAGE: 100V AC FOR 1 MINUTE.
 - ENVIRONMENTAL PERFORMANCE:
 - OPERATING TEMPERATURE: -20°C~+85°C.
 - RECOMMENDED PROCESS:
 - THE PEAK TEMPERATURE ON THE BOARD SHALL MAINTAIN 10±1 SECONDS AT 260±5°C.

Contact Number	Signal Name	Contact Number	Signal Name
A1	GND	B12	GND
A4	VBUS	B9	VBUS
A5	CC1	B8	SBU2
A6	Dp1	B7	Dn2
A7	Dn1	B6	Dp2
A8	SBU1	B5	CC2
A9	VBUS	B4	VBUS
A12	GND	B1	GND



THIS DOCUMENT IS THE SOLE PROPERTY OF BBJconn Technology Co., Ltd. Corporation AND SHOULD NOT BE USED IN WHOLE OR IN PART WITHOUT PRIOR WRITTEN PERMISSION. PDWG.NO: 0085-1

深圳市步步精科技有限公司

NAME: TYPE-C 16P 防水母座 四脚插 端子SMT 8A电流 液态硅胶圈不配防水圈 沉板1.13 L=6.80 CH=0.35 舌片外漏0.80 IPX7 编带

APPD. JM_Zheng
CHKD. LYX
DR. TSP

PJ. NO.: UC.01.31-1W-0018
SIZE: A4 DRW NO.:
FINISH: SEE NOTES MAT'L.: SEE NOTES
SCALE: N/A REV.: A0 UNIT: mm PAGE: 1/2

REV.	ECN NO	CONTENT	DATE	ENGINEER
A0		Initial release	/	TSP

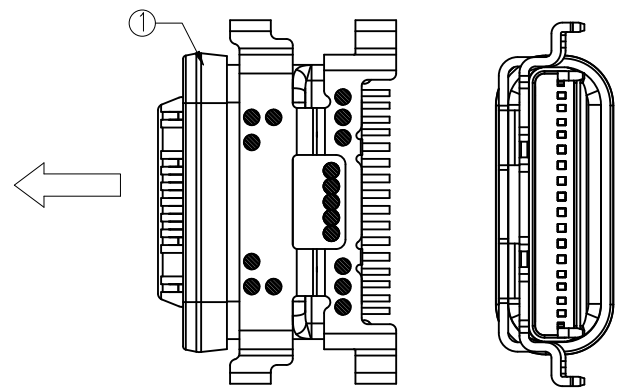
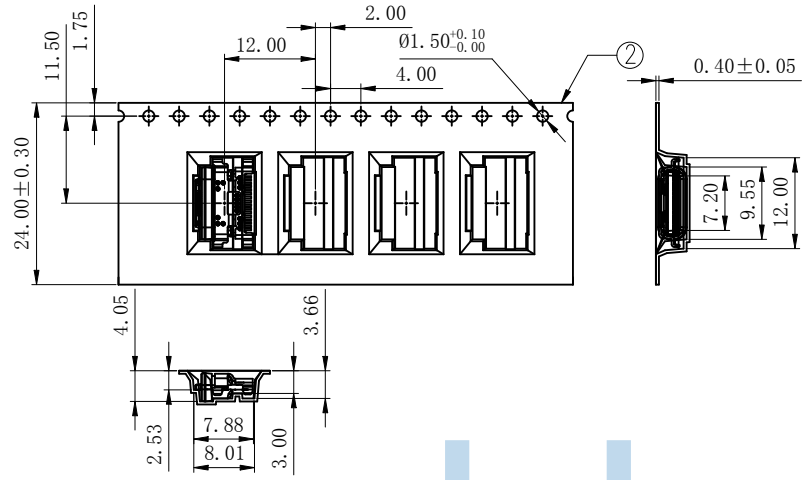

Notes:
 1. Quantity/Reel:1300pcs/Reel
 数量/卷:1300pcs/卷
 Quantity/OuterCarton:1300 *10=13000 pcs
 数量/外箱:1300 *10=13000 pcs
 2. Weight:
 N.W:6.1Kg G.W:10.910.9±0.5Kg
 0.5Kg
 净重:6.1Kg 毛重:10.9±0.5Kg
 3. Free 22 pcs Products In the Front Carrier And
 Free pcs Products In the End Carrier.
 载带前后各空22格.

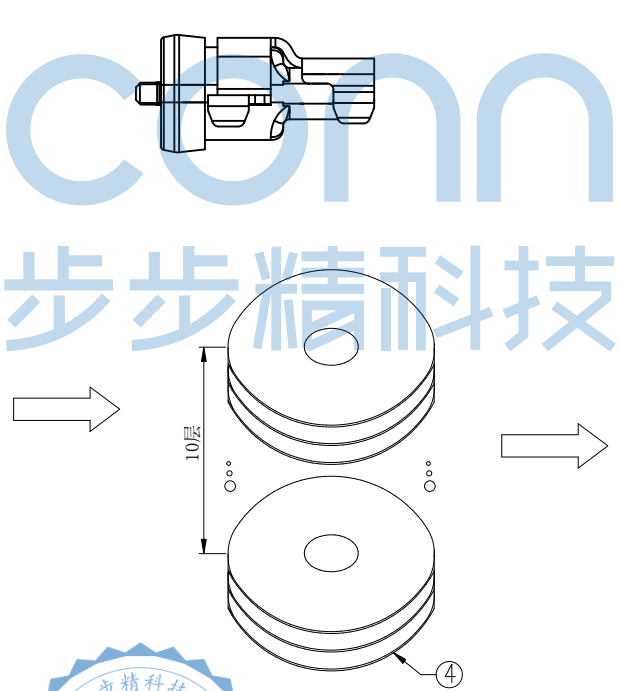
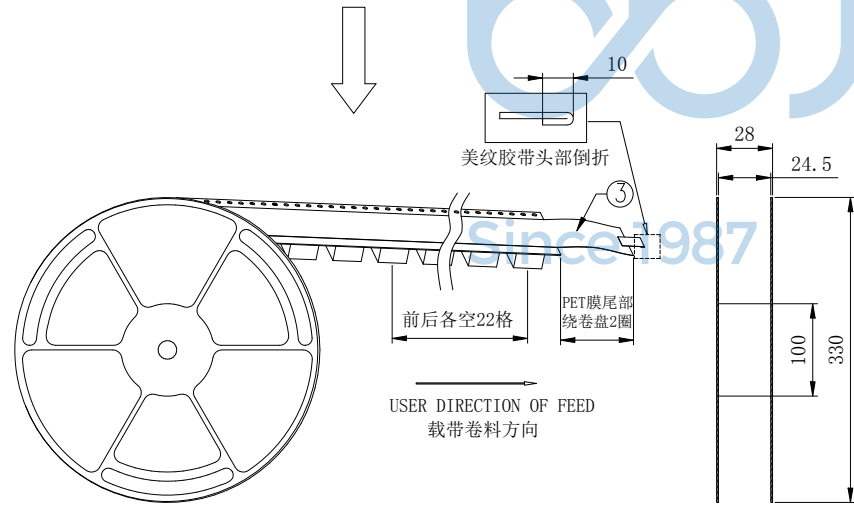

⑥	Outer Carton	1	K=K	35*35*33cm ³
⑤	PE Beg	1	PE	(400+250)x800x0.06mm
④	Paper Reel	10	White paper Plate	Ø330mm
③	Cover Tape	18.202m	PET	t=0.06mm,W=21.3mm
②	Carrier Tape	16.128m	Transparent PET	t=0.30mm
①	Product	1300		
NO.	PART NAME	Q'TY	MATERIAL	REMARKS



THIS DOCUMENT IS THE SOLE PROPERTY OF BBJconn Technology Co., Ltd. CORPORATION AND SHOULD NOT BE USED IN WHOLE OR IN PART WITHOUT PRIOR WRITTEN PERMISSION.		深圳市步步精科技有限公司 .X: ±0.38 .X': ±3" .XX: ±0.25 .X": ±2" .XXX: ±0.13 .XX': ±1"	
APPD.	JM_Zheng	NAME: TYPE-C 16P 防水母座 四脚插 端子SMT 8A电流 液态硅胶圈不配防水圈 沉板1.13 L=6.80 CH=0.35 舌片外漏0.80 IPX7 编带	
CHKD.	LYX	PJ. NO.: UC.01.31-1W-0018	
DR.	TSP	SIZE: A4 DRW NO.:	
PDWG.NO: 0085-1		FINISH: SEE NOTES MAT'L.: SEE NOTES	
		SCALE: N/A REV.: A0 UNIT: mm PAGE: 2/2	