

REV.	ECN NO	CONTENT	DATE	ENGINEER
A0		Initial release	2023.10.16	Yan

NOTES:

- MATERIAL: SEE "TABLE 1";
- FINISH: SEE "TABLE 1";
- ELECTRICAL :
 - 3-1.CONTACT CURRENT RATING :
5A(VBUS PIN 1.5A/PIN),
5A(GND PIN 1.25A/PIN MAX),0.25A/PIN(OTHER PIN).
 - 3-2.INSULATION RESISTANCE :
100 MEGAOHMS MIN. AT 250VDC.
 - 3-3.DIELECTRIC WITHSTANDING VOLTAGE :
100VAC MIN.
 - 3-4.LOW LEVEL CONTACT RESISTANCE :
INITIAL 40mΩ MAX.
AFTER 50mΩ MAX.
- MECHANICAL CHARACTERISTICS :
 - 4-1. MATING FORCE: 5~20N.
 - 4-2. UNMATING FORCE: 8~20N(INITIAL),6~20N(AFTER 10000 CYCLES)
 - 4-3.DURABILITY : 10,000 MATING CYCLES.
 - 4-4.OPERATING TEMPERATURE : -40°C TO +80°C

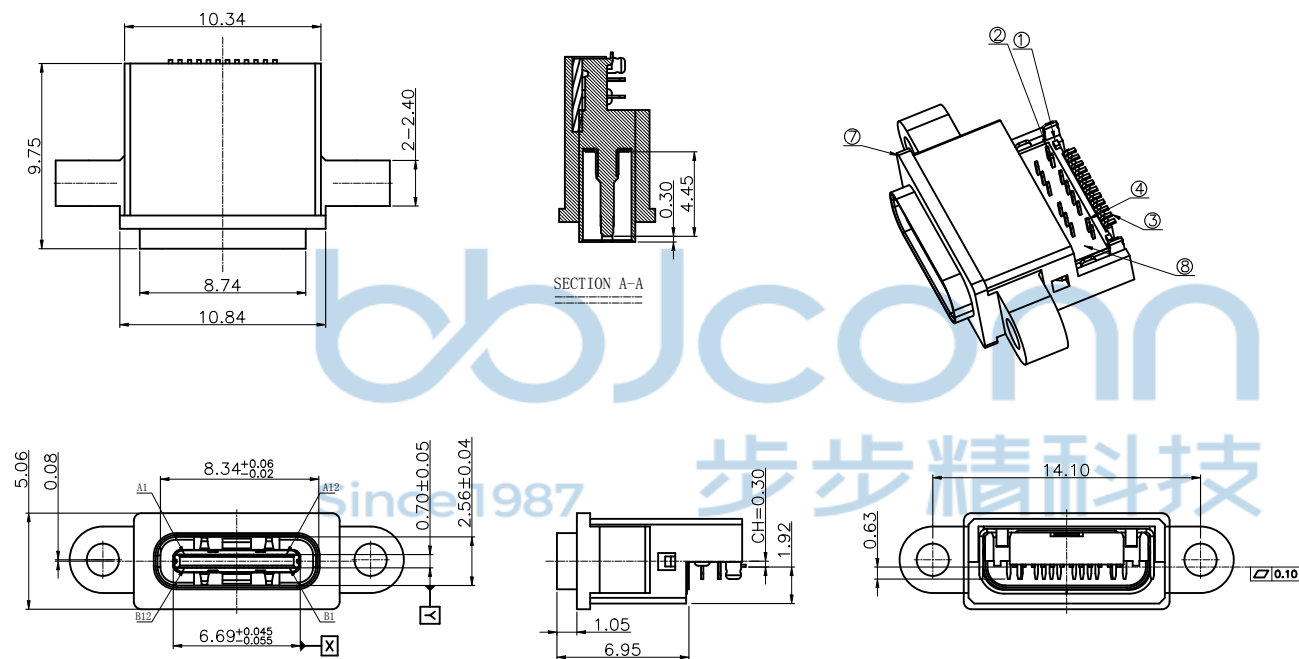

TABLE 1:

NO.	PART NAME	QTY	MATERIAL	DESCRIPTION	REMARK
⑧	Glue Water	1	Epoxy	BLACK;	
⑦	Plastic	1	HIGH TEMP NYLON	Black	
⑥	Shell	1	Stainless steel	PEARL NI PLATING;	T=0.20mm
⑤	GND PLATE	1	Stainless steel	NI PLATING;	T=0.10mm
④	MID PLATE	1	Stainless steel		T=0.15mm
③	Terminal-B	12	C7025	CONTACT AREA:AU15u"	T=0.12mm
②	Terminal-A	12		CONTACT AREA:AU15u"	T=0.12mm
①	Housing	1	HIGH TEMP NYLON	Black	

THIS DOCUMENT IS THE SOLE PROPERTY OF		深圳市步步精科技有限公司	
BBJconn Technology Co.,Ltd.		NAME: TYPE-C 24P 母座 SMT 端子镀金15u 前插后贴 锁板式 沉板1.92 L=9.75 CH=0.30 防水IPX7 编带	
NOT BE USED IN WHOLE OR IN PART WITHOUT PRIOR WRITTEN PERMISSION.	APPD. JM_Zheng	FINISH: SEE NOTES	MAT'L.: SEE NOTES
PDWG.NO: 0842-1	DR. YAN	SCALE: N/A	REV.: A0 UNIT: mm PAGE: 1/3



RECOMMENDED P.C.B LAYOUT(Both sides are sample)
Tolerance:±0.05,Thickness=0.60mm



密封方式

机壳面板

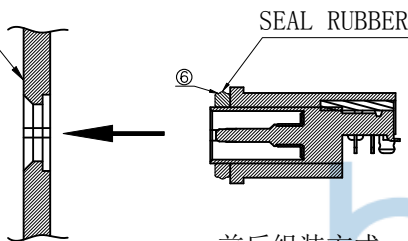

前后组装方式

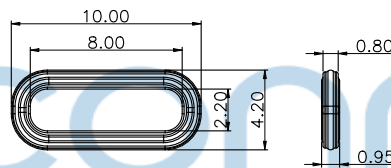

Seal Rubber For Reference

Space(Panel with Seal Rubber)0.30Min
(The amount of compression is recommended as 40%~50% of seal rubber O.D.)

Space(Panel with Seal Rubber)0.30Min
(The amount of compression is recommended as 40%~50% of seal rubber O.D.)

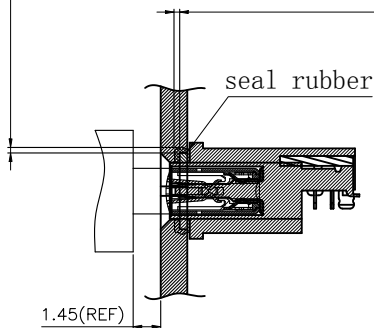

Recommended Assembly



Pin	Signal Name	Mating Sequence	Pin	Signal Name	Mating Sequence
A1	GND	First	B12	GND	First
A2	SSTXp1	Second	B11	SSRXp1	Second
A3	SSTXn1	Second	B10	SSRXn1	Second
A4	V _{BUS}	First	B9	V _{BUS}	First
A5	CC1	Second	B8	SBU2	Second
A6	Dp1	Second	B7	Dn2	Second
A7	Dn1	Second	B6	Dp2	Second
A8	SBU1	Second	B5	CC2	Second
A9	V _{BUS}	First	B4	V _{BUS}	First
A10	SSRXn2	Second	B3	SSTXn2	Second
A11	SSRXp2	Second	B2	SSTXp2	Second
A12	GND	First	B1	GND	First
SHELL		GND	SHELL		GND

THIS DOCUMENT IS THE SOLE PROPERTY OF BBJconn Technology Co.,Ltd. Corporation AND SHOULD NOT BE USED IN WHOLE OR IN PART WITHOUT PRIOR WRITTEN PERMISSION.		深圳市步步精科技有限公司	
PDWG.NO: 0842-1		APPD. JM_Zheng	NAME: TYPE-C 24P 母座 SMT 端子镀金15u 前插后贴 锁板式 沉板1.92 L=9.75 CH=0.30 防水IPX7 编带
CHKD. TSP	DR. YAN	PJ. NO.:126-223-240001-W2G	SIZE: A4 DRW NO.: CC23-0020
		FINISH: SEE NOTES	MAT'L.: SEE NOTES
		SCALE: N/A	REV.: A0 UNIT: mm PAGE: 2/3

REV.	ECN NO	CONTENT	DATE	ENGINEER
A0		Initial release	2023.10.16	Yan

- 包装方式:
- 第一步: 产品使用包装机入包装盘
- (1) 首先将包装盘贴上标签
 - (2) 再将成品按照规定的所示方向摆放于料带中进行包装
 - (3) 每盘包装数量700PCS成品
- 第二步: 包装盘入外箱
- (1) 每个PE袋中放入四包干燥剂.
 - (2) 共10盘/7000PCS放入置入外箱的PE袋中
- 第三步: 外箱封口&贴标签
- (1) 先确认外箱里是否有10盘产品
 - (2) 包装完成后使用透明胶带封口, 贴LABEL于规定的位置
- 第四步: 储存&运输
- (1) 储存在通风, 干燥环境; 搬运时轻柔轻放

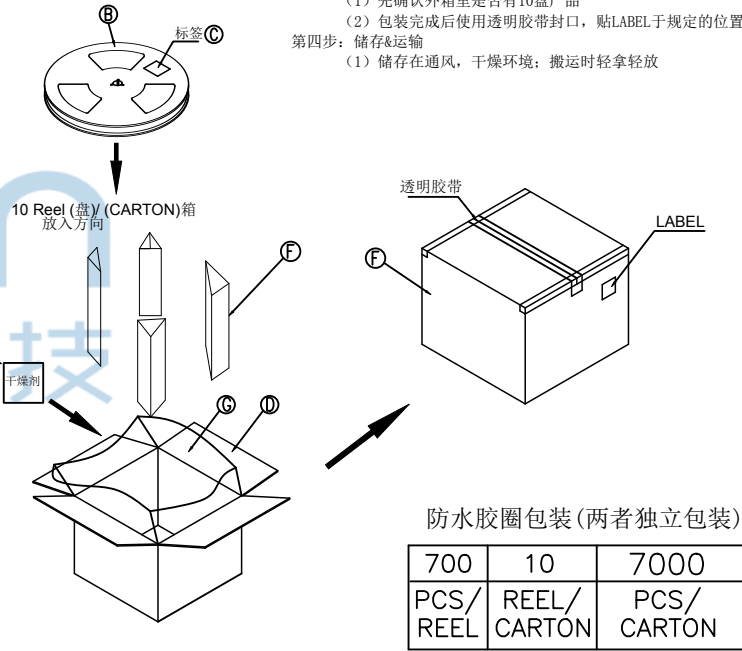
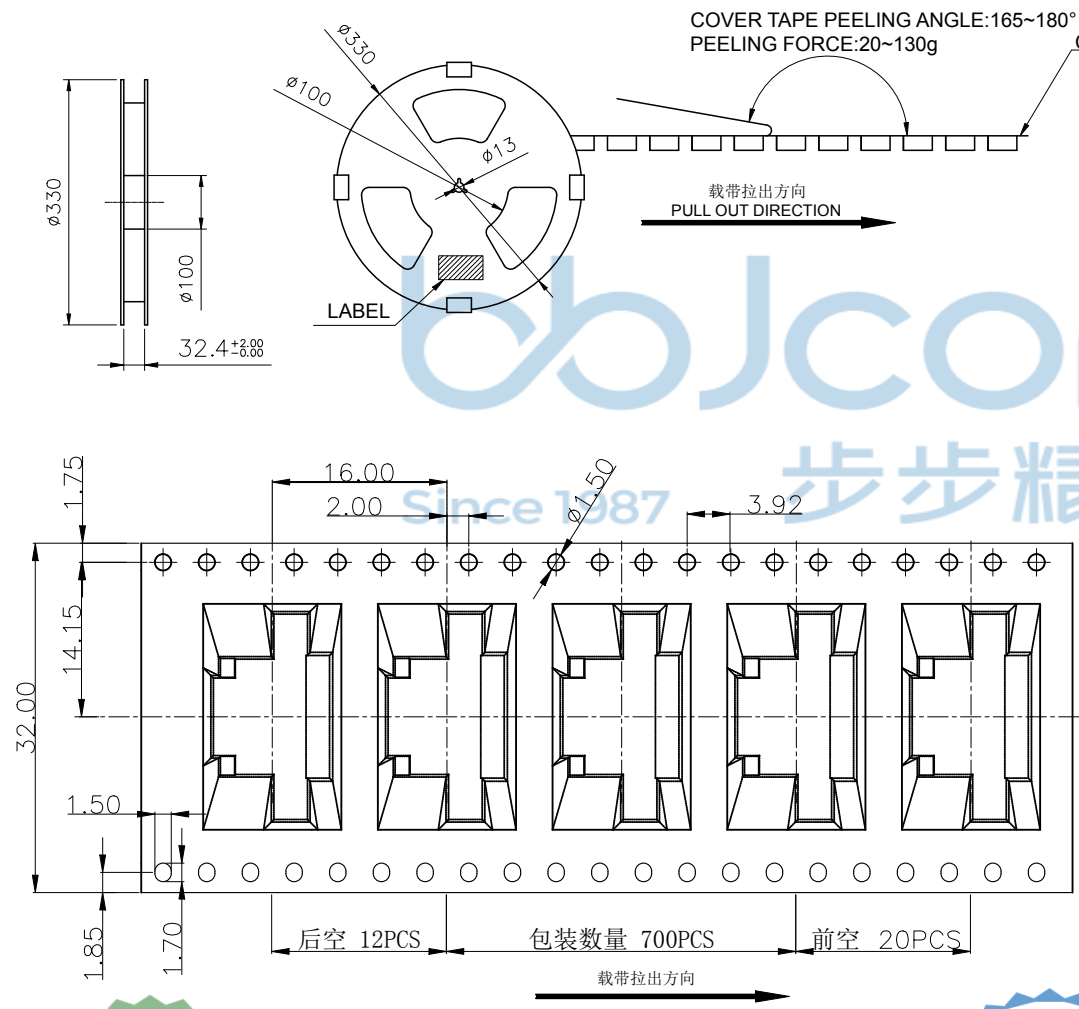

防水胶圈包装(两者独立包装)

700	10	7000
PCS/ REEL	REEL/ CARTON	PCS/ CARTON

表格1:

NO	DESCRIPTION	Q'TA(PCS)
G	PE袋	1
F	三角护柱	4
E	干燥剂	4
D	纸箱	1
C	标签	11
B	REEL	10
A	TYPE C	7000



THIS DOCUMENT IS THE SOLE PROPERTY OF BBJconn Technology Co., Ltd. Corporation AND SHOULD NOT BE USED IN WHOLE OR IN PART WITHOUT PRIOR WRITTEN PERMISSION. PDWG.NO: 0842-1

深圳市步步精科技有限公司

NAME: TYPE-C 24P 母座 SMT 端子镀金15u 前插后贴 锁板式 沉板1.92 L=9.75 CH=0.30 防水IPX7 编带

PJ. NO.: 126-223-240001-W2G
SIZE: A4 DRW NO.: CC23-0020

FINISH: SEE NOTES MAT'L: SEE NOTES
SCALE: N/A REV.: A0 UNIT: mm PAGE: 3/3

APPD. JM_Zheng
CHKD. TSP
DR. YAN