

REV.	ECN NO	CONTENT	DATE	ENGINEER
A0		Initial release	2023 07/21	JM_Zheng
A1	EN2308014	外壳边缘由3.86改为4.36	2023 08/23	JM_Zheng
A2	EN2312003	Nylon改为LCP	2023 12/13	JM_Zheng

PIN	SIGNAL NAME	PIN	SIGNAL NAME
A1	GND	B12	GND
A2		B11	
A3		B10	
A4		B9	
A5	CC1	B8	SBU2
A6	Dp1	B7	Dn2
A7	Dn1	B6	Dp2
A8	SBU1	B5	CC2
A9	VBUS	B4	VBUS
A10		B3	
A11		B2	
A12	GND	B1	GND

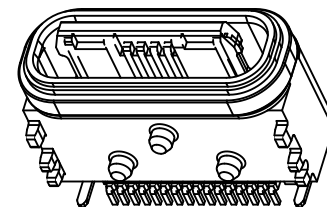

- NOTES:
- ELECTRICAL:
 - CONTACT CURRENT RATING 5.0A FOR VBUS AND GND(PINS A4 A9 B4 B9)
 - INSULATION RESISTANCE: 100 MEGAOHMS MIN. AT 250VDC.
 - DIELECTRIC WITHSTANDING VOLTAGE: 100VAC MIN.
 - LOW CONTACT RESISTANCE: INITIAL 40mΩ MAX. AFTER 50mΩ MAX.
 - MECHANICAL CHARACTERISTICS:
 - INSERTION FORCE:5N~20N.
 - EXTRACTION FORCE: 8N~20N FORM 1 TO 1000CYCLES. 6~20N FORM 1001 TO 10000CYCLES.
 - DURABILITY:10,000 MATING CYCLES
 - OPERATING TEMPERATURE:-55°C TO +85°C
 - COPLANARITY:0.08MAX.
 - INSPECTION SYMBOL: IMPORTANCE INSPECTION.
 - Waterproof Level:IPX7
 - ▼:重点尺寸标记, ▼:巡检尺寸标记.

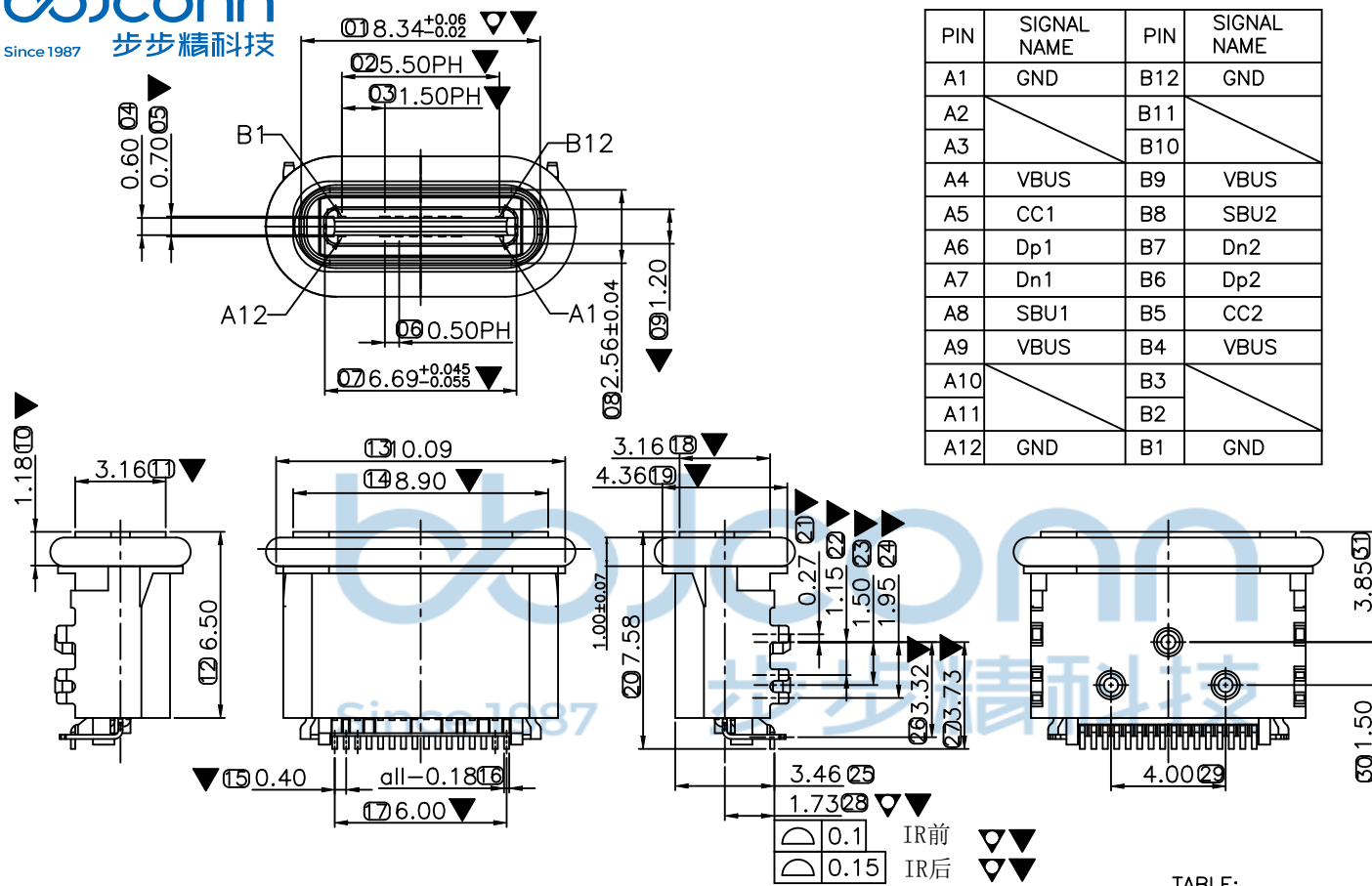
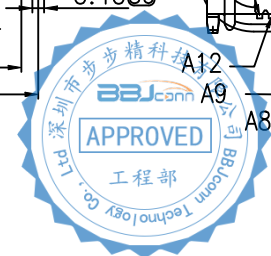
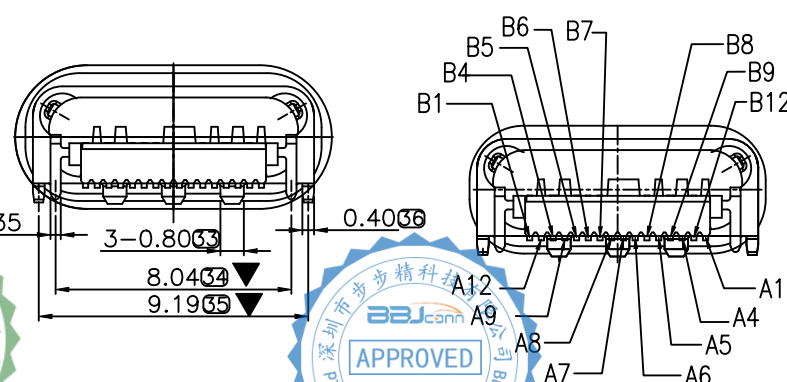

TABLE:

ITEM	PART NAME	QTY	MATERIAL	REMARK
1	SHELL	1PCS	STAINLESS	NICKEL PLATED 50u" MIN. OVER ALL
2	INSERT HOUSING	1PCS	LCP	UL94V-0
3	Mid-PLATE	1PCS	STAINLESS	NI PLATED 50u" MIN. OVER ALL
4	TOP CONTACT	1SET	COPPER ALLOY	SEE NOTES
5	BOTTOM CONTACT	1SET	COPPER ALLOY	
6	RUBBER RING	1PCS	SILICA GEL	BLACK



THIS DOCUMENT IS THE SOLE PROPERTY OF BBJconn Technology Co.,Ltd. Corporation AND SHOULD NOT BE USED IN WHOLE OR IN PART WITHOUT PRIOR WRITTEN PERMISSION. PDWG,NO: 9999-9

深圳市步步精科技有限公司

NAME: TYPE-C 16P 母座 L=6.5 CH1.73 板上型 四脚插 全框 DIP (WP 8) 压铸壳

PJ. NO.: UC.01.11-1N-0019
SIZE: A4 DRW NO.: CC23-0001

FINISH: SEE NOTES MAT'L.: SEE NOTES
SCALE: N/A REV.: A2 UNIT: mm PAGE: 1/3

APPD. JM_Zheng
CHKD. DAX
DR. DAX

尺寸公差: .X: ±0.28 .XX: ±0.18 .XXX: ±0.08
X': ±3' .X': ±1' .XX': ±1'

REV.	ECN NO.	CONTENT	DATE	ENGINEER
A0		Initial release	2023 07/21	JM_Zheng
A1	EN2308014	外壳边缘由3.86改为4.36	2023 08/23	JM_Zheng
A2	EN2312003	Nylon改为LCP	2023 12/13	JM_Zheng

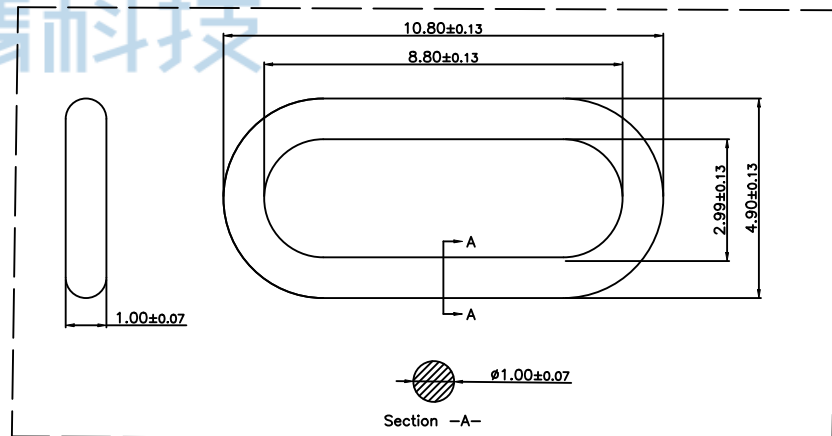
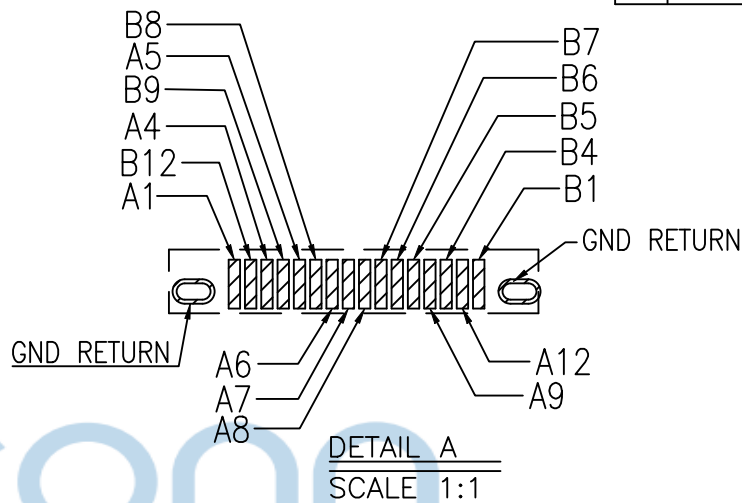
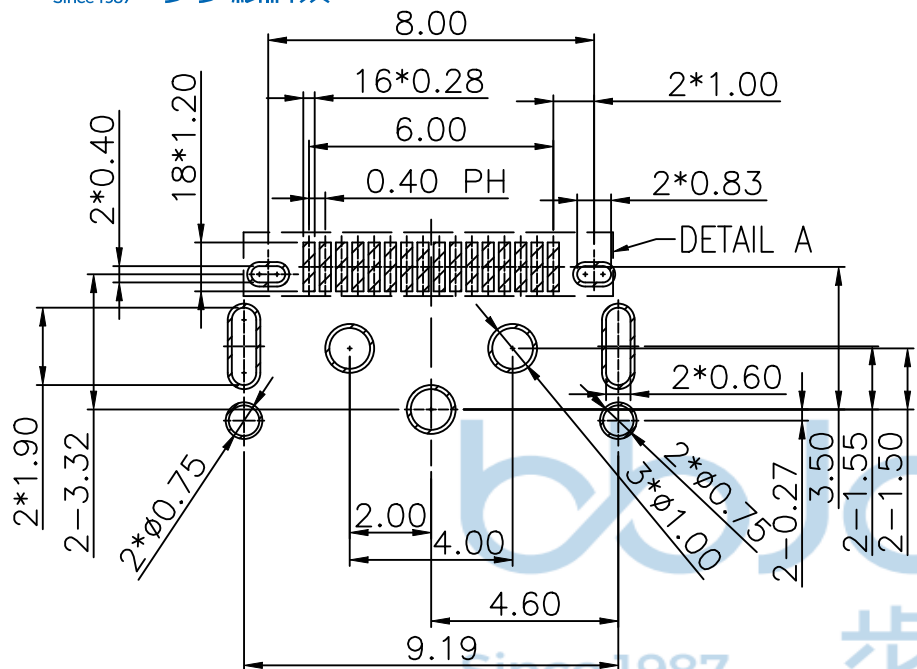

RECOMMENDED PCB LAYOUT
GENERAL TOLERANCE ± 0.05



THIS DOCUMENT IS THE SOLE PROPERTY OF BBJconn Technology Co.,Ltd. Corporation AND SHOULD NOT BE USED IN WHOLE OR IN PART WITHOUT PRIOR WRITTEN PERMISSION. PDWG.NO: 9999-9	深圳市步步精科技有限公司		NAME: TYPE-C 16P 母座 L=6.5 CH1.73 板上 型 四脚插 全框 DIP (WP 8) 压铸壳	
	.X: ± 0.28 .XX: ± 0.18 .XXX: ± 0.08	X': $\pm 3^*$.X': $\pm 1^*$.XX': $\pm 1^*$	APPD. JM_Zheng CHKD. DAX DR. DAX	PJ. NO.: UC.01.11-1N-0019 SIZE: A4 DRW NO.: CC23-0001 FINISH: SEE NOTES SCALE: N/A

REV.	ECN NO.	CONTENT	DATE	ENGINEER
AO		Initial release	2023 07/21	LYX
A1	EN2308014	外壳边缘由3.86改为4.36	2023 08/23	JM_Zheng
A2	EN2312003	Nylon改为LCP	2023 12/13	JM_Zheng

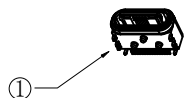
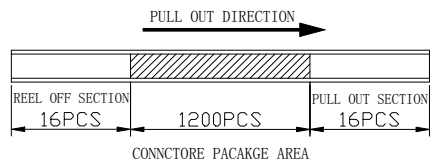

出料方向

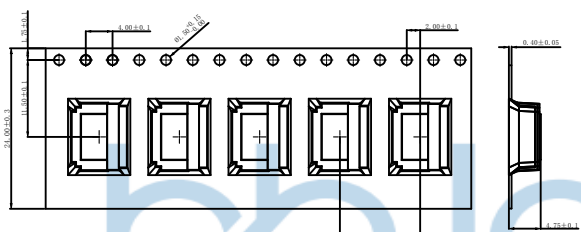

PULL OUT DIRECTION

PEELING SPEED 200mm/Min

COVER TYPE PEELING FORCE:

A	165° ~ 180°
F	0.1N ~ 1.3N

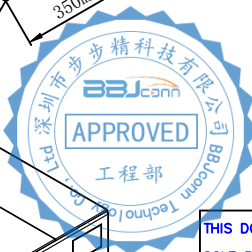
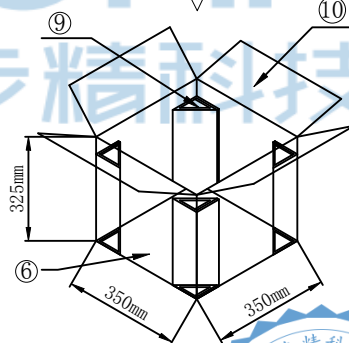
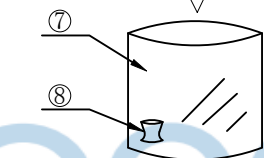
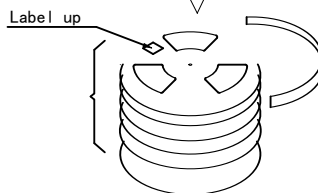
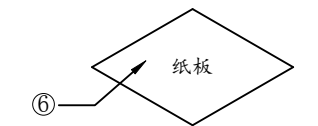
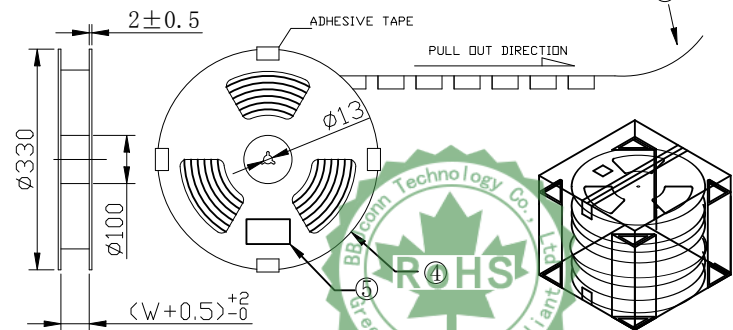

1. 包装方式:

- 1.1 使用半自动包装机, 先将CARRY TAPE 送入导轨中, 并与COVER TAPE 贴合在上面, 将产品如图所示方向依次放入CARRY TAPE内, 每REEL共包装产品见下表
- 1.2 用胶带将CARRY TAPE粘在一起, 外围再用塑胶带缠绕一圈, 按客户要求REEL 贴上LABEL, 注明料号, 日期, 数量.
- 1.3 如图示, 将装好的REEL装入PE袋内, PE袋内放置2Pcs干燥剂, 然后在外箱底部放1Pcs纸板, 纸箱内4个角分别放置1个三角板, 再将PE袋内REEL放入纸箱内, 顶部再加盖一个纸板, 最后用胶带封箱, 并在纸箱外相应的地方贴上标签.
- 1.4 包装数量: 见下表

⑪	LABEL (CARTON) 纸箱标签	1Pcs	80mm*50mm
⑩	CARTON (纸箱)	1Pcs	L350*W350*H325 (内尺寸)
⑨	FOLDER PAPER BOARD (护角)	4Pcs	(85+85+85+85) *310
⑧	DESICCANT (干燥剂)	2Pcs	
⑦	PE Bag (PE袋)	1Pcs	520*320*460, T=0.05mm
⑥	PAPER BOARD (纸板)	2Pcs	(85+85+85+85) *310
⑤	LABEL (TAPE REEL) 标签	10Pcs	80mm*50mm
④	REEL (卷轴)	10R	Ø330mm, H=24.5mm
③	COVER TAPE (盖带)	1R	PET, W=21.3mm
②	TAPE REEL (载带)	10Pcs	PET, W=24mm, T=0.5mm, 总长9.4M
①	产品总数	12000Pcs	N/A
NO.	DESCRIPTION	QTY	MATERIAL

THIS DOCUMENT IS THE SOLE PROPERTY OF BBJconn Technology Co., Ltd. CORPORATION AND SHOULD NOT BE USED IN WHOLE OR IN PART WITHOUT PRIOR WRITTEN PERMISSION.
PDWG.NO: 9999-9

深圳市步步精科技有限公司

.X: ±0.38 X': ±3'
.XX: ±0.25 .X': ±2'
.XXX: ±0.13 .XX': ±1'

NAME: TYPE-C 16P 母座 L=6.5 CH1.73 板上型 四脚插 全框 DIP (WP 8) 压铸壳

APPD. JM_Zheng

PJ. NO.: UC.01.11-1N-0019

CHKD. HongGuang

SIZE: A4 DRW NO.: CC23-0001

DR. LYX

FINISH: SEE NOTES MAT'L.: SEE NOTES

SCALE: N/A REV.: A2 UNIT: mm PAGE: 3/3