

REV.	ECN NO	CONTENT	DATE	ENGINEER
A0		Initial release	/	LYL

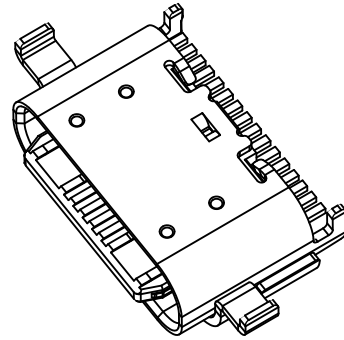

SPECIFICATION:

- ELECTRICAL CHARACTERISTICS:
  - CURRENT RATING: 5A
  - TEMPERATURE RANGE: -40 °C ~ 85 °C
  - CONTACT RESISTANCE: 30 MILLIONHM MAX.
  - DIELECTRIC WITHSTANDING VOLTAGE: 100 VAC r.m.s
  - INSULATION RESISTANCE: 100 MEGOHMS MIN.
- MECHANICAL CHARACTERISTICS
  - INSERTION FORCE: 5~20N
  - EXTRACTION FORCE: Initial:8~20N,ATER TEST 6~20N
  - DURABILITY:10,000CYCLES
- THE SHELL LENTH IS LESS THAN THE MINIMUM SPECIFIED BY THE USB TYPE C STANDARD.AS SUCH IS CONNOT INDENOENDENTLY BE GUARANTEED TO MEET ALL TYPE C MECHANICAL REQUIREMENTS.

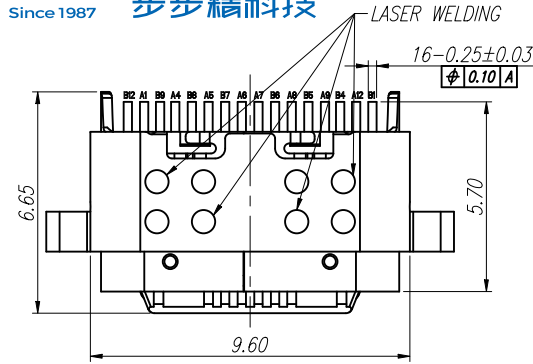
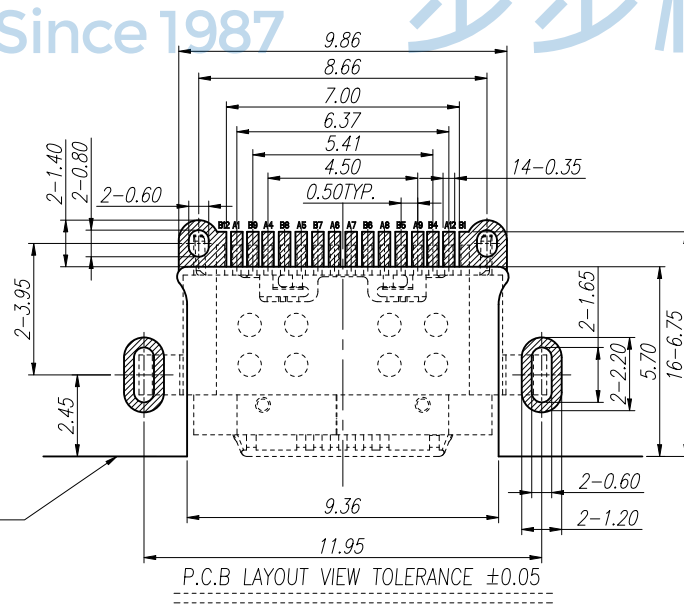
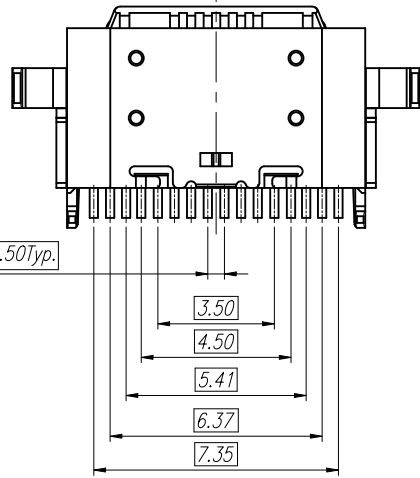
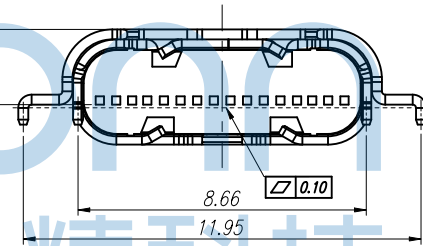
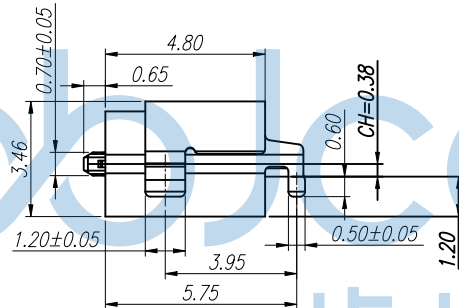
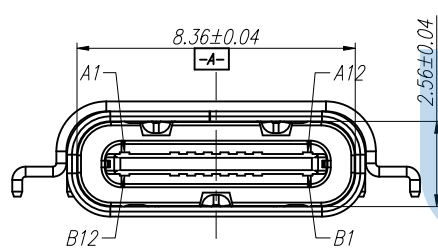

PIN ASSIGNMENT												BLADE	SHELL
A1	A2	A3	A4	A5	A6	A7	A8	A9	A10	A11	A12		
GND	TX1+	TX1-	VBUS	CC1	D+	D-	SBU1	VBUS	RX2-	RX2+	GND		
GND	RX1+	RX1-	VBUS	SBU2	D-	D+	CC2	VBUS	TX2-	TX2+	GND	GND	GND
B12	B11	B10	B9	B8	B7	B6	B5	B4	B3	B2	B1		

NO.	DESCRIPTION	QTY.	MATERIAL	FINISHED
5	MID PLATE	1 PCS	SUS301 T=0.15	None
4	CONTACT 2	1 SET	C7025 T=0.15	Ni 50~100u" Plated; After Au 1u" Plated On Contact Area And Solder Area
3	CONTACT 1	1 SET	C7025 T=0.15	
2	IM HOUSING	1 PCS	PA46 BLACK UL94V-0	None
1	SHELL	1 PCS	SUS304 T=0.30	Ni 50~120u" Plated

THIS DOCUMENT IS THE SOLE PROPERTY OF BBJconn Technology Co.,Ltd. Corporation AND SHOULD NOT BE USED IN WHOLE OR IN PART WITHOUT PRIOR WRITTEN PERMISSION.

PDWG:NO: 0851-1

**深圳市步步精科技有限公司**

NAME: TYPE-C 16P 母座 双壳 四脚插 端子SMT 舌片外漏0.65 沉板1.20 L=4.80 CH=0.38 编带

APPD. JM\_Zheng

CHKD. LYX

DR. LYL

PJ. NO.: 126-221-160013-M3G

SIZE: A4 DRW NO.:

FINISH: SEE NOTES MAT'L.: SEE NOTES

SCALE: N/A REV.: A0 UNIT: mm PAGE: 1/2

REV.	ECN NO	CONTENT	DATE	ENGINEER
AO		Initial release	/	LYL

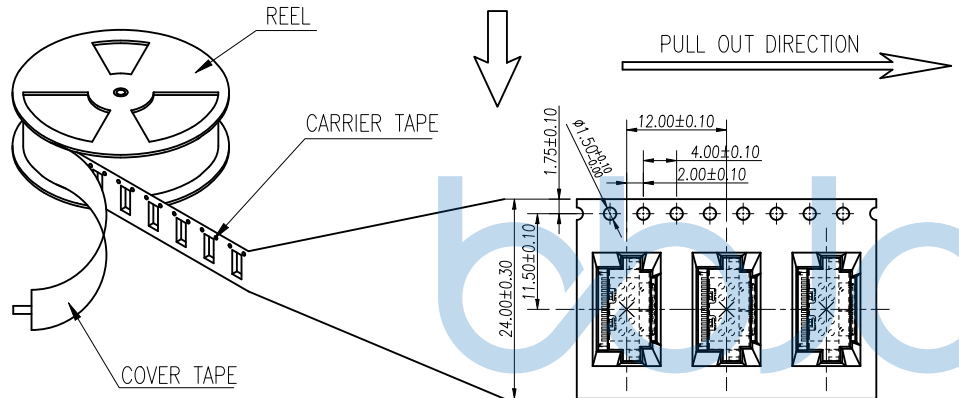
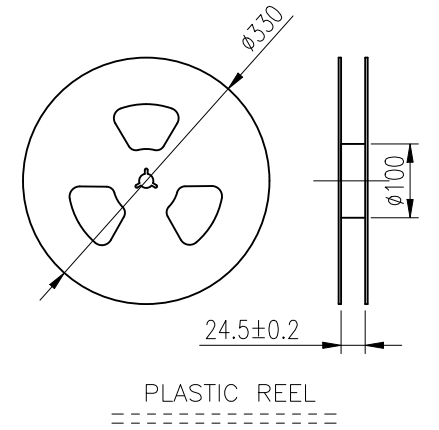
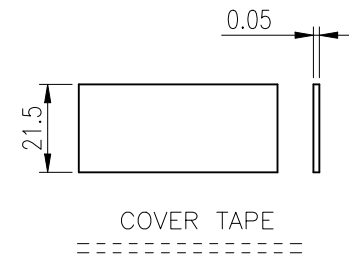
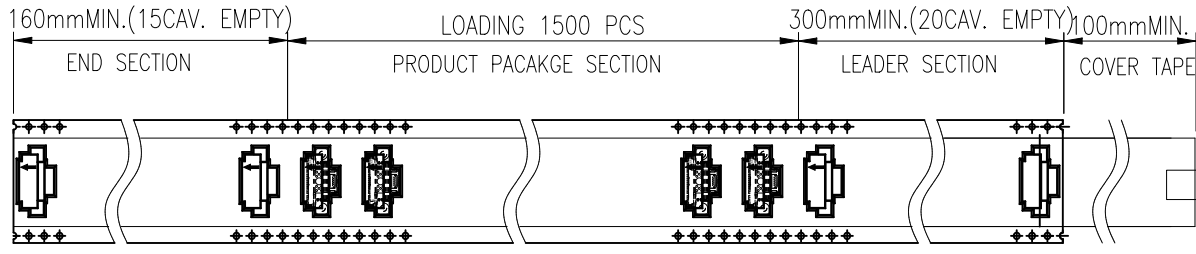

- NOTES 2:
- MATERIAL:
    - 1.1 REEL AND AXLE: PS,BLUE
    - 1.2 CARRIER TAPE: PET, LUCID
    - 1.3 COVER TAPE: PS,TRANSPARENT
    - 1.4 SHIPPING CARTON: CORRUGATED FIBER
  - DIMENSION:
    - 2.1 REEL: W=24.5, φA=330
    - 2.2 CARRIER TAPE: T=0.50 W=24.0
    - 2.3 COVER TAPE: T=0.05 W=21.3
    - 2.4 SHIPPING CARTON: L=335mm, W=335mm, H=425mm
  - QUANTITY:
    - 3.1 PRIMAY PACKING: 1500PCS/REEL
    - 3.2 SECONARY PACKING: 12 REELS/CARTON(18000PCS/CARTON)
  - PEELING RESISTANCE: 0.1~1.3N
    - 4.1 PEELING SPEED: 300mm/minutes
    - 4.2 PEELING ANGLE: 165°~180°

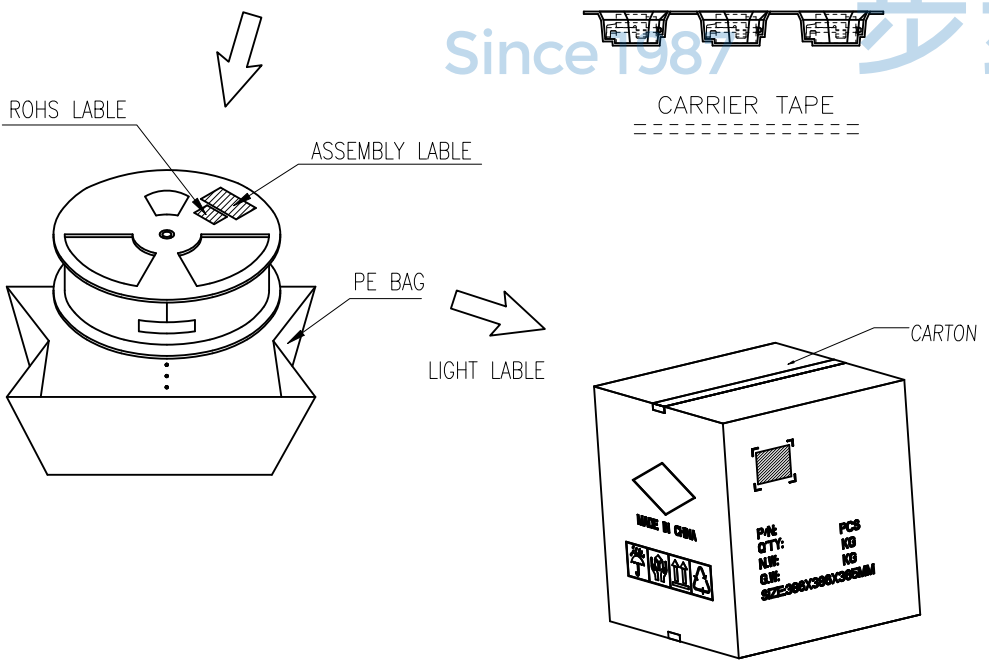

THIS DOCUMENT IS THE SOLE PROPERTY OF BBJconn Technology Co.,Ltd. Corporation AND SHOULD NOT BE USED IN WHOLE OR IN PART WITHOUT PRIOR WRITTEN PERMISSION.		<b>深圳市步步精科技有限公司</b>	
.X: ±0.38 .XX: ±0.25 .XXX: ±0.13		X': ±3' X'': ±2' XX': ±1'	
NAME: TYPE-C 16P 母座 双壳 四脚插 端子SMT 舌片外漏0.65 沉板1.20 L=4.80 CH=0.38 编带		PJ. NO.: 126-221-160013-M3G	
APPD. JM_Zheng	SIZE: A4		DRW NO.:
CHKD. LYX	FINISH: SEE NOTES		MAT'L.: SEE NOTES
DR. LYL	SCALE: N/A	REV.: AO	UNIT: mm
PDWG.NO: 0851-1	PAGE: 2/2		