

REV.	ECN NO	CONTENT	DATE	ENGINEER
A0		Initial release	/	LYL

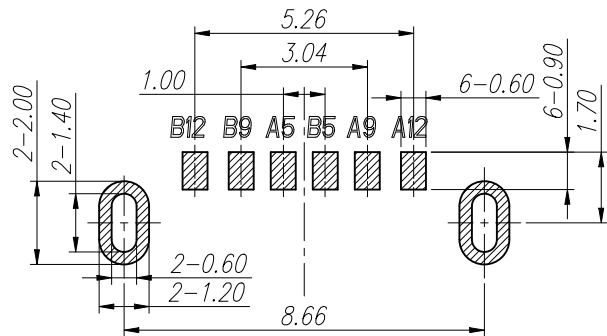
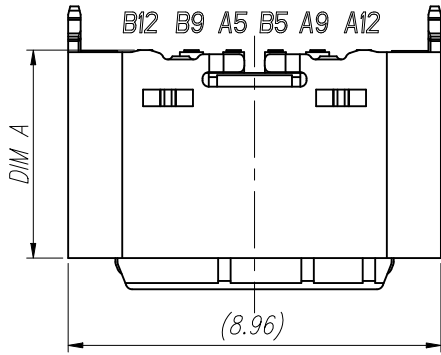

P.C.B LAYOUT VIEW

TOLERANCE  $\pm 0.05$

SPECIFICATION:

1.ELECTRICAL CHARACTERISTICS:

- 1.1 CURRENT RATING: 3A
- 1.2 TEMPERATURE RANGE:  $-40^{\circ}\text{C} \sim 85^{\circ}\text{C}$
- 1.3 CONTACT RESISTANCE: 30 MILLIONHM MAX.
- 1.4 DIELECTRIC WITHSTANDING VOLTAGE: 100 VAC r.m.s
- 1.5 INSULATION RESISTNACE: 100 MEGOHMS MIN.

2.MECHANICAL CHARACTERISTICS

- 2.1 INSERTION FORCE: 5~20N
- 2.2 EXTRACTION FORCE: Initial:8~20N,ATER TEST 6~20N
- 2.3 DURABILITY:10,000CYCLES

3.THE SHELL LENTH IS LESS THAN THE MINIMUM SPECIFIED BY THE USB TYPE C STANDARD,AS SUCH IS CONNOT INDENOENDENTLY BE GUARANTEED TO MEET ALL TYPE C MECHANICAL REQUIREMENTS.

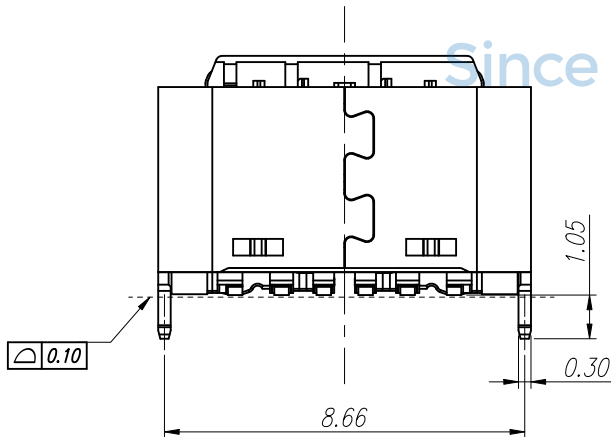
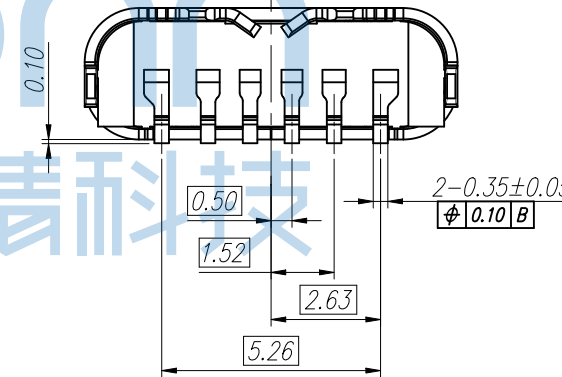
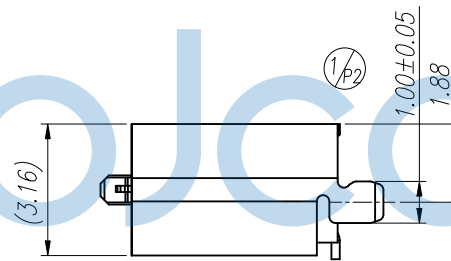
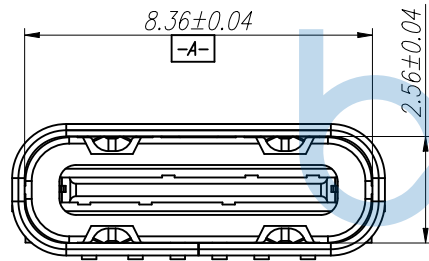

TABLE 1

DIM A	DIM B
5.00	6.25
5.50	6.50
6.00	7.00
6.80	7.80
6.50	7.50

PIN ASSIGNMENT

A1	A2	A3	A4	A5	A6	A7	A8	A9	A10	A11	A12	BLADE	SHELL
GND	TX1+	TX1-	VBUS	CC1	D+	D-	SBU1	VBUS	RX2-	RX2+	GND		
GND	RX1+	RX1-	VBUS	SBU2	D-	D+	CC2	VBUS	TX2-	TX2+	GND	GND	GND
B12	B11	B10	B9	B8	B7	B6	B5	B4	B3	B2	B1		

THIS DOCUMENT IS THE SOLE PROPERTY OF **深圳市步步精科技有限公司** (BBJconn Technology Co., Ltd.) CORPORATION AND SHOULD NOT BE USED IN WHOLE OR IN PART WITHOUT PRIOR WRITTEN PERMISSION.

APPD. JM\_Zheng  
CHKD. LYX  
DR. LYL

NAME: TYPE-C 6P 母座 直立式 两脚插 端子SMT H=5.0 舌片外漏0.75 加盖编带

PJ. NO.: 126-224-060003-M3G  
SIZE: A4 DRW NO.:  
FINISH: SEE NOTES MAT'L.: SEE NOTES

SCALE: N/A REV.: A0 UNIT: mm PAGE: 1/3

REV.	ECN NO	CONTENT	DATE	ENGINEER
A0		Initial release	/	LYL

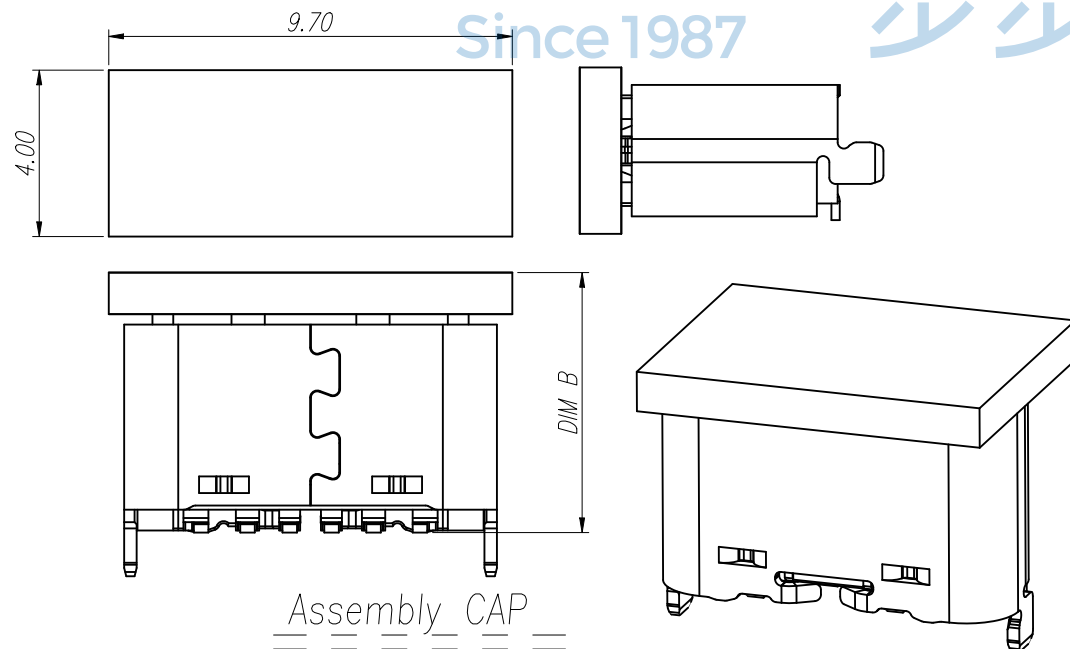
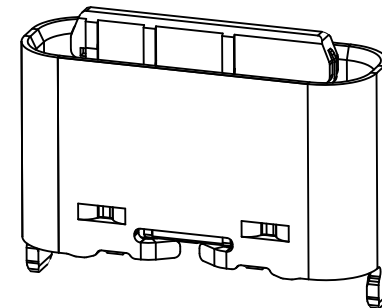
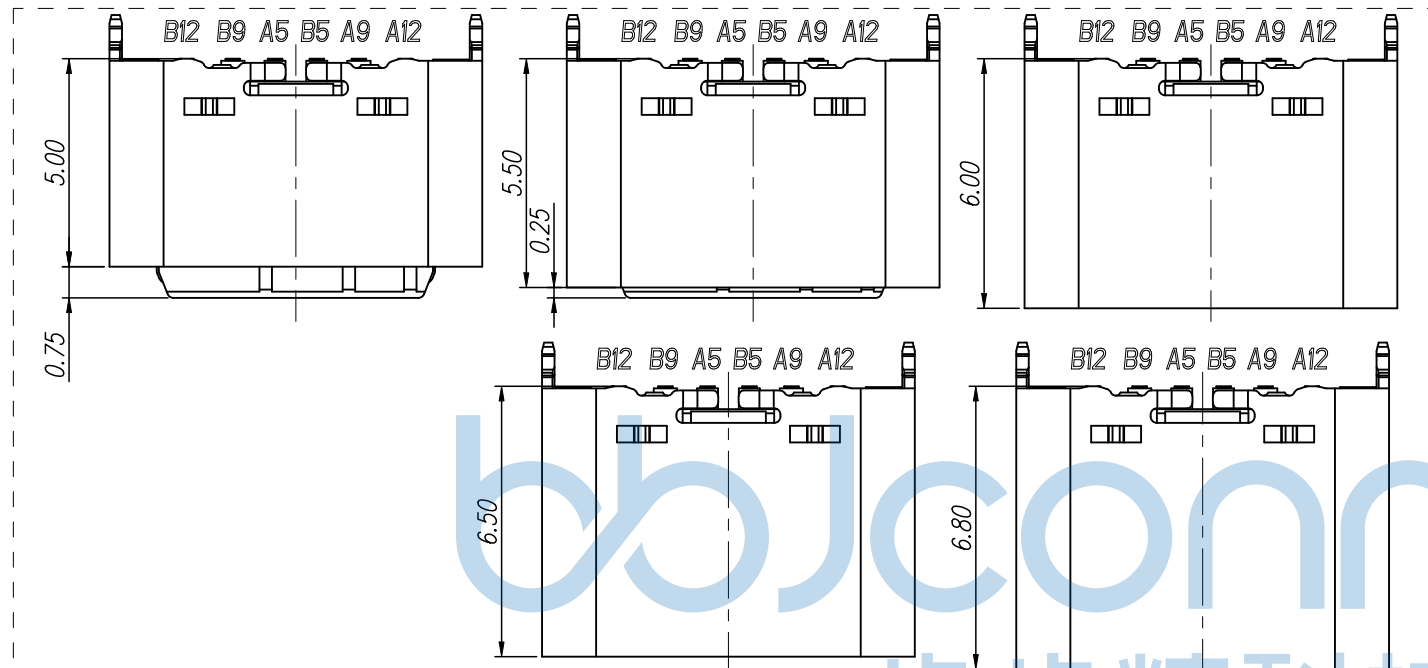

4	MID PLATE	1 PCS	SUS301	None
3	CONTACT	1 SET	C2680	Ni 50~100u" Plated; After Au G/F Plated On Contact Area And Solder Area
2	IM HOUSING	1 PCS	LCP BLACK UL94V-0	None
1	SHELL	1 PCS	SUS201	Ni 50~120u" Plated
NO.	DESCRIPTION	QTY.	MATERIAL	FINISHED

THIS DOCUMENT IS THE SOLE PROPERTY OF BBJconn Technology Co.,Ltd. Corporation AND SHOULD NOT BE USED IN WHOLE OR IN PART WITHOUT PRIOR WRITTEN PERMISSION.		深圳市步步精科技有限公司 .X: ±0.38    .X': ±3" .XX: ±0.25    .X'': ±2" .XXX: ±0.13    .XX': ±1"		NAME: TYPE-C 6P 母座 直立式 两脚插 端子SMT H=5.0 舌片外漏0.75 加盖编带	
APPD.	JM_Zheng	PJ. NO.: 126-224-060003-M3G		SIZE: A4   DRW NO.:	
CHKD.	LYX	FINISH: SEE NOTES		MAT'L.: SEE NOTES	
PDWG.NO:	0851-1	DR.	LYL	SCALE: N/A	REV.: A0   UNIT: mm   PAGE: 2/3

REV.	ECN NO	CONTENT	DATE	ENGINEER
AO		Initial release	/	LYL

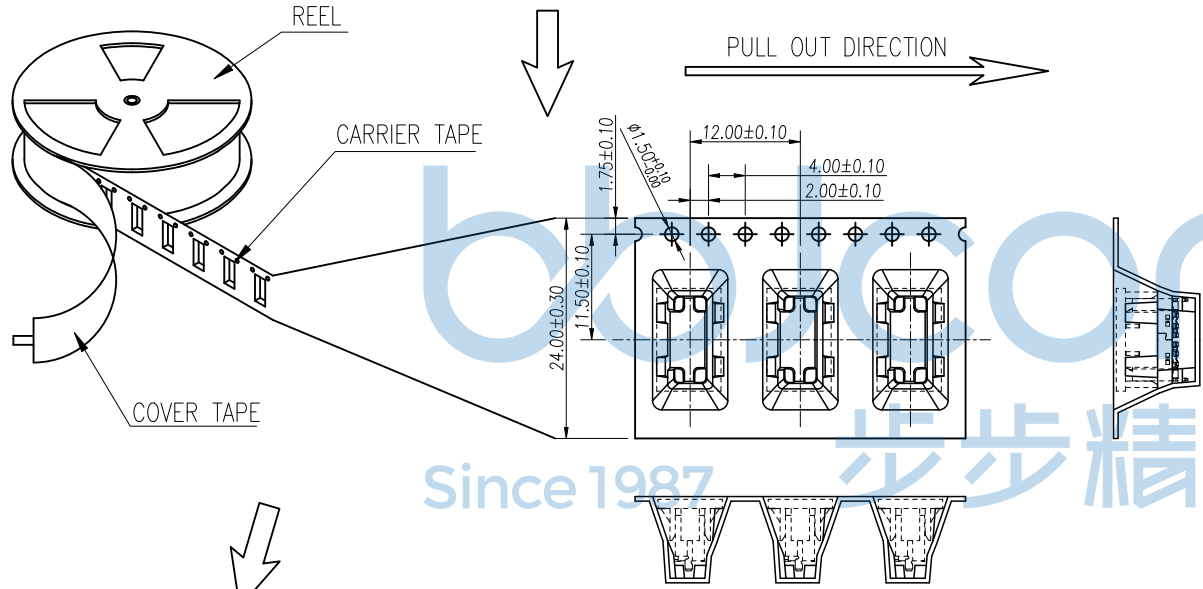
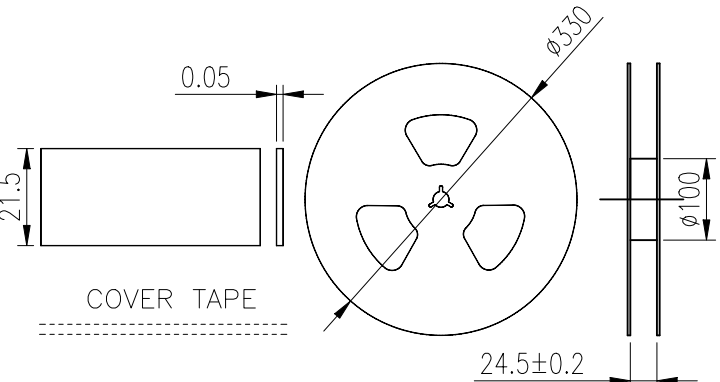
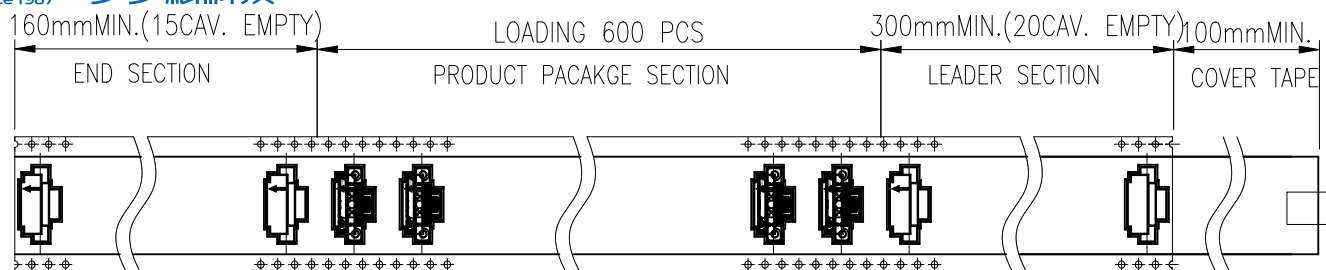

- NOTES 2:
- MATERIAL:
    - 1.1 REEL AND AXLE: PS,BLUE
    - 1.2 CARRIER TAPE: PET, LUCID
    - 1.3 COVER TAPE: PS,TRANSPARENT
    - 1.4 SHIPPING CARTON: CORRUGATED FIBER
  - DIMENSION:
    - 2.1 REEL: W=24.5,  $\phi$ A=330
    - 2.2 CARRIER TAPE: T=0.50 W=24.0
    - 2.3 COVER TAPE: T=0.05 W=21.5
    - 2.4 SHIPPING CARTON: L=335mm, W=335mm, H=365mm
  - QUANTITY :
    - 3.1 PRIMAY PACKING: 600 PCS/REEL
    - 3.2 SECONARY PACKING: 12 REELS/CARTON(7200PCS/CARTON)
  - PEELING RESISTANCE: 0.1~1.3N
    - 4.1 PEELING SPEED: 300mm/minutes
    - 4.2 PEELING ANGLE: 165° ~180°

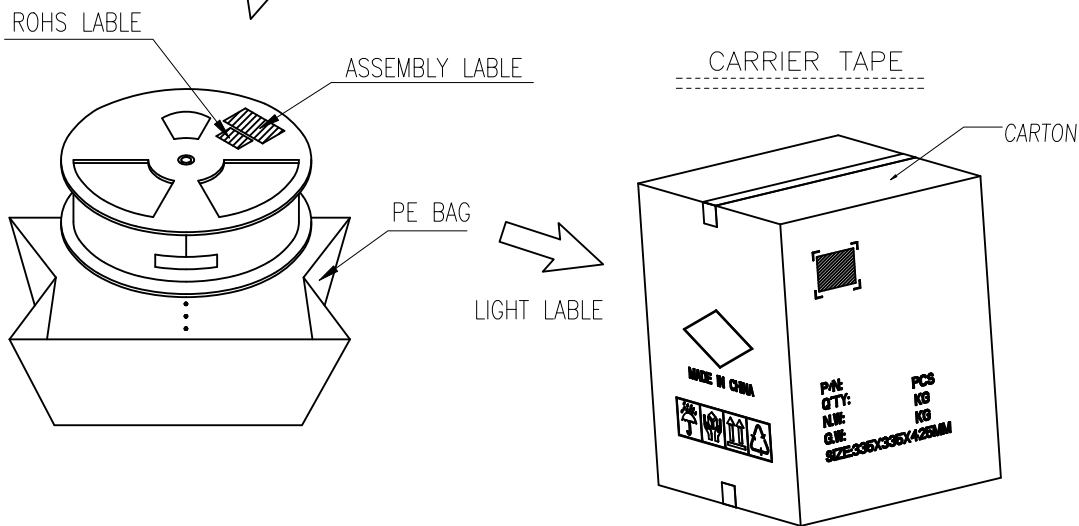

THIS DOCUMENT IS THE SOLE PROPERTY OF BBJconn Technology Co.,Ltd. Corporation AND SHOULD NOT BE USED IN WHOLE OR IN PART WITHOUT PRIOR WRITTEN PERMISSION.		<b>深圳市步步精科技有限公司</b> 工程 部 APPROVED		NAME: TYPE-C 6P 母座 直立式 两脚插 端子SMT H=5.0 舌片外漏0.75 加盖编带	
.X: ±0.38    .X': ±3' .XX: ±0.25    .X'': ±2' .XXX: ±0.13    .X''': ±1'		APPD. JM_Zheng CHKD. LYX DR. LYL		PJ. NO.: 126-224-060003-M3G SIZE: A4   DRW NO.: FINISH: SEE NOTES    MAT'L.: SEE NOTES	
PDWG.NO: 0851-1		SCALE: N/A		REV.: AO    UNIT: mm    PAGE: 3/3	