

RECOMMENDED P.C.B. LAYOUT  
TOLERANCE UNSPECIFIED ±0.05mm

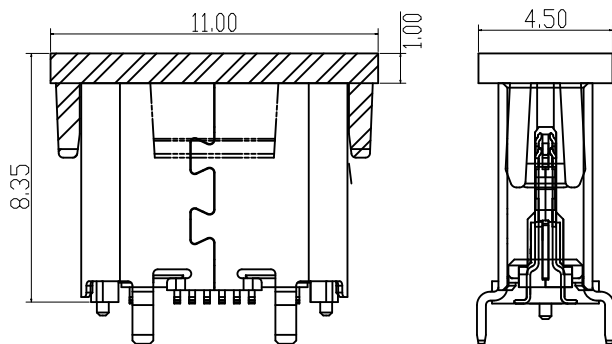

装吸取盖示意图

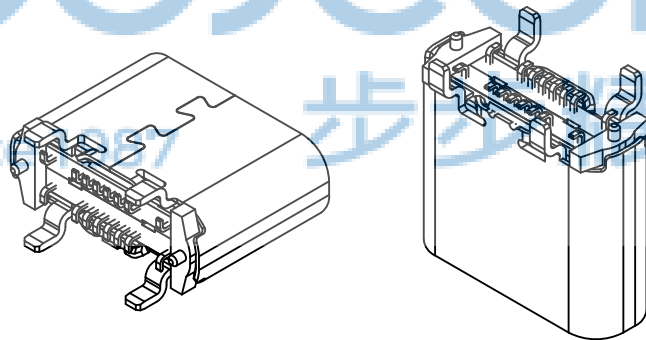
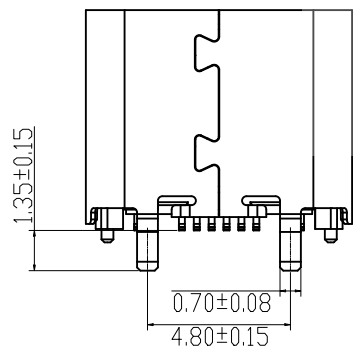
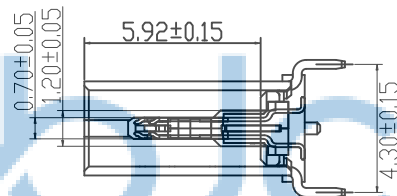
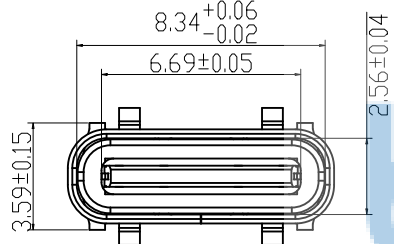
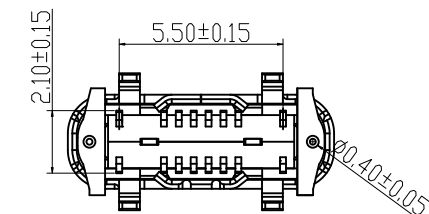

REV.	ECN NO	CONTENT	DATE	ENGINEER
AO				

备注:

- 材质:
  - 1.1 胶芯: LCP+30%G.F UL94V-0
  - 1.2 端子: 高导电C7025, T=0.15mm; 镍底50U" MIN, 接触区域镀金 (AU 1u") 焊接区镀金G/F
  - 1.3 外壳: SUS304, T=0.30mm; 表面镀镍50U" MIN
  - 1.4 中夹片: SUS301, T=0.15mm;
- 主要特性:
  - 2.1 额定电流: 5A
  - 2.2 接触阻抗: 40mΩ MAX (初始值)  
50mΩ MAX (测试后)
  - 2.3 绝缘阻抗: 100MΩ MIN
  - 2.4 耐压测试: 100V AC R. M. S.
  - 2.5 整体插入力: 5-20N 整体插入力: 5-20N (耐久后)  
整体拔出力: 8-20N 整体拔出力: 6-20N (耐久后)
  - 2.7 耐久: 10000次
  - 2.8 耐高温: SMT回流焊 (峰值260° ±5°), 塑胶不能有起泡, 融胶等不良, 变色, 翘曲变形在公差范围内;
  - 2.9 产品须做焊锡测试, 粘锡面积达到95%以上;
  - 3.0 盐雾测试: 48H MIN
  - 3.1 工作温度: -30°C ~+85°C



USB TYPE-C PIN ASSIGNMENTS

PIN NUMBER	A1	A2	A3	A4	A5	A6	A7	A8	A9	A10	A11	A12
SIGNAL NAME	GND			Vbus	CC1	Dp1	Dn1	SBU1	Vbus			GND
PIN NUMBER	B12	B11	B10	B9	B8	B7	B6	B5	B4	B3	B2	B1
SIGNAL NAME	GND			Vbus	SBU2	Dn2	Dp2	CC2	Vbus			GND

THIS DOCUMENT IS THE  
SOLE PROPERTY OF  
BBJconn Technology Co.,Ltd.  
Corporation AND SHOULD  
NOT BE USED IN WHOLE  
OR IN PART WITHOUT  
PRIOR WRITTEN PERMISSION.

深圳市步步精科技有限公司

.X: ±0.38 X': ±3"  
.XX: ±0.25 .X': ±2"  
.XXX: ±0.13 .XX': ±1"

NAME: TYPE-C 16P 母座 直立式 四脚插  
带柱 端子SMT H=7.40

APPD. JM\_Zheng

PJ. NO.: UC.01.61-1W-0025

CHKD. LYX

SIZE: A4 DRW NO.:

PDWG.NO: 0482-1 DR. TSP

FINISH: SEE NOTES MAT'L.: SEE NOTES

SCALE: N/A REV.: AO UNIT: mm PAGE: 1/2

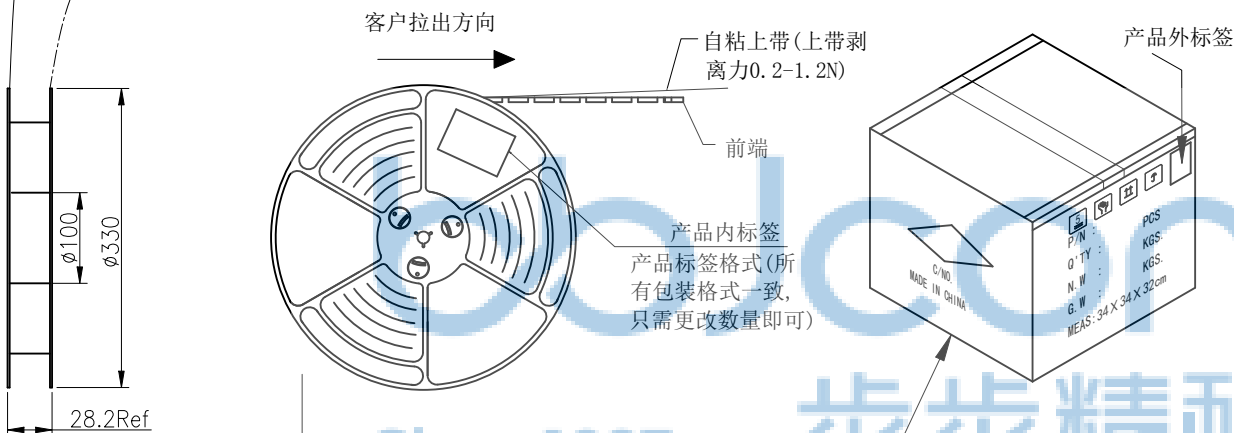
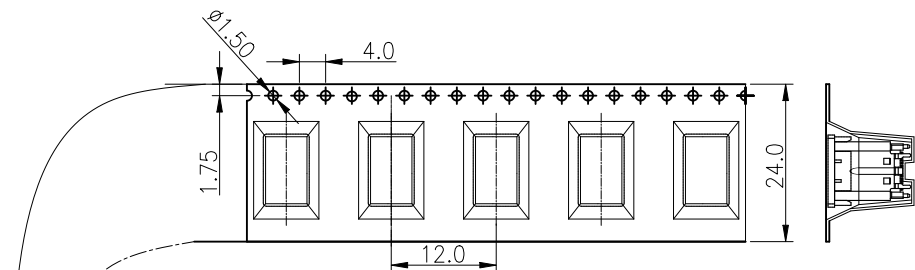

备注:

1. 把上下载带送入载带机进行调整, 然后将产品按照指定的方式摆入下载带中, 开动卷带机进行卷装 (每卷包600PCS), 卷装完成后需用上带缠绕最少20CM;
2. 在卷装OK的每卷盘面的指定位置上贴上物料和RoHS标签装入纸箱内; 每箱装10盘
3. 纸箱用封箱带将其封好, 胶带要求工字型, 不可遮住标签;
4. 如果客户对包装标签另有要求, 请按客户要求作业; 有未满足之零数箱需用缓冲材料填充;
5. 上载带剥离力:0.2-1.2N.;

包装示意图:

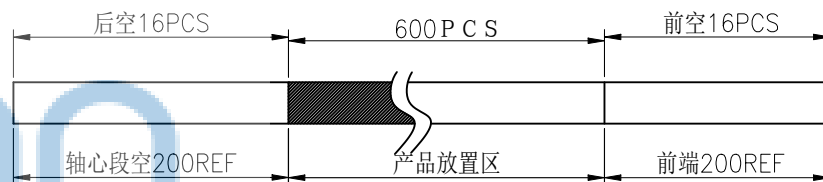

卷带盘10盘

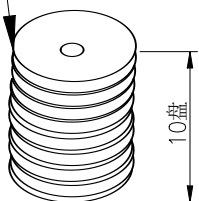

将10盘产品放入纸箱内

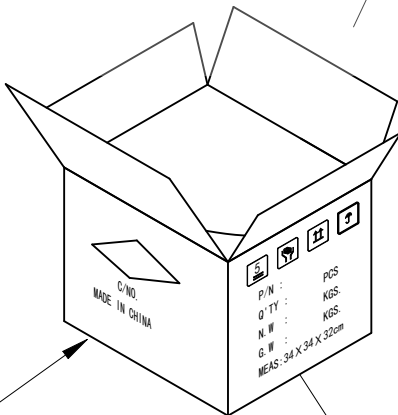

纸箱规格:  
34.0X34.0X32CM



THIS DOCUMENT IS THE SOLE PROPERTY OF BBJconn Technology Co.,Ltd. Corporation AND SHOULD NOT BE USED IN WHOLE OR IN PART WITHOUT PRIOR WRITTEN PERMISSION.		<b>深圳市步步精科技有限公司</b>	
PDWG:NO: 0482-1	DR. TSP	.X: ±0.38 .XX: ±0.25 .XXX: ±0.13 X': ±3' .X': ±2' XX': ±1'	NAME: TYPE-C 16P 母座 直立式 四脚插 带柱 端子SMT H=7.40 APPD. JM_Zheng CHKD. LYX PJ. NO.: UC.01.61-1W-0025 SIZE: A4 DRW NO.: FINISH: SEE NOTES MAT'L.: SEE NOTES SCALE: N/A REV.: AO UNIT: mm PAGE: 2/2