

REV.	ECN NO	CONTENT	DATE	ENGINEER
A0		Initial release	/	LYL

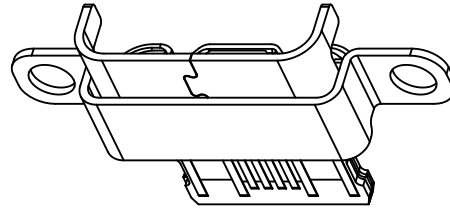

3D VIEW

- SPECIFICATION:
- Material & Finish: See the list;
  - Mechanical:
    - Mating force: 5-20N;
    - Unmating force: Initial: 8-20N; Final: 6-20N;
    - Durability: 10000 Cycles;
  - Electrical:
    - Current Rating:
      - VBus Pins: 3A, Vconn Pin: 1.25A, Other Pins: 0.25A;
    - Voltage Rating: 30V Max.;
    - Dielectric Withstanding voltage: 100Vac, 60S, 10mA;
    - Contact resistance: 40m Ohms Max.;
    - Insulation Resistance: 100M Ohms Min.;
  - Environmental:
    - Operating temperature: -40° C ~ +85° C;
    - Salt Spray Test: 48H Min. (No oxidation or rust);
    - Wetting Temperature: 265 ± 5° C, 5 ± 0.5s

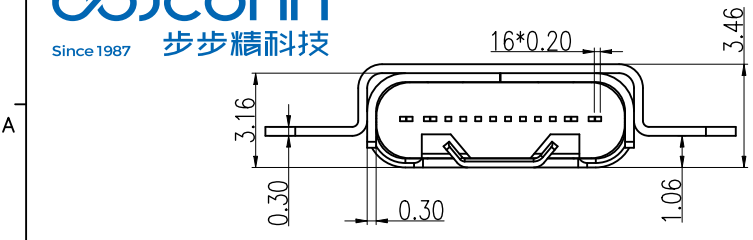
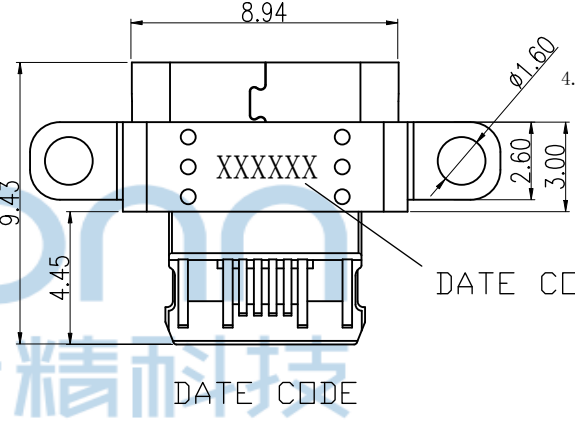
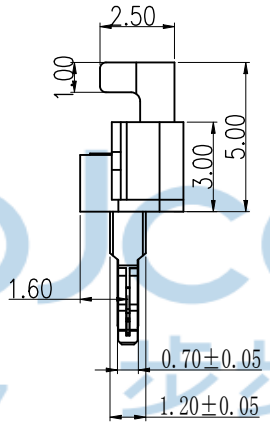
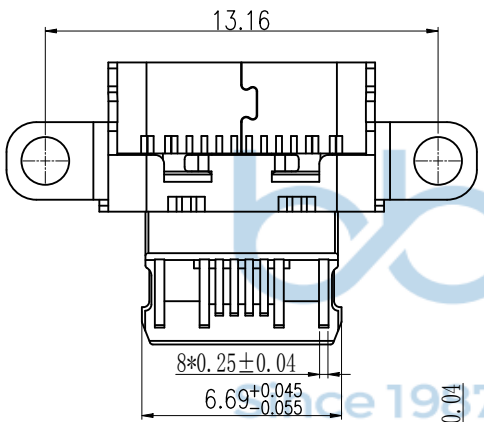
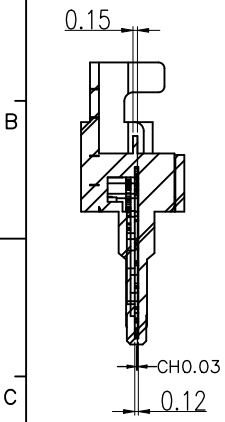

DATE CODE

DATE CODE

XX XX XX

Day: 07-7号  
Month: 10-10月  
Year: 23-2023年  
(字体: 宋体; 字高: 0.8)

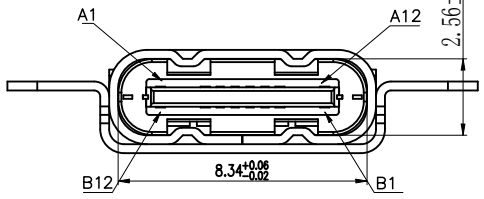

PIN	SIGNAL	PIN	SIGNAL
A12	GND	B1	GND
A11		B2	
A10		B3	
A9	VBUS	B4	VBUS
A8	SBU1	B5	CC2
A7	Dn1	B6	Dp2
A6	Dp1	B7	Dn2
A5	CC1	B8	SBU2
A4	VBUS	B9	VBUS
A3		B10	
A2		B11	
A1	GND	B12	GND



5	外烧印	SUS304 T=0.30mm	Ni 50u" Min Plated	1PCS	48H	Reel
4	烧胶	SUS304 T=0.30mm	Ni 50u" Min Plated	1PCS		
3	冲壳	SUS301-H T=0.12mm	NO PLATED	1PCS		
2	料	C2680 T=0.15mm	Au 1u" PLATING ON CONTACT AREA; TIN 50u" Min TING ON SOLDER TAIL; NI 50u" Min UNDERPLATING OVERALL	1SET		
1	HOUSING	PA46	BLACK	1PCS		
NO.	DESCRIPTION	MATERIAL	REMARKS	QTY	盐雾	PACKAGING

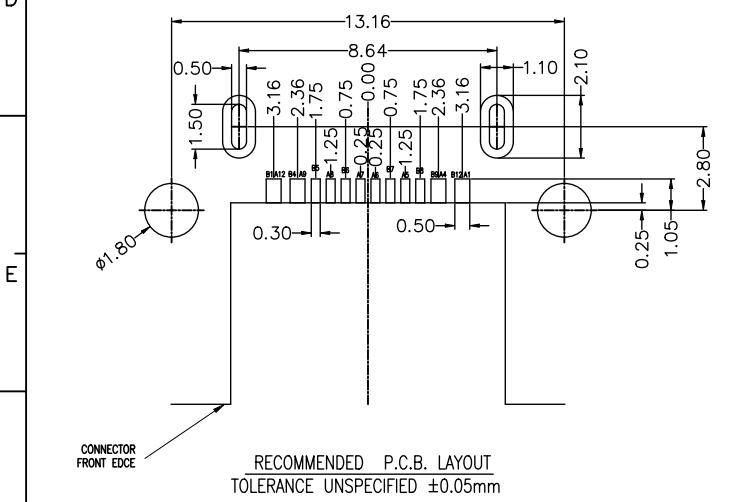

THIS DOCUMENT IS THE SOLE PROPERTY OF **深圳市步步精科技有限公司** BBJconn Technology Co., Ltd.

Corporation AND SHOULD NOT BE USED IN WHOLE OR IN PART WITHOUT PRIOR WRITTEN PERMISSION.

PDWG.NO: 0541-1

NAME: TYPE-C 16P 母座 L=9.45 CH0.03 沉板1.6 带马甲 端子SMT

APPD. JM\_Zheng

CHKD. LYX

DR. LYL

PJ. NO.: 126-221-160001-X7G

SIZE: A4 DRW NO.:

FINISH: SEE NOTES MAT'L.: SEE NOTES

SCALE: N/A REV.: A0 UNIT: mm PAGE: 1/2

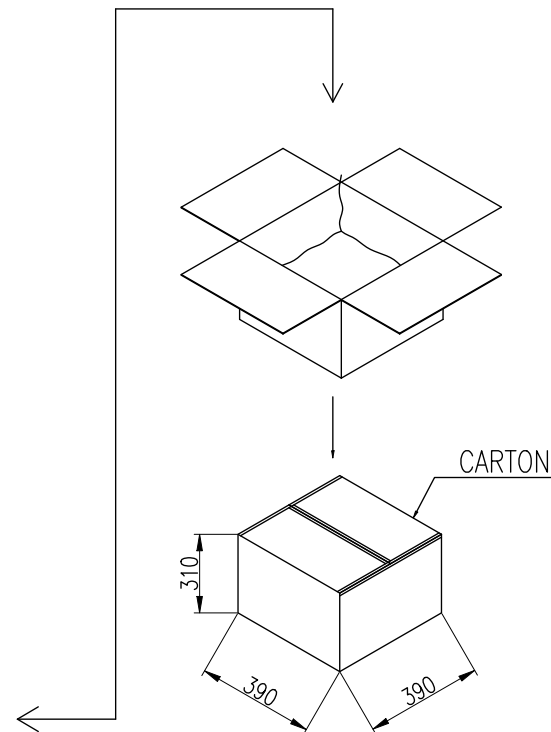
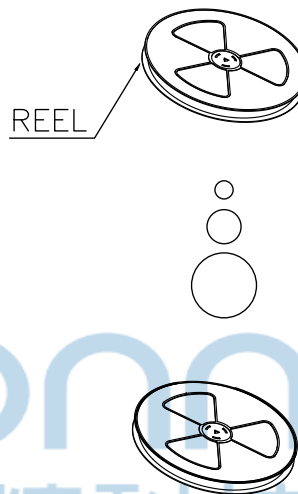
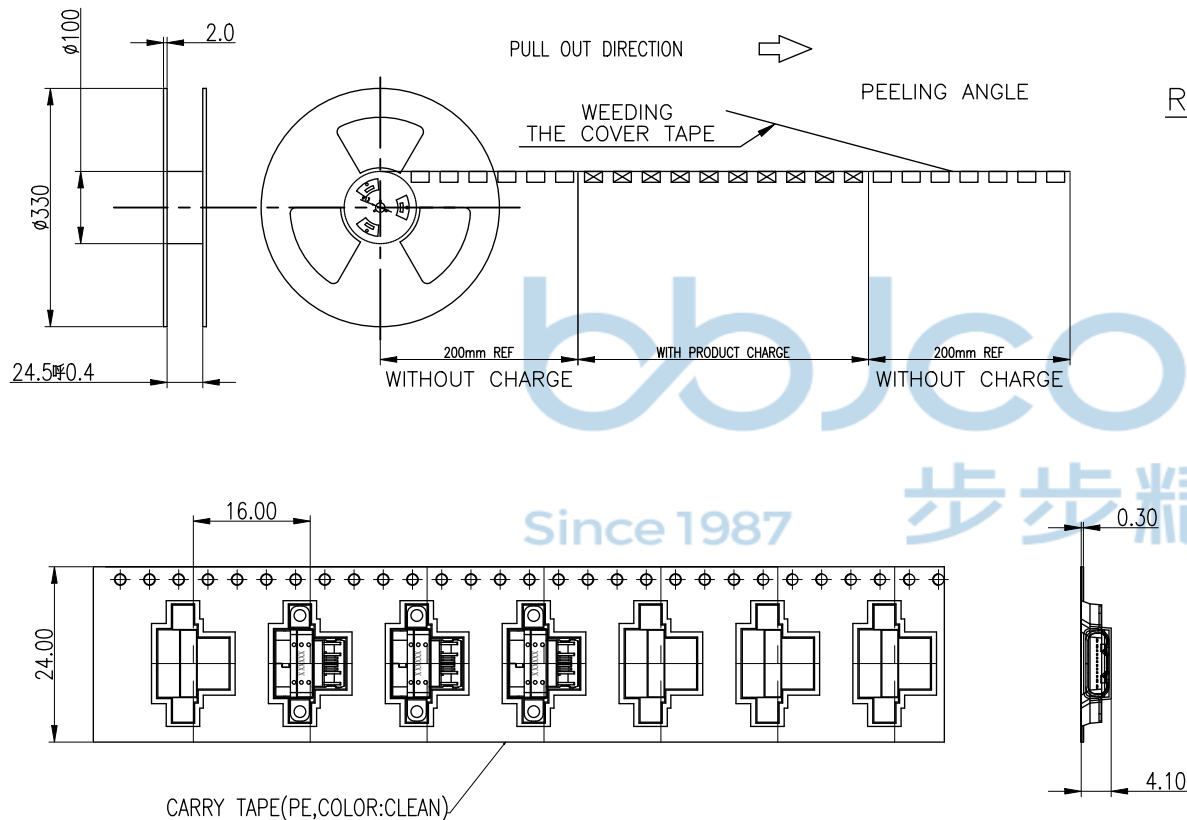

备注:

1. 包装数量: 1000PCS/REEL, 5 REEL/CARTON, 共5000PCS.
2. 材料: 纸箱: 纤维板, 瓦楞, 双层壁.
3. 载带剥离强度: 0.1 ~ 1.3 N(10 ~ 130克)
4. 脱皮速度: 300mm /min.
5. 外箱上贴号物料标签及RoHS标签
6. 同一产品只能装同一纸箱, 不允其它产品;
7. 每个袋子都应包括干燥剂\*1



THIS DOCUMENT IS THE SOLE PROPERTY OF BBJconn Technology Co.,Ltd. Corporation AND SHOULD NOT BE USED IN WHOLE OR IN PART WITHOUT PRIOR WRITTEN PERMISSION.		深圳市步步精科技有限公司 .X: ±0.38    .XX: ±0.25    .XXX: ±0.13 X': ±3"    X'': ±2"    XX': ±1"		NAME: TYPE-C 16P 母座 L=9.45 CH0.03 沉板1.6 带马甲 端子SMT	
APPD.	JM_Zheng	PJ. NO.: 126-221-160001-X7G		SIZE: A4   DRW NO.:	
CHKD.	LYX	FINISH: SEE NOTES		MAT'L.: SEE NOTES	
PDWG,NO:	0541-1	DR.	LYL	SCALE: N/A	REV.: A0   UNIT: mm   PAGE: 2/2