

REV.	DESCRIPTION	NAME	DATE
A	NEWS ISSUE		

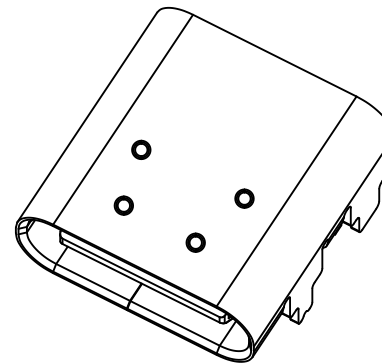
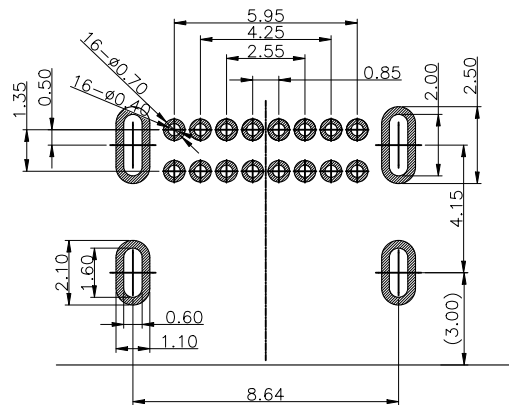
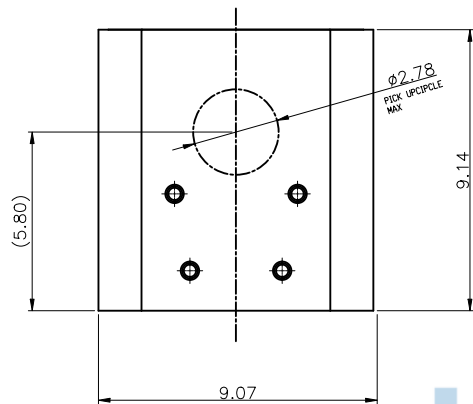

- NOTES:
- MATERIAL:
    - MOLDING: LCP UL94 V-0
    - CONTACT: COPPER ALLOY.
    - GOLD PLATED Min ON CONTACT AREA, 100u'
    - Min TIN (LEAD FREE) ON SOLDER AREA,
    - SHELL: SUS304-H, T=0.30±0.03mm
    - 50u' NICKEL PLATING OVER ALL.
    - MIDDLE SHILD: SUS304-H, T=0.20±0.03mm
  - MECHANICAL:
    - INSERTION: 5°~20N.
    - EXTRACTION: 8°~20N AFTER TEST.
    - DURABILITY: 10000 CYCLES
  - ELECTRICAL:
    - CURRENT: 5A FOR VBUS;
    - 1.25A FOR GND PIN.
    - 0.25A FOR OTHER.
    - VOLTAGE: 20 V MAX
    - WITHSTANDING VOLTAGE: 100V AC R. M. S.
    - CONTACT RESISTANCE: 40mΩ MAX.
    - INSULATION RESISTANCE: 100MΩ MIN.
  - ENVIRONMENTAL
    - TEMPERATURE RANGE -35° C ~ +85° C

RECOMMEND P.C.B LAYOUT (COMPONENT SIDE)

TOLERANCE FOR PCB LAYOUT IS ± 0.05

KEEP OUT AREA

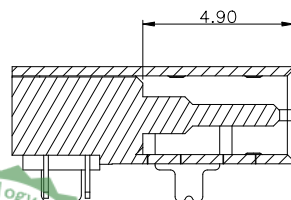
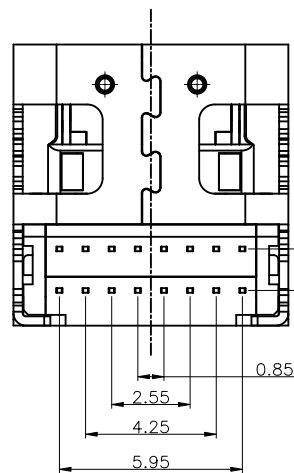
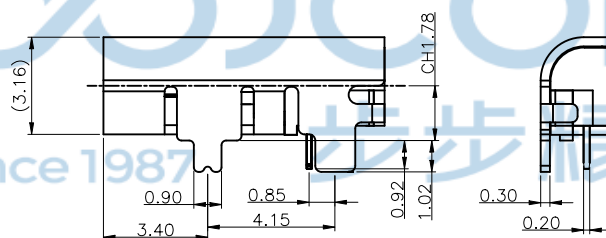
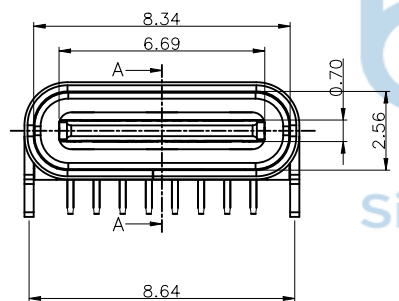

SECTION A-A

THIS DOCUMENT IS THE  
SOLE PROPERTY OF  
BBJconn Technology Co., Ltd.  
Corporation AND SHOULD  
NOT BE USED IN WHOLE  
OR IN PART WITHOUT  
PRIOR WRITTEN PERMISSION.

PDWG, NO: 0627-1



深圳市步步精科技有限公司

.X: ±0.38 X': ±3'  
.XX: ±0.25 .X': ±2'  
.XXX: ±0.13 .XX': ±1'

NAME:

TYPE-C 16P 母座 L=9.14 CH=1.78 板上四脚插 双排DIP 端子脚长0.92

APPD. JM\_Zheng

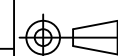

PJ. NO.: UC.01.11-1W-0010

CHKD. TSP

SIZE: A4 DRW NO.:

DR. LYX

FINISH: SEE NOTES MAT'L.: SEE NOTES

SCALE: REV.: A0 UNIT: mm PAGE: 1/3

REV.	DESCRIPTION	NAME	DATE
A	NEWS ISSUE		

出料方向  
PULL OUT DIRECTEON

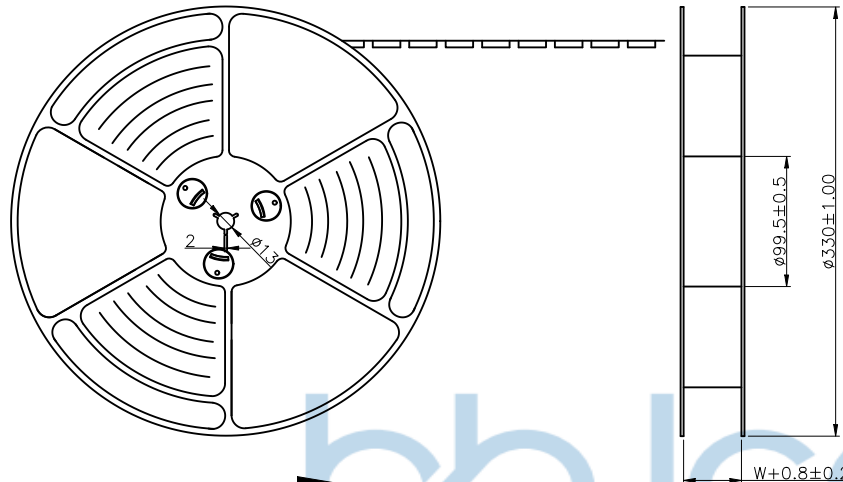

NOTES

- 帶子引導長度  
LEAD TAPE LENGTH  
出料方向  
PULL OUT DIRECTEON

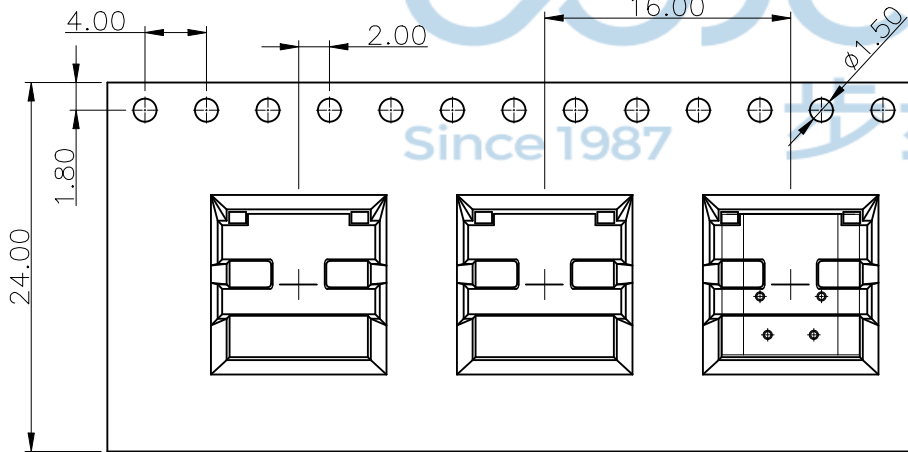
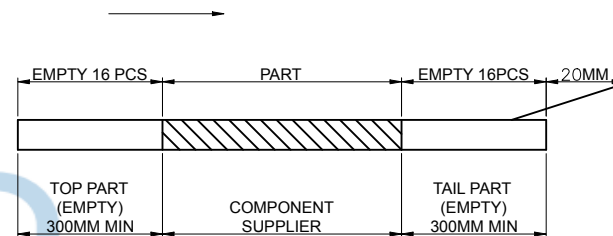

- 上帶剝力力為：0.1~1.3N(10.2gf~130gf)  
PEELING OFF FORCE OF TOP TAPE:0.1~1.3N(10.2gf~130gf)  
出貨運輸過程中一定注意：  
THIS REQUIREMENT SHOULD BE APPLIED AT SHIPMENT：  
卷帶在運輸過程中不能散開  
PEELING OFF SHOULD NOT BE ALLOWED DURING TRANSPORTATION

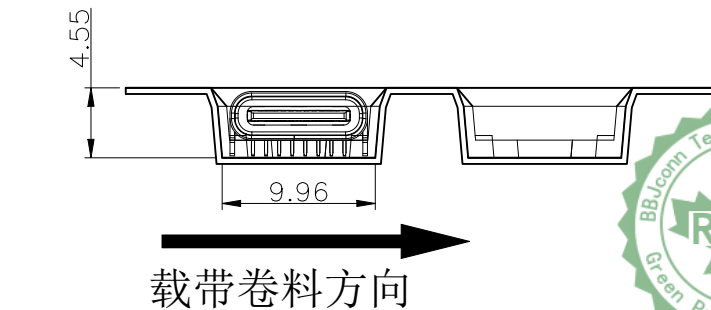
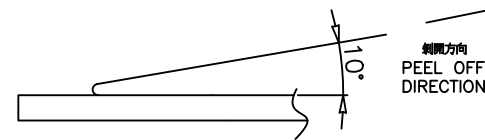

THIS DOCUMENT IS THE  
SOLE PROPERTY OF  
BBJconn Technology Co.,Ltd.  
Corporation AND SHOULD  
NOT BE USED IN WHOLE  
OR IN PART WITHOUT  
PRIOR WRITTEN PERMISSION.  
PDWG,NO: 0627-1

**深圳市步步精科技有限公司**

.X: ±0.38	X': ±3'	NAME:
.XX: ±0.25	.X': ±2'	TYPE-C 16P 母座 L=9.14 CH=1.78 板上四脚插 双排DIP 端子脚长0.92
.XXX: ±0.13	.XX': ±1'	APPD. JM_Zheng
APPD. JM_Zheng	CHKD. TSP	DR. LYX
		PJ. NO.: UC.01.11-1W-0010
		SIZE: A4   DRW NO.:
FINISH: SEE NOTES		MAT'L.: SEE NOTES
SCALE:		REV.: A0 UNIT: mm PAGE: 2/3

REV.	DESCRIPTION	NAME	DATE
A	NEWS ISSUE		

at small positioning hole of the carrier tape side).  
標簽黏貼處 (朝捲裝包材的小定位孔一側)

Location of label sticking (label)

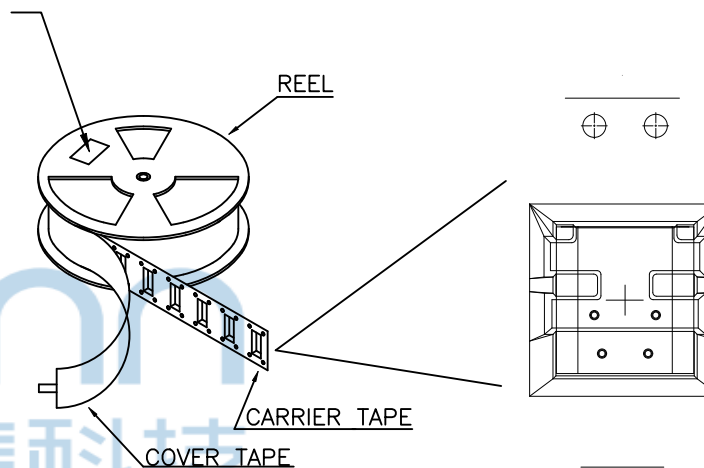
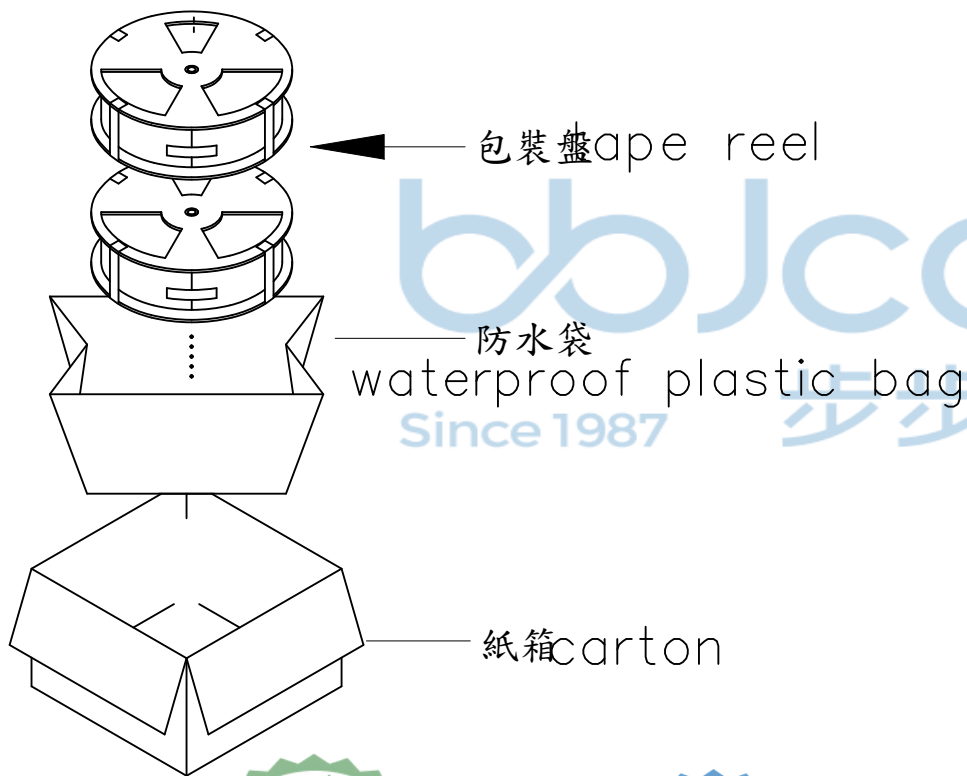

NOTE:

1. 每捲包裝數量及每箱裝箱數量如左下表格.
2. 以上膠帶覆蓋下包裝帶經包裝機冷封包裝
3. 每個紙箱放2個珍珠棉
4. 將裝滿產品的卷盤放入紙箱并以膠帶封口



THIS DOCUMENT IS THE  
SOLE PROPERTY OF  
BBJconn Technology Co.,Ltd.  
Corporation AND SHOULD  
NOT BE USED IN WHOLE  
OR IN PART WITHOUT  
PRIOR WRITTEN PERMISSION.

**深圳市步步精科技有限公司**

.X: ±0.38 X': ±3'  
.XX: ±0.25 .X': ±2'  
.XXX: ±0.13 .XX': ±1'

NAME:  
TYPE-C 16P 母座 L=9.14 CH=1.78 板上四脚插 双排DIP 端子脚长0.92

APPD. JM\_Zheng

PJ. NO.: UC.01.11-1W-0010

CHKD. TSP

SIZE: A4 DRW NO.:

FINISH: SEE NOTES MAT'L.: SEE NOTES

PDWG,NO: 0627-1

DR. LYX

SCALE: REV.: A0 UNIT: mm PAGE: 3/3

包裝容量 (PACKING CAPACITY)			重量 WEIGHT (Kg)		
PCS/REEL	REELS/CARTON	PCS/CARTON	N.W./PCS	N.W./BOX	G.W./BOX
1000	10	10000			