

| REV. | ECN NO | CONTENT         | DATE | ENGINEER |
|------|--------|-----------------|------|----------|
| A0   |        | Initial release | /    | TSP      |

NOTE/注释:

- SPECIFICATION/规格:
  - Rated current (额定电流): 5.0 A
  - Voltage rating (额定电压): 5V AC
  - Contact Resistance (接触阻抗): 40 m Ω Max.
  - Insulation Resistance (绝缘阻抗): 100MΩ Min.
  - Withstanding voltage (耐电压): 100 VAC/minute
  - Mating force (插入力): 5~20N.
  - Unmating force (拔出力): 8~20N.
  - Durability Cycle(寿命循环): 10,000 cycle
  - Operating temperature (工作温度): -40°~+85°

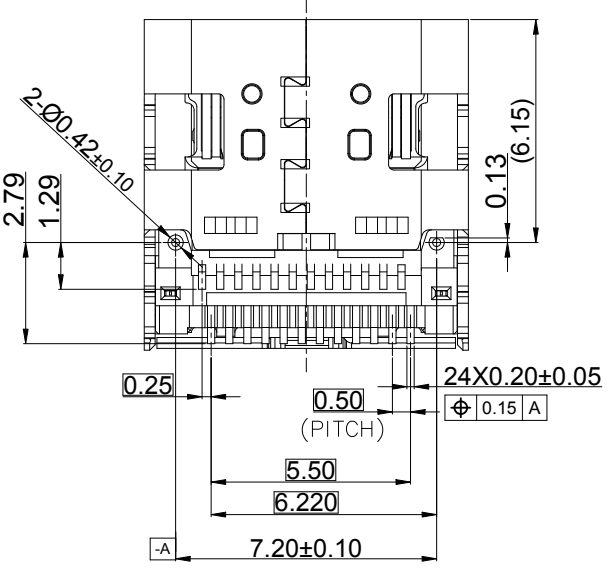
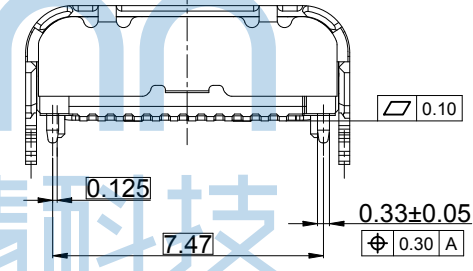
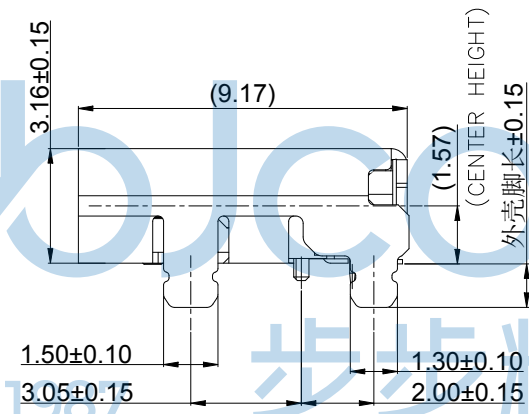
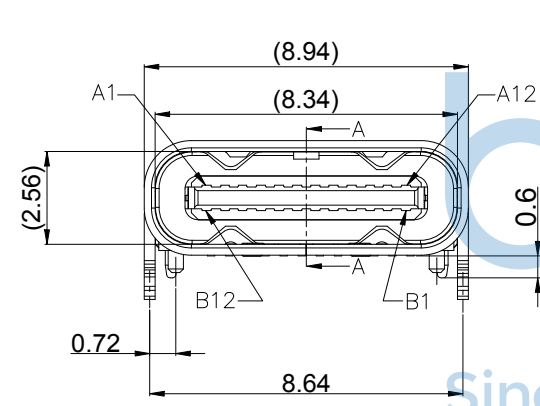
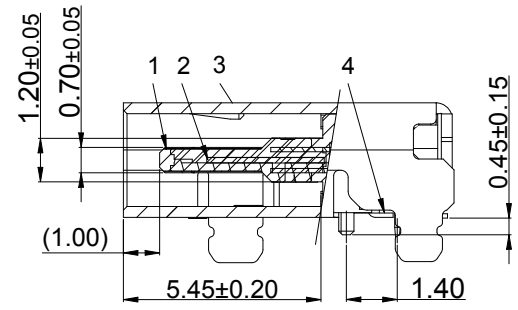
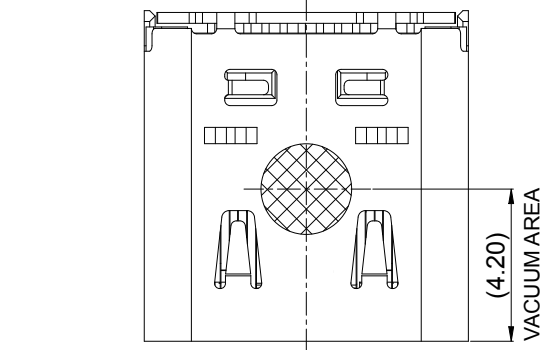

|      |
|------|
| 1.60 |
| 1.20 |
| 0.90 |
| 0.60 |
| 外壳脚长 |

PIN ASSIGNMENT:

|     |      |      |      |      |    |    |      |      |      |      |     |
|-----|------|------|------|------|----|----|------|------|------|------|-----|
| A1  | A2   | A3   | A4   | A5   | A6 | A7 | A8   | A9   | A10  | A11  | A12 |
| GND | TX1+ | TX1- | Vbus | CC1  | D+ | D- | SBU1 | Vbus | RX2- | RX2+ | GND |
| GND | RX1+ | RX1- | Vbus | SBU2 | D- | D+ | CC2  | Vbus | TX2- | TX2+ | GND |
| B12 | B11  | B10  | B9   | B8   | B7 | B6 | B5   | B4   | B3   | B2   | B1  |

|  |                     |  |                                     |
|--|---------------------|--|-------------------------------------|
| THIS DOCUMENT IS THE SOLE PROPERTY OF BBJconn Technology Co.,Ltd. Corporation AND SHOULD NOT BE USED IN WHOLE OR IN PART WITHOUT PRIOR WRITTEN PERMISSION. PDWG.NO: 0470-1 | <b>深圳市步步精科技有限公司</b> | NAME: USB 4.0 TYPE-C 24P 母座 有后盖 单壳 板上四脚插 带柱 端子双排SMT 外壳脚长0.60 L=9.17 CH=1.57 编带 |                                     |
|  |                     | APPD. JM_Zheng   | PJ. NO.: 126-223-240005-U4G         |
|  |                     | CHKD. LYX  | SIZE: A4 DRW NO.:                   |
|  |                     | DR. TSP  | FINISH: SEE NOTES MAT'L.: SEE NOTES |
|  |                     | SCALE: N/A REV.: A0 UNIT: mm PAGE: 1/3   |                                     |

|      |        |                 |      |          |
|------|--------|-----------------|------|----------|
| REV. | ECN NO | CONTENT         | DATE | ENGINEER |
| A0   |        | Initial release | /    | TSP      |

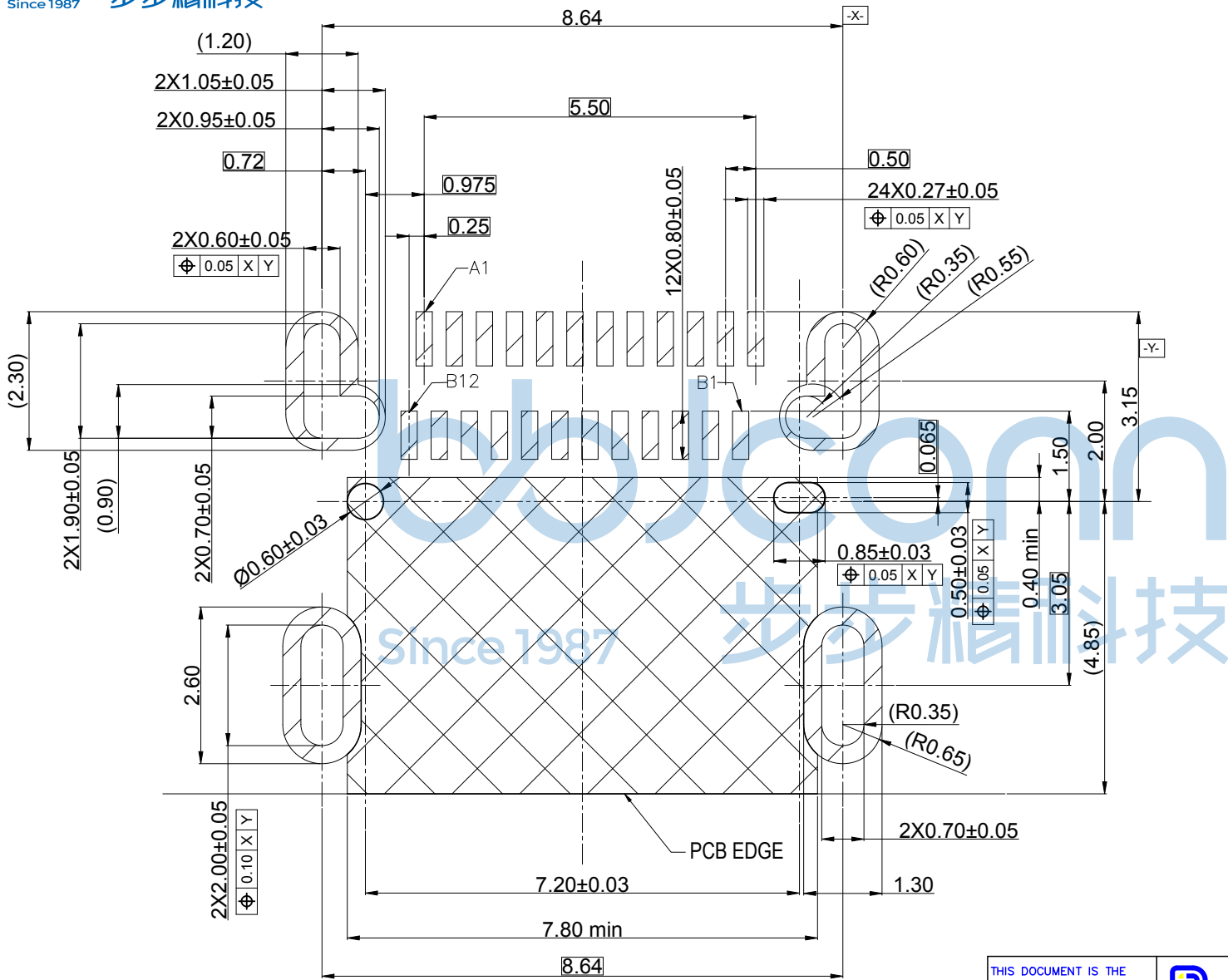

| ITEM             | DESCRIPTION  | QTY | MATERIAL                       | FINISH  | REMARK  |
|------------------|--------------|-----|--------------------------------|---|---------|
| 4                | TERMINAL     | 24  | COPPER ALLOY<br>XYK-40(C18140) | MATING SIDE: Au1u"<br>SOLDER TAIL: Gold FLASH, 50u" NICKEL OVERALL. | T=0.12  |
| 3                | SHELL        | 1   | SUS304                         | 30U" NICKEL PLATING   | T=0.30  |
| 2                | MID PLATE    | 1   | SUS301                         | 30U" NICKEL PLATING   | T=0.15  |
| 1                | MAIN HOUSING | 1   | HIGH TEMPERATURE               | PA9T UL94 V-0, BLACK  | UL94V-0 |
| BILL OF MATERIAL |              |     |                                |   |         |

THIS DOCUMENT IS THE SOLE PROPERTY OF BBJconn Technology Co., Ltd. Corporation AND SHOULD NOT BE USED IN WHOLE OR IN PART WITHOUT PRIOR WRITTEN PERMISSION.

PDWG. NO: 0470-1

**深圳市步步精科技有限公司**

.X: ±0.38 .X': ±3"  
.XX: ±0.25 .X'': ±2"  
.XXX: ±0.13 .X''': ±1"

NAME: USB 4.0 TYPE-C 24P 母座 有后盖 单壳 板上四脚插  
带柱 端子双排SMT 外壳脚长0.60 L=9.17 CH=1.57 编带

APPD. JM\_Zheng  
CHKD. LYX  
DR. TSP

PJ. NO.: 126-223-240005-U4G  
SIZE: A4 | DRW NO.:  
FINISH: SEE NOTES | MAT'L.: SEE NOTES  
SCALE: N/A | REV.: A0 | UNIT: mm | PAGE: 2/3



| REV. | ECN NO | CONTENT         | DATE | ENGINEER |
|------|--------|-----------------|------|----------|
| A0   |        | Initial release | /    | TSP      |

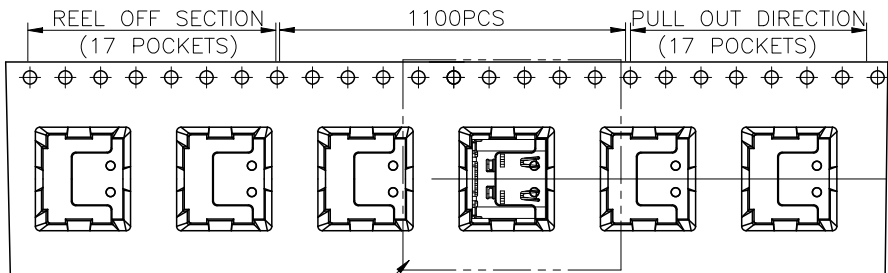

SEE DETAIL X

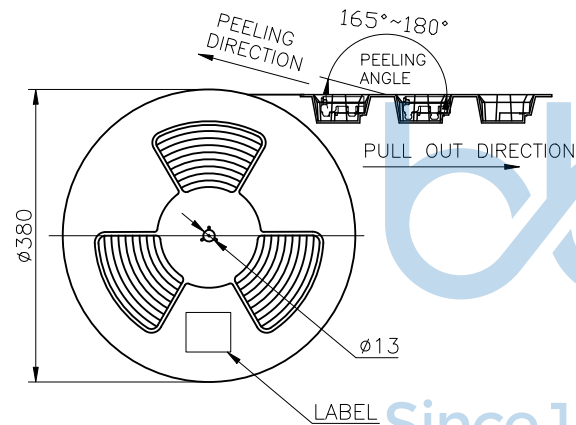

W+0.5

PAPER BOARD

REEL AND TAPE

REEL AND TAPE

PAPER BOARD

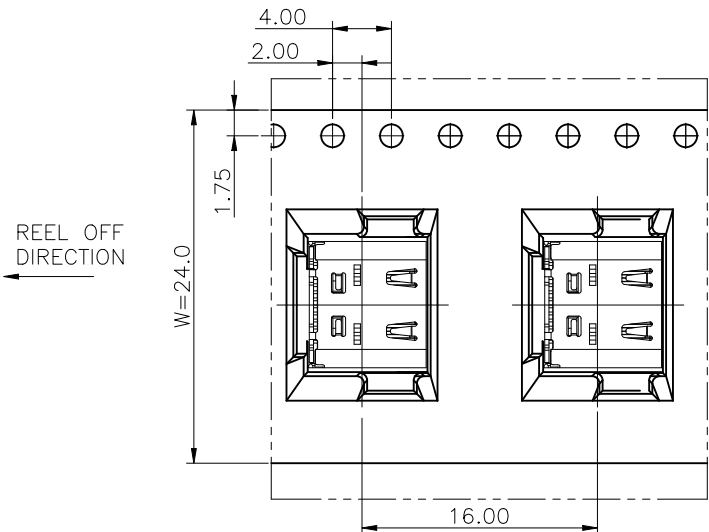
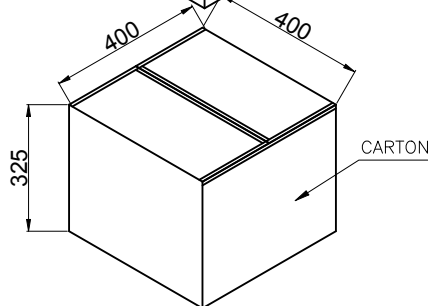
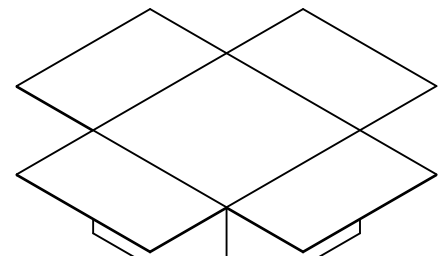
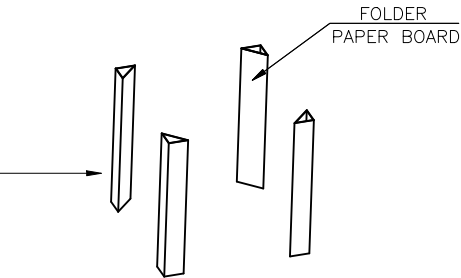

|                 |      |        |
|-----------------|------|--------|
|                 | REEL | CARTON |
| CONNECTOR (PCS) | 1100 | 11000  |



THIS DOCUMENT IS THE SOLE PROPERTY OF **bbJconn Technology Co., Ltd.** 深圳市步步精科技有限公司

Corporation AND SHOULD NOT BE USED IN WHOLE OR IN PART WITHOUT PRIOR WRITTEN PERMISSION.

PDWG.NO: 0470-1

NAME: USB 4.0 TYPE-C 24P 母座 有后盖 单壳 板上四脚插 带柱 端子双排SMT 外壳脚长0.60 L=9.17 CH=1.57 编带

PJ. NO.: 126-223-240005-U4G

SIZE: A4 DRW NO.:

FINISH: SEE NOTES MAT'L.: SEE NOTES

SCALE: N/A REV.: A0 UNIT: mm PAGE: 3/3

|       |          |
|-------|----------|
| APPD. | JM_Zheng |
| CHKD. | LYX      |
| DR.   | TSP      |