

REV.	ECN NO	CONTENT	DATE	ENGINEER
A0		Initial release	/	LYL

NOTES:

- MATERIAL:**  
MOLDING: LCP UL94 V-0  
CONTACT: COPPER ALLOY.  
PLATED GOLD ON CONTACT AREA,  
G/F GOLD ON SOLDER AREA,  
50u" NICKEL PLATING OVER ALL.  
SHELL: SUS304, T=0.20±0.03mm  
50u" NICKEL PLATING OVER ALL.  
SHELL2: SUS304, T=0.15±0.03mm  
LATCH: SUS301, T=0.15±0.03mm
- MECHANICAL:**  
INSERTION: 5°~20N.  
EXTRACTION: 8°~20N.  
DURABILITY: 10000 CYCLES
- ELECTRICAL:**  
CURRENT: 5A MAX FOR VBUS;  
1.25A FOR GND, 0.25A FOR OTHER OTHER.  
VOLTAGE: 20VDC MAX  
WITHSTANDING VOLTAGE: 100V AC.  
CONTACT RESISTANCE: 40mΩ MAX.  
INSULATION RESISTANCE: 100MΩ MIN.
- ENVIRONMENTAL**  
TEMPERATURE RANGE -25° C ~ +85° C

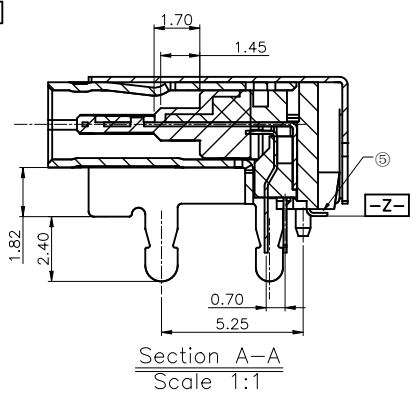
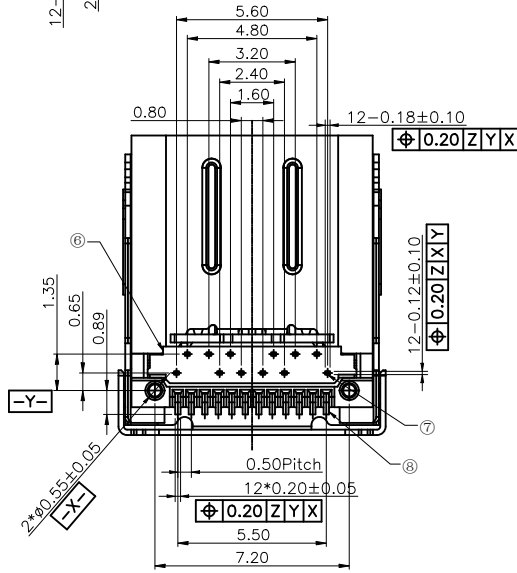
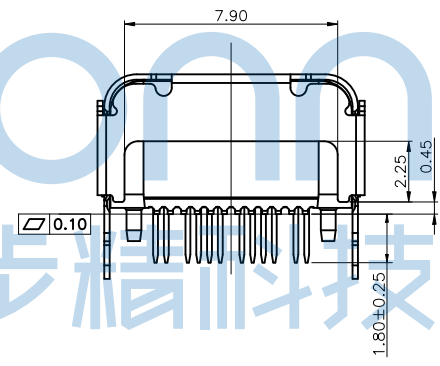
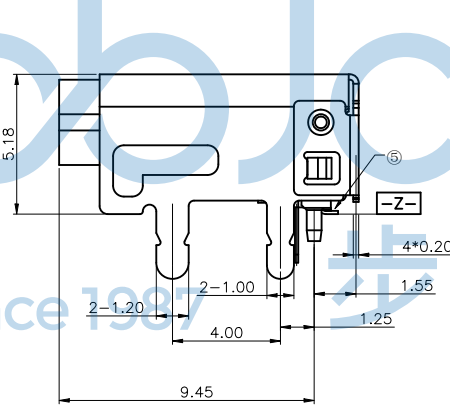
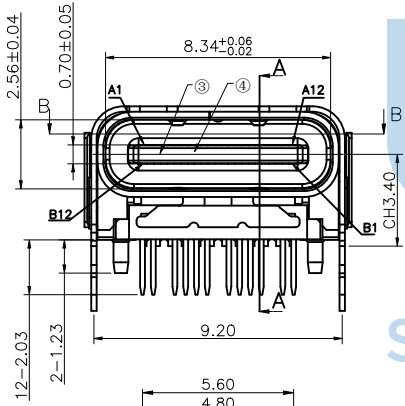
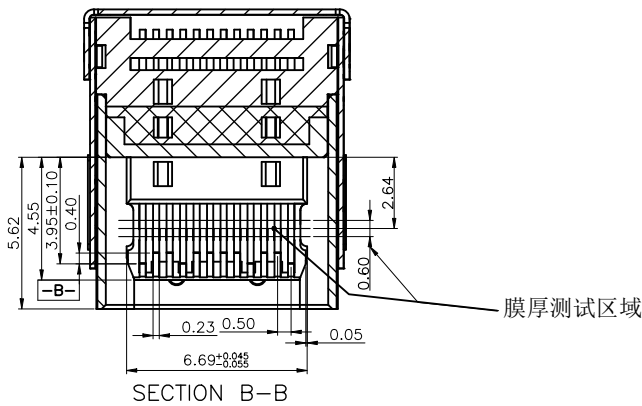
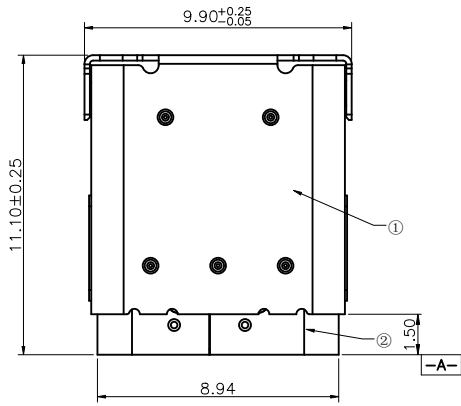

THIS DOCUMENT IS THE SOLE PROPERTY OF BBJconn Technology Co.,Ltd. Corporation AND SHOULD NOT BE USED IN WHOLE OR IN PART WITHOUT PRIOR WRITTEN PERMISSION. PDWG:NO: 0228-1		<b>深圳市步步精科技有限公司</b>	
.X: ±0.38 .XX: ±0.25 .XXX: ±0.13	.X': ±3' .X'': ±2' .X'X': ±1'	NAME: TYPE-C 24P 母座 双壳 无翻边 板上四脚插 带柱 端子SMT+DIP 脚距4.0 外壳脚长2.4 DIP脚长1.8 垫高1.82 L=11.10 CH=3.40 编带	
APPD. JM_Zheng	CHKD. LYX	P.J. NO.: 126-223-240003-T7G	
DR. LYL		SIZE: A4 DRW NO.:	
		FINISH: SEE NOTES MAT'L.: SEE NOTES	
		SCALE: N/A REV.: A0 UNIT: mm PAGE: 1/4	

REV.	ECN NO	CONTENT	DATE	ENGINEER
A0		Initial release	/	LYL

USB TYPE-C FULL-FEATURED RECEPTACLE INTERFACE PIN ASSIGNMENTS

PIN	Signal Name	Description	PIN	Signal Name	Description
A1	GND	Ground return	B12	GND	Ground return
A2	SSTXp1	Positive half of first SuperSpeed TX differential pair	B11	SSRXp1	Positive half of first SuperSpeed RX differential pair
A3	SSTXn1	Negative half of first SuperSpeed TX differential pair	B10	SSRXn1	Negative half of first SuperSpeed RX differential pair
A4	VBUS	Bus Power	B9	VBUS	Bus Power
A5	CC1	Configuration Channel	B8	SBU2	Sideband Use (SBU)
A6	Dp1	Positive half of the USB 2.0 differential pair-Position 1	B7	Dn2	Negative half of the USB 2.0 differential pair-Position 2
A7	Dn1	Negative half of the USB 2.0 differential pair-Position 1	B6	Dp2	Positive half of the USB 2.0 differential pair-Position 2
A8	SBU1	Sideband Use(SBU)	B5	CC2	Configuration Channel
A9	VBUS	Bus Power	B4	VBUS	Bus Power
A10	SSRXn2	Negative half of second SuperSpeed RX differential pair	B3	SSTXn2	Negative half of second SuperSpeed TX differential pair
A11	SSRXp2	Positive half of second SuperSpeed RX differential pair	B2	SSTXp2	Positive half of second SuperSpeed TX differential pair
A12	GND	Ground return	B1	GND	Ground return

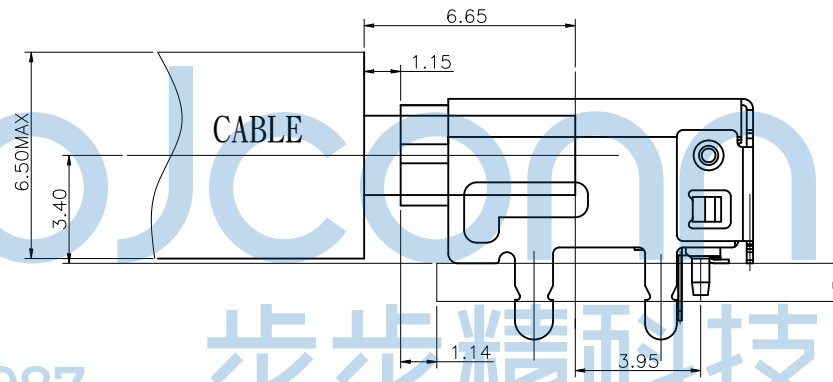
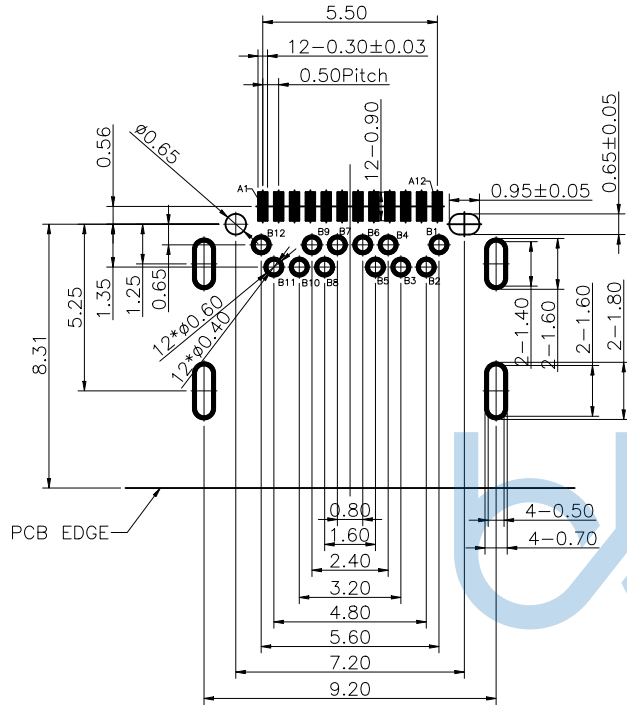

RECOMMENDED PCB LAYOUT(COMPONENT SIDE)

PCB THICKNESS: 1.60±0.05  
DEFAULT TOLERANCE: ±0.05

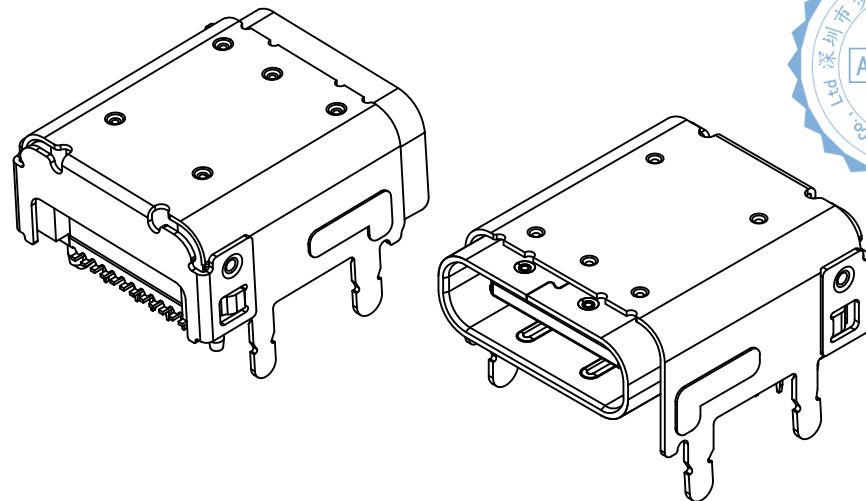

8	UPPER CONTACT	12	COPPER ALLOY	Ni 50u"Min AT TAIL, 1U" Min Au AT SOLDER
7	LOWER CONTACT	12		AU 30u" Min AT CONNECT AREA Ni 80u"Min.
6	LOWER IM	1	THERMOPLASTIC UL 94V-0	COLOR: BLACK
5	UPPER IM	1	THERMOPLASTIC UL 94V-0	COLOR: BLACK
4	OVERMOLD	1	THERMOPLASTIC UL 94V-0	COLOR: BLACK
3	SHIELD PLATE	1	STAINLESS STEEL	NICKEL PLATING AT OVER ALL
2	INNER SHELL	1	STAINLESS STEEL	CLEAN
1	OUTER SHELL	1	STAINLESS STEEL	NICKEL PLATING ONLY AT TAIL,AU AT SOLDER TAIL
NO.	DESCRIPTION	QTY	MATERIAL	SPECIFICATION

THIS DOCUMENT IS THE SOLE PROPERTY OF BBJconn Technology Co.,Ltd. Corporation AND SHOULD NOT BE USED IN WHOLE OR IN PART WITHOUT PRIOR WRITTEN PERMISSION.

PDWG:NO: 0228-1

APPD. JM\_Zheng  
CHKD. LYX  
DR. LYL

NAME: TYPE-C 24P 母座 双壳 无翻边 板上四脚插 带柱 端子SMT+DIP  
脚距4.0 外壳脚长2.4 DIP脚长1.8 垫高1.82 L=11.10 CH=3.40 编带

PJ. NO.: 126-223-240003-T7G  
SIZE: A4 DRW NO.:  
FINISH: SEE NOTES MAT'L.: SEE NOTES  
SCALE: N/A REV.: A0 UNIT: mm PAGE: 2/4

**深圳市步步精科技有限公司**

REV.	ECN NO	CONTENT	DATE	ENGINEER
A0		Initial release	/	LYL

出料方向  
PULL OUT DIRECTEON

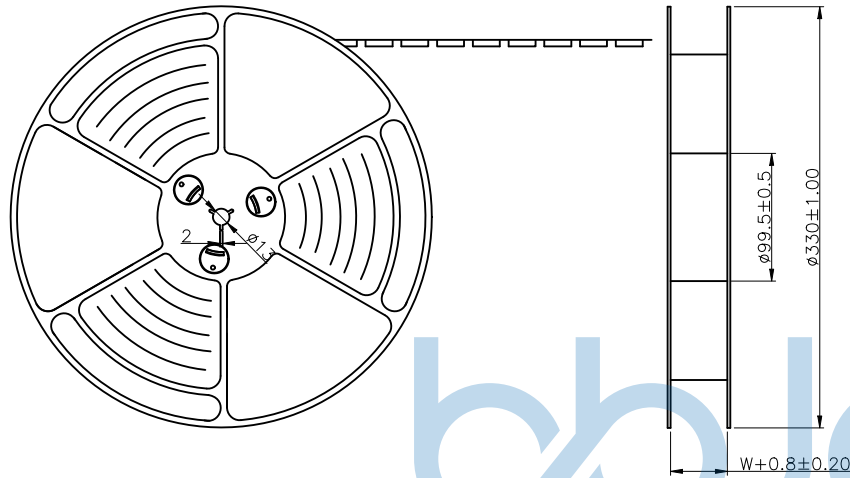

NOTES

- 帶子引導長度  
LEAD TAPE LENGTH  
出料方向  
PULL OUT DIRECTEON

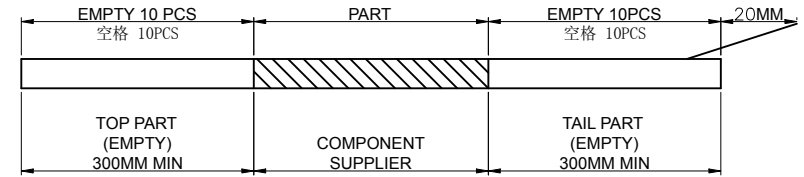

- 出貨運輸過程中一定要注意:  
THIS REQUIREMENT SHOULD BE APPLIED AT SHIPMENT:  
卷帶在運輸過程中不能散開  
PEELING OFF SHOULD NOT BE ALLOWED DURING TRANSPORTATION

Since 1987

步步精科技

拉出方向  
PULL OUT DIRECTION

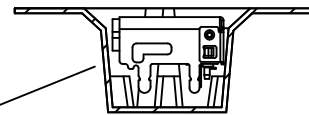
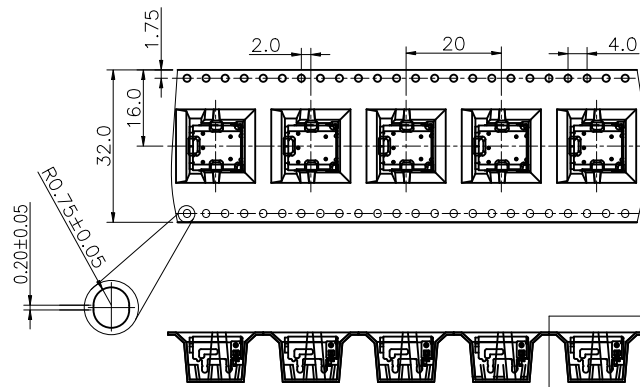

局部(DETAIL) A  
2:1

产品放置方式示意图  
PLACE PRODUCT AREA

局部(DETAIL) A



THIS DOCUMENT IS THE SOLE PROPERTY OF BBJconn Technology Co.,Ltd. Corporation AND SHOULD NOT BE USED IN WHOLE OR IN PART WITHOUT PRIOR WRITTEN PERMISSION.		<b>深圳市步步精科技有限公司</b>	
PDWG:NO: 0228-1	APPD. JM_Zheng	NAME: TYPE-C 24P 母座 双壳 无翻边 板上四脚插 带柱 端子SMT+DIP 脚距4.0 外壳脚长2.4 DIP脚长1.8 垫高1.82 L=11.10 CH=3.40 编带	
	CHKD. LYX	PJ. NO.: 126-223-240003-T7G	
	DR. LYL	SIZE: A4 DRW NO.:	
		FINISH: SEE NOTES	MAT'L.: SEE NOTES
		SCALE: N/A	REV.: A0 UNIT: mm PAGE: 3/4

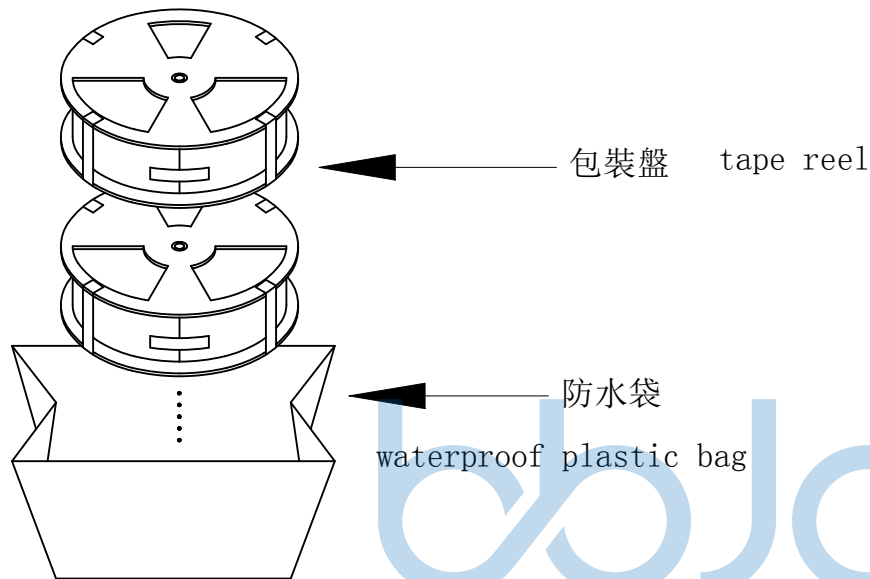

at small positioning hole of the carrier tape side).  
標籤黏貼處 (朝捲裝包材的小定位孔一側)

Location of label sticking (label)

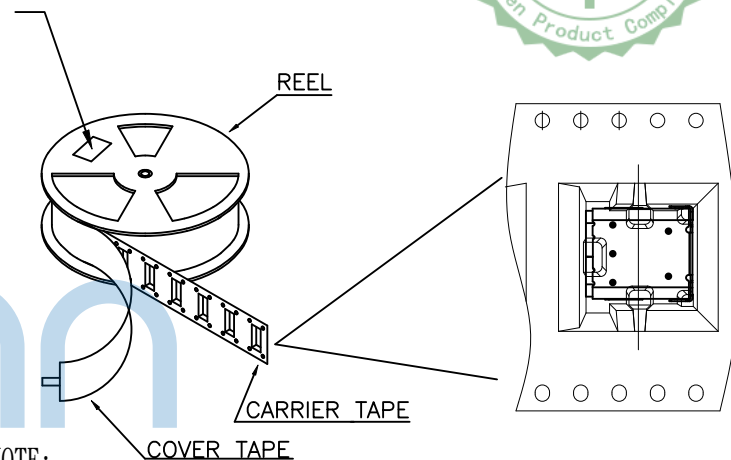

NOTE:

- 每卷包裝數量及每箱裝箱數量如左下表格。  
Packing q'ty of each reel & carton as below table shown.
- 以上帶覆蓋下載帶經包裝機自粘包裝  
The above tape covers the download tape by self-adhesive packaging machine.
- 將裝滿產品的卷盤放入紙箱并以膠帶封口  
Put reels in the carton and use adhesive tape to seal up.

Since 1987

步步精科技

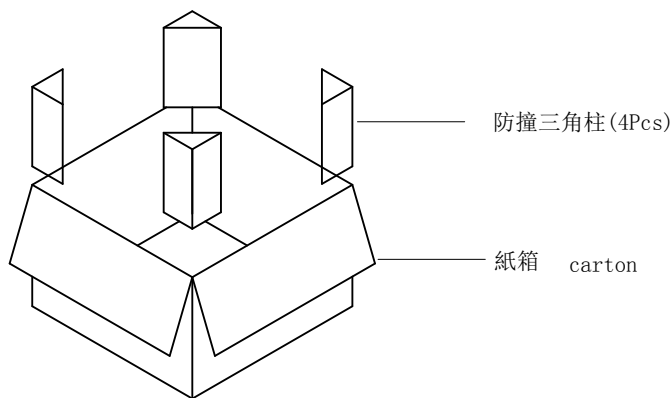

包裝數量 (PACKING CAPACITY)			重量 WEIGHT (Kg)		
PCS/REEL	REELS/CARTON	PCS/CARTON	N.W./PCS	N.W./BOX	G.W./BOX
550	10	5500	0.782		

THIS DOCUMENT IS THE SOLE PROPERTY OF BBJconn Technology Co.,Ltd. Corporation AND SHOULD NOT BE USED IN WHOLE OR IN PART WITHOUT PRIOR WRITTEN PERMISSION.		<b>深圳市步步精科技有限公司</b>	
.X: ±0.38 .XX: ±0.25 .XXX: ±0.13		X': ±3" .X': ±2" .XX': ±1"	
APPD. JM_Zheng		NAME: TYPE-C 24P 母座 双壳 无翻边 板上四脚插 带柱 端子SMT+DIP 脚距4.0 外壳脚长2.4 DIP脚长1.8 垫高1.82 L=11.10 CH=3.40 编带	
CHKD. LYX		PJ. NO.: 126-223-240003-T7G	
PDWG.NO: 0228-1		SIZE: A4 DRW NO.:	
DR. LYL		FINISH: SEE NOTES MAT'L.: SEE NOTES	
		SCALE: N/A REV.: A0 UNIT: mm PAGE: 4/4	