

REV.	ECN NO	CONTENT	DATE	ENGINEER
A0				

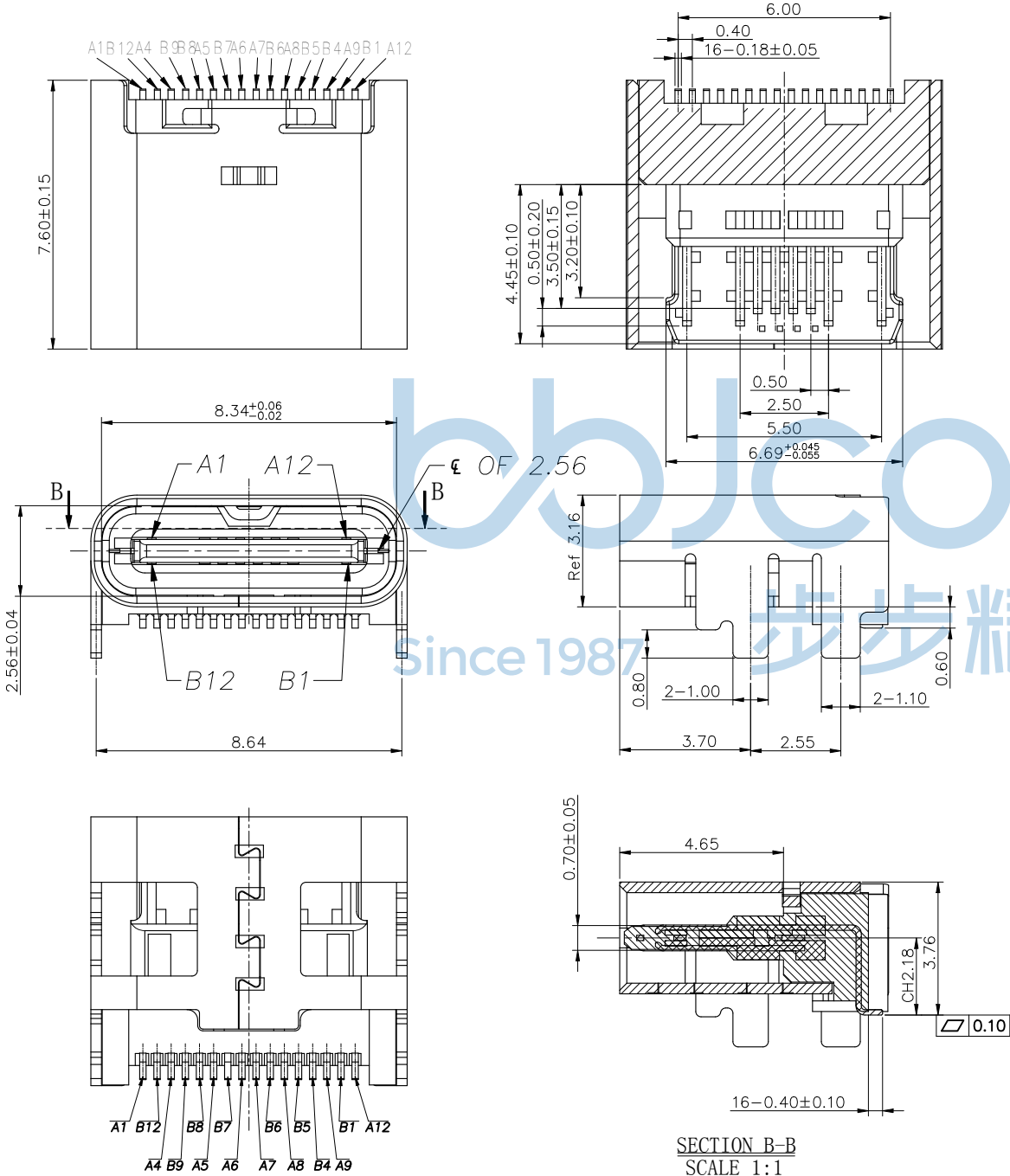

SECTION B-B
SCALE 1:1

NOTE:

- MATERIAL SPECIFICATION:
 - HOUSING: HIGH TEMPERATURE RESISTANT PLASTIC, UL94 V-0.
 - CONTACTS: COPPER ALLOY
 - SHELL: STAINLESS STEEL
 - MID PLATE: STAINLESS STEEL
- PLATING SPECIFICATION:
 - CONTACTS:
 - Ni 50u" MIN. UNDER PLATED OVER ALL.
 - Au G/F PLATED ON THE FUNCTIONAL AREA OF CONTACT. (GOLD PLATING THICKNESS FOLLOW)
 - GOLD FLASH PLATING ON SOLDER AREA
 - FRONT SHELL:
 - Ni 30u" MIN. UNDER PLATED OVER ALL.
- MECHANICAL PERFORMANCE,
 - INSERTION FORCE: 0.5~2.0kgf.
 - REMOVAL FORCE: 0.8kgf~2.0kgf.
 - DURABILITY: 10000 CYCLES.
- ELECTRICAL PERFORMANCE,
 - CURRENT RATING: 5.0A
VOLTAGE RATING: 20V
 - INSULATION RESISTANCE: 100MΩ MIN
 - DIELECTRIC WITHSTAND VOLTAGE, AC 100V FOR 1 MINUTE
 - LOW CONTACT RESISTANCE: INITIAL 40MΩ
AFTER 50MΩ
- ENVIRONMENTAL PERFORMANCE:
 - OPERATING TEMPERATURE: -30°C~+80°C.
- IR REFLOW:
 - THE PEAK TEMPERATURE ON THE BOARD SHALL BE MAINTAINED FOR 10 SECONDS AT 260°C.



THIS DOCUMENT IS THE SOLE PROPERTY OF BBJconn Technology Co., Ltd. Corporation AND SHOULD NOT BE USED IN WHOLE OR IN PART WITHOUT PRIOR WRITTEN PERMISSION.		深圳市步步精科技有限公司 工程	
PDWG. NO: 0100-2	DR. TSP	NAME: TYPE-C 16PIN 母座 L=7.60 CH=2.18 垫高0.60 板上四脚插 端子SMT APPD. JM_Zheng CHKD. LYX	PJ. NO.: UC.01.51-11-0061 SIZE: A4 DRW NO.: FINISH: SEE NOTES MAT'L.: SEE NOTES SCALE: N/A REV.: A0 UNIT: mm PAGE: 1/3

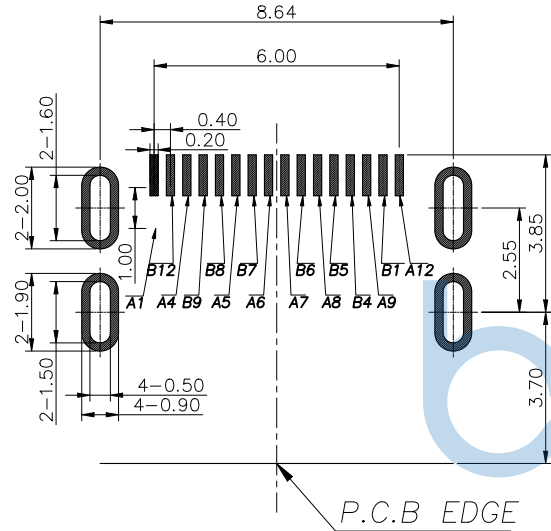

USB TYPE-C PIN ASSIGNMENTS

PIN NUMBER	SIGNAL NAME
A1	GND
A4	VBUS
A5	CC1
A6	Dp1
A7	Dn1
A8	SBU1
A9	VBUS
A12	GND

PIN NUMBER	SIGNAL NAME
B12	GND
B9	VBUS
B8	SBU2
B7	Dn2
B6	Dp2
B5	CC2
B4	VBUS
B1	GND

RECOMMEND P.C.B LAYOUT (COMPONENT SIDE)
TOLERANCE FOR PCB LAYOUT IS ± 0.05

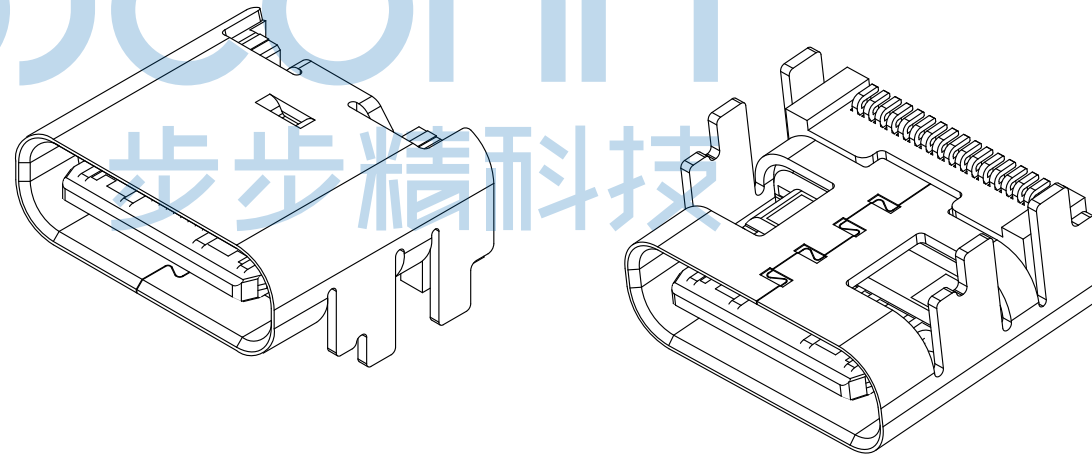

THIS DOCUMENT IS THE SOLE PROPERTY OF BBJconn Technology Co., Ltd. Corporation AND SHOULD NOT BE USED IN WHOLE OR IN PART WITHOUT PRIOR WRITTEN PERMISSION.		深圳市步步精科技有限公司 .X: ± 0.38 .XX: ± 0.25 .XXX: ± 0.13 X': $\pm 3'$ X'': $\pm 2'$ XX': $\pm 1'$	
APPD.	JM_Zheng	NAME: TYPE-C 16PIN 母座 L=7.60 CH=2.18 垫高0.60 板上四脚插 端子SMT	
CHKD.	LYX	PJ. NO.: UC.01.51-11-0061	
DR.	TSP	SIZE: A4 DRW NO.:	
PDWG.NO: 0100-2		FINISH: SEE NOTES MAT'L.: SEE NOTES	
		SCALE: N/A REV.: A0 UNIT: mm PAGE: 2/3	

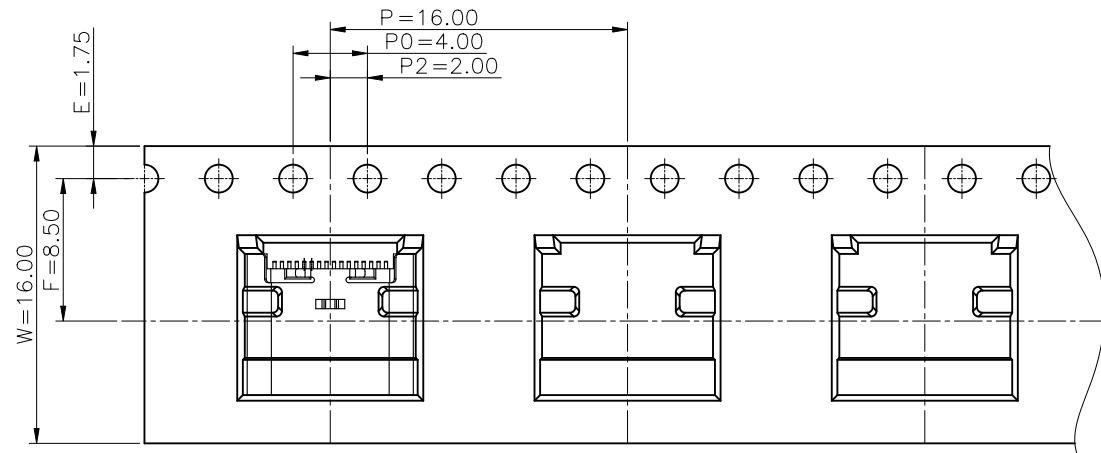
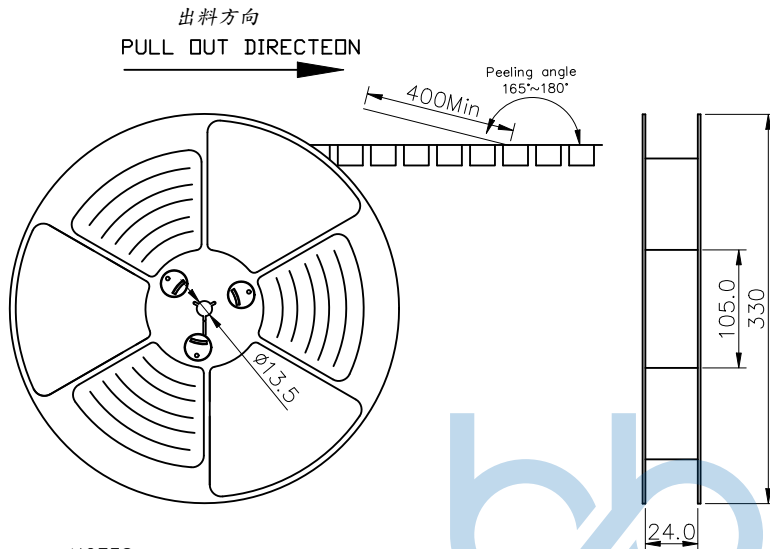

NOTES

1. 帶子引導長度
LEAD TAPE LENGTH
出料方向
PULL OUT DIRECTEON

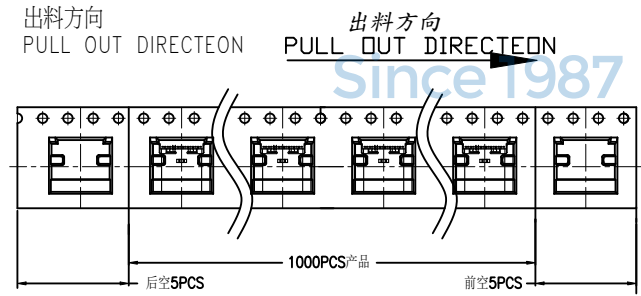

2. 上帶 剝力力為 : 0.1~1.3N(10.2gf~130gf)
PEELING OFF FORCE OF TOP TAPE: 0.1~1.3N(10.2gf~130gf)
出貨運輸過程中一定注意:
THIS REQUIREMENT SHOULD BE APPLIED AT SHIPMENT:
卷帶在運輸過程中不能散開
PEELING OFF SHOULD NOT BE ALLOWED DURING TRANSPORTATION

TAPE & REEL 10 PCS

1 REEL = 1000 PCS

BOX

DIMENSIONS:
33.5X33.5X30.5

1 CARTON = 10 REELS = 10000 PCS



包裝明細表 (The detail of the packing)						
產品料號 (Product No.)	包裝容量 (Packing Capacity)			重量 Weight (Kg)		
	pcs/box	boxs/Carton	Pcs/Box	N. W. /Pcs	N. W. /Box	G. W. /Box
UC. 01. 51-11-0061	1000	10	10000	----	----	----

THIS DOCUMENT IS THE SOLE PROPERTY OF BBJconn Technology Co.,Ltd. Corporation AND SHOULD NOT BE USED IN WHOLE OR IN PART WITHOUT PRIOR WRITTEN PERMISSION.		深圳市步步精科技有限公司 .X: ±0.38 .X': ±3' .XX: ±0.25 .X'': ±2' .XXX: ±0.13 .X''': ±1'		NAME: TYPE-C 16PIN 母座 L=7.60 CH=2.18 墊高0.60 板上四腳插 端子SMT PJ. NO.: UC.01.51-11-0061 SIZE: A4 DRW NO.: FINISH: SEE NOTES MAT'L.: SEE NOTES SCALE: N/A REV.: AO UNIT: mm PAGE: 3/3	
APPD.	JM_Zheng				
CHKD.	LYX				
PDWG.NO:	0100-2	DR.	TSP		