

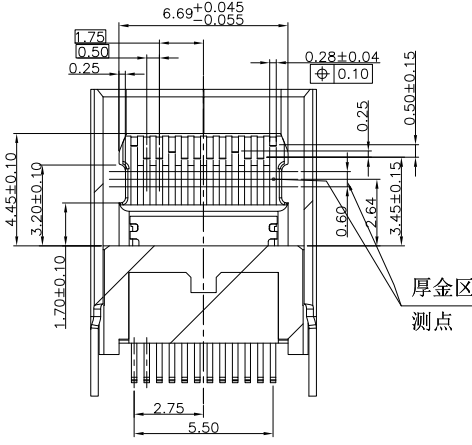

REV.	DESCRIPTION	NAME	DATE
A	NEWS ISSUE		

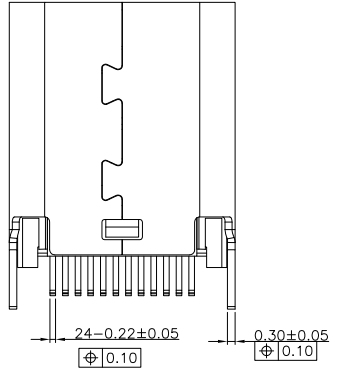

SECTION B-B
SCALE 1:1

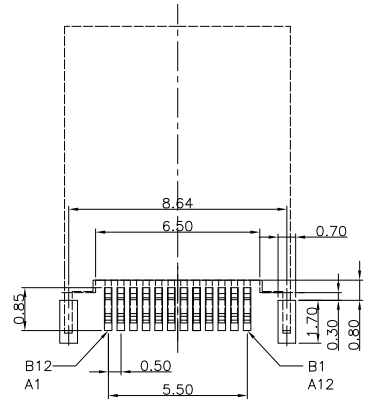

RECOMMENDED P.C.B. LAYOUT (T:1.00mm)
TOLERANCE UNSPECIFIED ±0.05mm

- NOTES:
- MATERIAL:
MOLDING: LCP UL94 V-0
CONTACT: COPPER ALLOY.
PLATED SEE NOTE.

SHELL: SUS304-H, T=0.30±0.03mm
50u" NICKEL PLATING OVER ALL.
SHILD: SUS304-H, T=0.12±0.03mm
 - MECHANICAL:
INSERTION: 5~20N.
EXTRACTION: 8~20N.
DURABILITY: 10000 CYCLES
 - ELECTRICAL:
CURRENT: 5A MAX FOR VBUS;
1.25A MAX FOR OTHER.
VOLTAGE: 20VDC MAX
WITHSTANDING VOLTAGE: 100V AC.
CONTACT RESISTANCE: 40mΩ MAX.
INSULATION RESISTANCE: 100MΩ MIN.
 - ENVIRONMENTAL
TEMPERATURE RANGE: -30° C TO +80° C

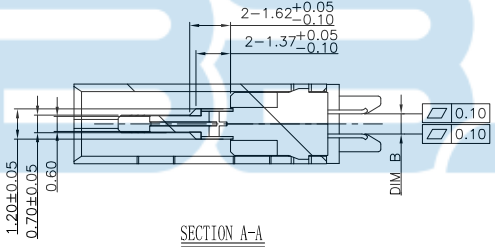
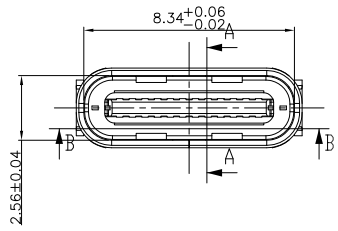

SECTION A-A
SCALE 1:1

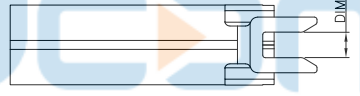

NO	DIM A	DIM B	NO	DIM A	DIM B
1	10.5	0.8	7	8.8	1.0
2	9.3	0.8	8	10.0	1.0
3	8.8	0.8	9	10.5	1.2
4	10.0	0.8	10	9.3	1.2
5	10.5	1.0	11	8.8	1.2
6	9.3	1.0	12	10.0	1.2

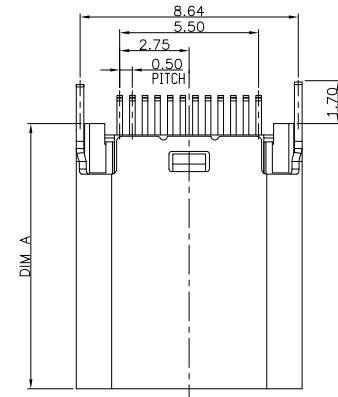

USB TYPE-C FULL-FEATURED RECEPTACLE INTERFACE PIN ASSIGNMENTS

PIN	Signal Name	Description	PIN	Signal Name	Description
A1	GND	Ground return	B12	GND	Ground return
A2	SSTXp1	Positive half of first SuperSpeed TX differential pair	B11	SSRXp1	Positive half of first SuperSpeed RX differential pair
A3	SSTXm1	Negative half of first SuperSpeed TX differential pair	B10	SSRXm1	Negative half of first SuperSpeed RX differential pair
A4	Vbus	Bus Power	B9	Vbus	Bus Power
A5	CC1	Configuration Channel	B8	SRB2	Sideband Use (SRB)
A6	dp1	Positive half of the USB 2.0 differential pair-Position 1	B7	dm2	Negative half of the USB 2.0 differential pair-Position 2
A7	dm1	Negative half of the USB 2.0 differential pair-Position 1	B6	dp2	Positive half of the USB 2.0 differential pair-Position 2
A8	SRB1	Sideband Use(SRB)	B5	CC2	Configuration Channel
A9	Vbus	Bus Power	B4	Vbus	Bus Power
A10	SSRXm2	Negative half of second SuperSpeed RX differential pair	B3	SSTXm2	Negative half of second SuperSpeed TX differential pair
A11	SSRXp2	Positive half of second SuperSpeed RX differential pair	B2	SSTXp2	Positive half of second SuperSpeed TX differential pair
A12	GND	Ground return	B1	GND	Ground return

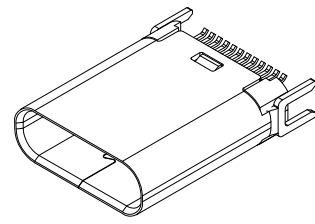

TOLERANCE UNSPECIFIED		0. ±0.38		0.0 ±0.25		0.00 ±0.15		0.0° ±2°		深圳市步步精科技有限公司 TITLE: TYPE-C 24PIN 母座 夹板0.8 H=9.3	
DRAWN/ DATE	设计	TSP	SIZE:A4	UNIT:MM.	PART. NO: UC.01.72-4W-0002						
CHECKED/ DATE	审核	LYX	SCALE: 1:1		PROJECTION			REV.: 版本			
APPROVED/ DATE	核准	LJP	DWG.	PATH	0228-1		SHEET: 页码				



REV.	DESCRIPTION	NAME	DATE
A	NEWS ISSUE		

一. 將成品依同一方向放入真空盤內, 如圖所示.

At same direction, put product onto the tray. Direction refers to below drawing.

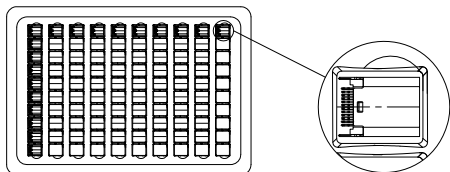

VIEW-1

- 二.
- 1) 一只紙箱可放置之包裝盤(包括上蓋)見下表.
1) trays per carton, please see next table.
 - 2). 每1個紙箱用的包裝數量詳見下表.
2) The Q'ty of products per carton please see next tabel.
 - 3) 將裝滿成品的真空盤用 PE帶捆緊後放在塑膠袋內, 裝完後再封箱.
3) Bind the trays with PE tape and then, put them into the poly bag. Seal the carton with tape.

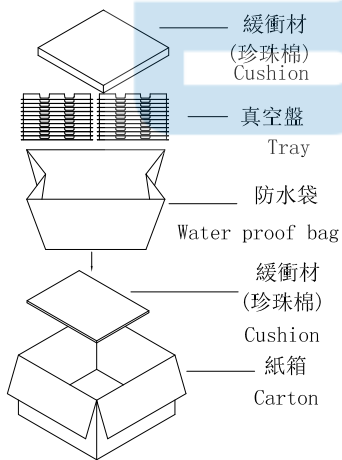

VIEW-2

三.

- 1). 將標籤貼於紙箱側麥上方.
Stick the needful label On the up-right corner of the side of carton.

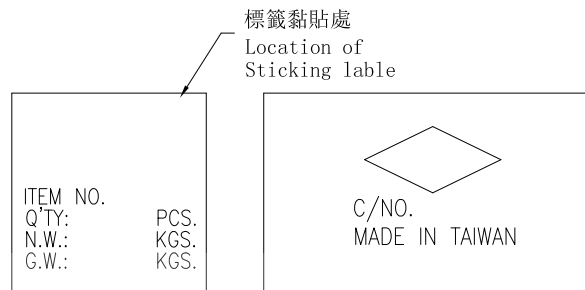

VIEW-3



備 註 (REMARK)

1. 若有未裝滿之零數箱, 必須以緩衝材塞滿.
The unfilling-carton must be filled with assuagement.
2. 防水袋需用膠帶貼實且封口.
waterproof plastic bag must be folded up.
3. 裝滿成品后之外箱, 最大堆積箱數: 5箱
About the box fully filled with products, the MAX accumulating quantity of boxes is 5.
4. 如須貼Bar-code, 請依Bar-code作業辦法執行
If barcode lable is required, do it according to the related barcode lable operation standards.



包裝明細表 (The detail of the packing)						
包裝容量 (Packing Capacity)			重量 Weight (Kg)			
pcs/box	boxs/Carton	Pcs/Box	N.W./Pcs	N.W./Box	G.W./Box	
100	80	8000				

TOLERANCE UNSPECIFIED		深圳市步步精科技有限公司 TITLE: TYPE-C 24PIN 母座 夾板0.8 H=9.3					
	0. ±0.38	SIZE:A4	UNIT:MM.	PART. NO: UC.01.72-4W-0002			
	0.0 ±0.25	CHECKED/ DATE	设计 TSP	SCALE: 1:1	PROJECTION	REV.: 版本	
	0.00 ±0.15	CHECKED/ DATE	审核 LYX	DWG. PATH	0228-1	SHEET: 页码	
	0.0° ±2°	APPROVED/ DATE	核准 LJP				