

REV.	ECN NO	CONTENT	DATE	ENGINEER
A0		Initial release	/	TSP

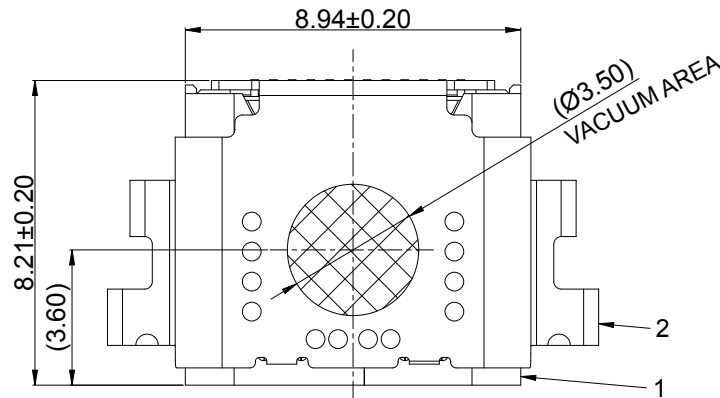

- NOTE/注释:
- SPECIFICATION/规格:
    - Rated current (额定电流): 5.0 A
    - Voltage rating (额定电压): 5V AC
    - Contact Resistance (接触阻抗): 40 mΩ Max.
    - Insulation Resistance (绝缘阻抗): 100MΩ Min.
    - Withstanding voltage (耐电压): 100 VAC/minute
    - Mating force (插入力): 5~20N .
    - Unmating force (拔出力): 8~20N.
    - Durability Cycle(寿命循环):10,000 cycle
    - Operating temperature (工作温度): -40°~+85°

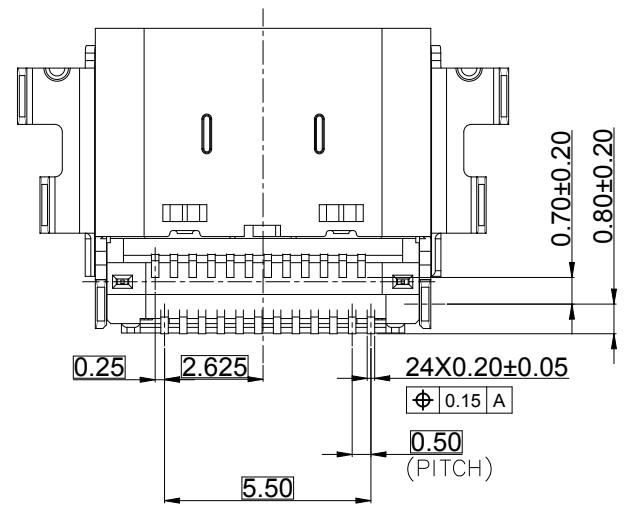
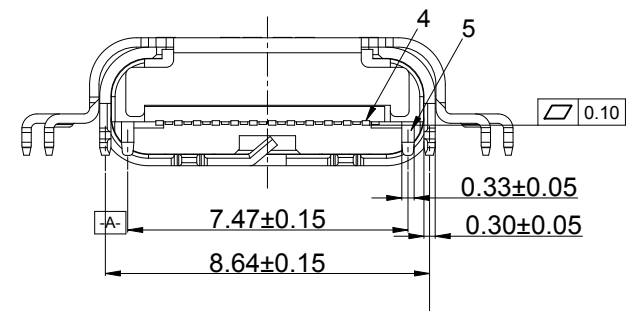
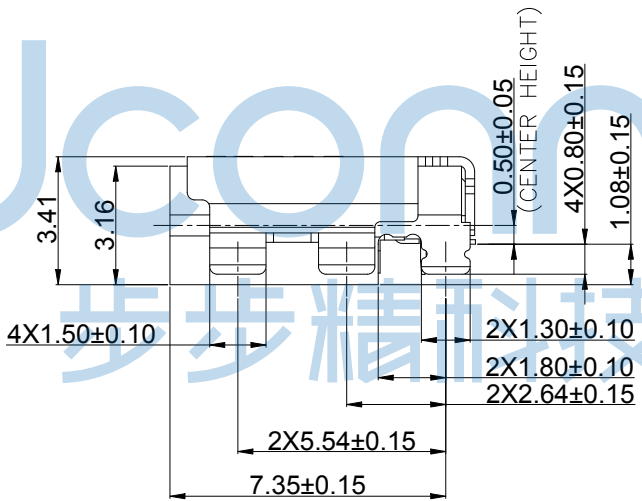
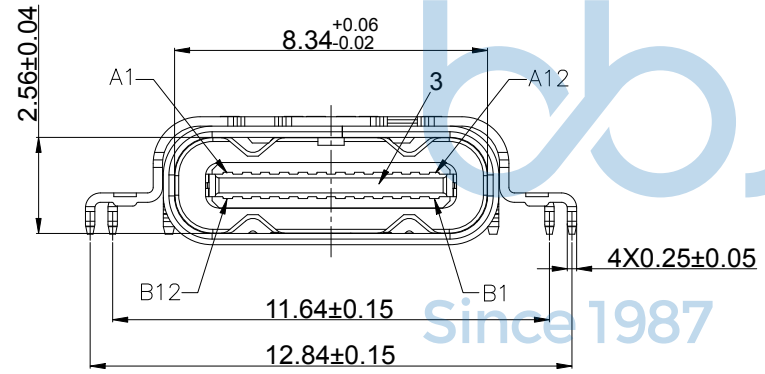

ITEM	DESCRIPTION	QTY	MATERIAL	FINISH	REMARK
5	MID PLATE	1	SUS301	NICKEL PLATING	T=0.15
4	TERMINAL	24	C18140	MATING SIDE: Au 30u"MIN; SOLDER TAIL: Gold FLASH, 50u" NICKEL OVERALL.	T=0.12
3	MAIN HOUSING	1	PA9T HF 30%玻纤, UL94 V-0, 黑色		BLACK UL94V-0
2	OUT SHELL	1	SUS304	NICKEL PLATING	T=0.25
1	MAIN SHELL	1	SUS304	NICKEL PLATING	T=0.30

THIS DOCUMENT IS THE SOLE PROPERTY OF BBJconn Technology Co.,Ltd. Corporation AND SHOULD NOT BE USED IN WHOLE OR IN PART WITHOUT PRIOR WRITTEN PERMISSION.

PDWG.NO: 0470-1

DR. TSP

APPD. JM\_Zheng

CHKD. LYX

NAME: TYPE-C 24P 母座 有后盖 双壳 六脚插 端子双排SMT 沉板1.08 L=8.21 CH=0.50 编带

PJ. NO.: UC.01.32-2W-0001

SIZE: A4 DRW NO.:

FINISH: SEE NOTES MAT'L.: SEE NOTES

SCALE: N/A REV.: A0 UNIT: mm PAGE: 1/3





REV.	ECN NO	CONTENT	DATE	ENGINEER
A0		Initial release	/	TSP

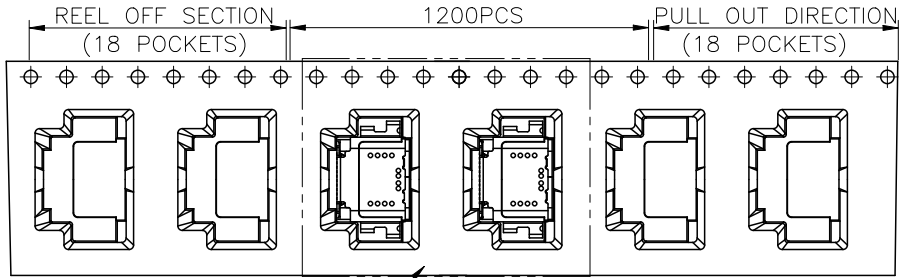

SEE DETAIL X

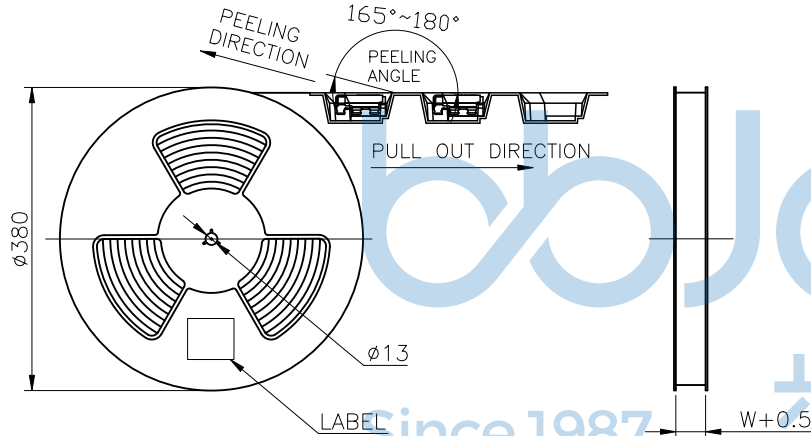

PAPER BOARD

REEL AND TAPE

REEL AND TAPE

PAPER BOARD

FOLDER PAPER BOARD

CARTON

PULL OUT DIRECTION

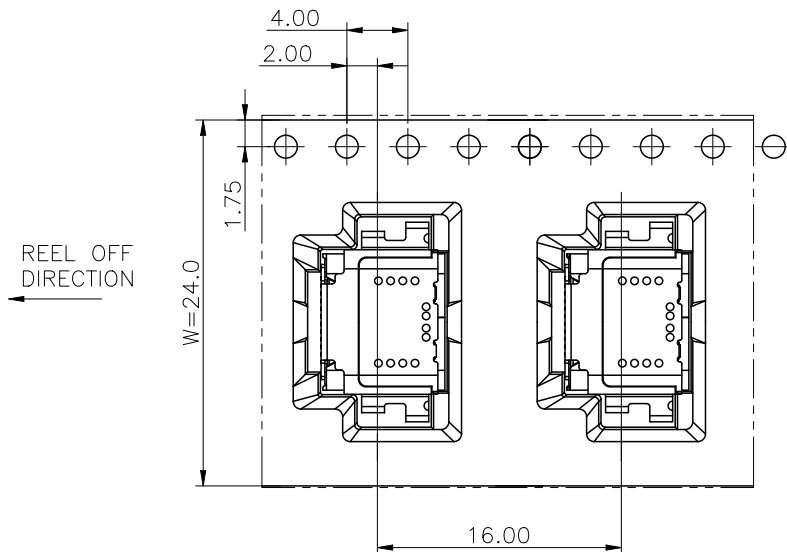

	REEL	CARTON
CONNECTOR (PCS)	1200	12000

THIS DOCUMENT IS THE SOLE PROPERTY OF BBJconn Technology Co.,Ltd. Corporation AND SHOULD NOT BE USED IN WHOLE OR IN PART WITHOUT PRIOR WRITTEN PERMISSION.

PDWG.NO: 0470-1

APPD. JM\_Zheng      CHKD. LYX      DR. TSP

深圳市步步精科技有限公司

NAME: TYPE-C 24P 母座 有后盖 双壳 六脚插 端子双排SMT 沉板1.08 L=8.21 CH=0.50 编带

PJ. NO.: UC.01.32-2W-0001      SIZE: A4      DRW NO.:

FINISH: SEE NOTES      MAT'L.: SEE NOTES

SCALE: N/A      REV.: A0      UNIT: mm      PAGE: 3/3