

REV.	ECN NO	CONTENT	DATE	ENGINEER
A0			2023 20/04	

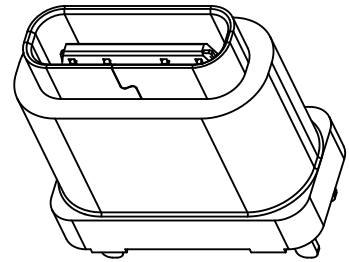

RECOMMENDED P. C. B. LAYOUT (T: 1.00mm)  
TOLERANCE UNSPECIFIED ±0.05mm

- NOTE:
- MATERIAL SPECIFICATION:
    - HOUSING: LCP E130i, UL94V-0.
    - SHELL HOUSING: NY 9T, UL94V-0.
    - CONTACTS: C7025 or C2680
    - MID PLATE: SUS301
    - FRONT SHELL: SUS304
  - PLATING SPECIFICATION:
    - CONTACTS:
      - Ni 50u" MIN. UNDER PLATED OVER ALL.
      - Au PLATED ON THE FUNCTIONAL AREA OF CONTACT.
      - (GOLD PLATING THICKNESS FOLLOW THE P/N)
    - FRONT SHELL:
      - Ni 30u" MIN. UNDER PLATED OVER ALL.
    - MID PLATE:
      - CLEAR ONLY
  - MECHANICAL PERFORMANCE,
    - INSERTION FORCE: 0.5~2.0kgf.
    - REMOVAL FORCE: 0.8kgf~2.0kgf.
    - DURABILITY: 10000 CYCLES.
  - ELECTRICAL PERFORMANCE,
    - CURRENT RATING: 5.0A  
VOLTAGE RATING: 5.0V
    - LLCR:
      - VBUS & GND PINS AND OTHER PINS: 40mΩ/PIN MAX.
      - SHIELD: 50mΩ/MAX.
    - INSULATION RESISTANCE: 100MΩ MIN
    - DIELECTRIC WITHSTAND VOLTAGE, AC 100V FOR 1 MINUTE.
  - ENVIRONMENTAL PERFORMANCE:
    - OPERATING TEMPERATURE: -25°C~+85°C.
    - THE PEAK TEMPERATURE ON THE BOARD SHALL BE MAINTAINED FOR 10 SECONDS AT 260°C.
  - WATER PROOFNESS: THIS PRODUCT IS BASED ON IPX7.

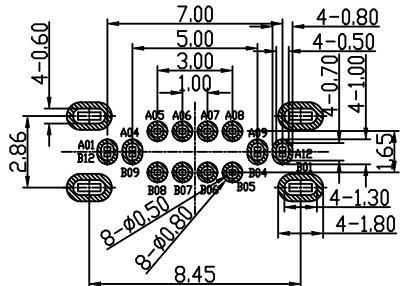
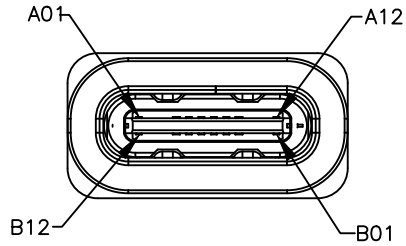
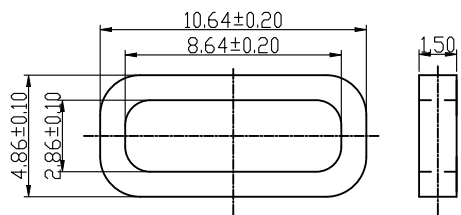
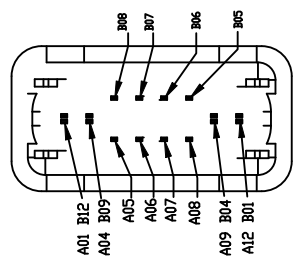
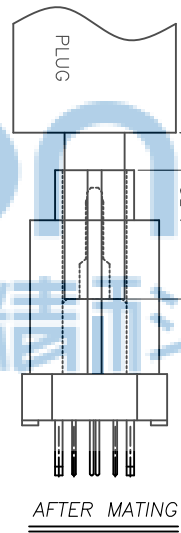
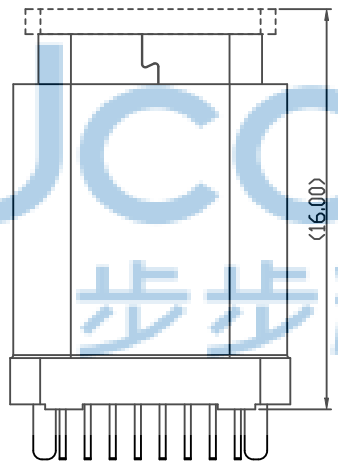
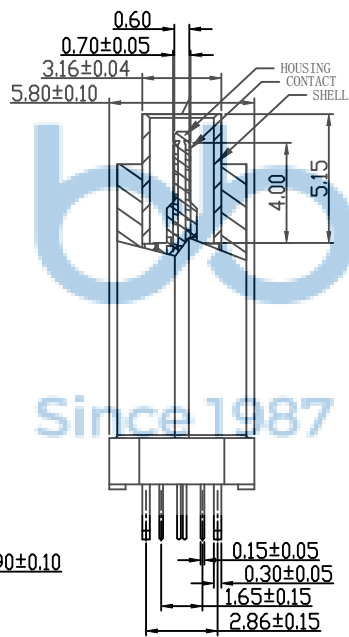
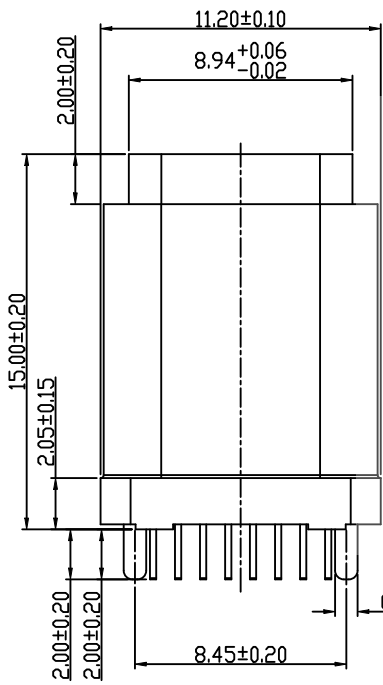

PIN NUMBER	A1	A2	A3	A4	A5	A6	A7	A8	A9	A10	A11	A12
SIGNAL NAME	GND			V <sub>bus</sub>	CC1	Dp1	Dn1	SBU1	V <sub>bus</sub>			GND
PIN NUMBER	B12	B11	B10	B9	B8	B7	B6	B5	B4	B3	B2	B1
SIGNAL NAME	GND			V <sub>bus</sub>	SBU2	Dn2	Dp2	CC2	V <sub>bus</sub>			GND

THIS DOCUMENT IS THE SOLE PROPERTY OF BBJconn Technology Co., Ltd. Corporation AND SHOULD NOT BE USED IN WHOLE OR IN PART WITHOUT PRIOR WRITTEN PERMISSION.		深圳市步步精科技有限公司 工程 部	
.X: ±0.38    .XX: ±0.25    .XXX: ±0.13 X*: ±3"    .X*: ±2"    .XX*: ±1"		NAME: TYPE-C 16P 防水母座 180度 H=15.0 全插 (DIP) IPX7 APPD. JM_Zheng CHKD. TSP DR. LYX	
PDWG.NO: 9999-99		PJ. NO.: UC.01.11-1N-0003 SIZE: A4 DRW NO.: FINISH: SEE NOTES    MAT'L.: SEE NOTES SCALE: N/A    REV.: A3    UNIT: mm    PAGE: 1/2	

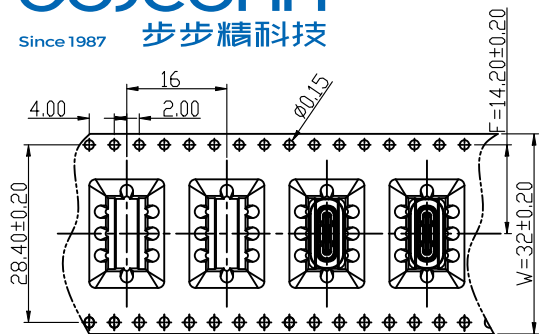

① 产品入载带示意图

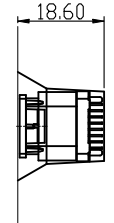

② 卷盘贴标签示意图

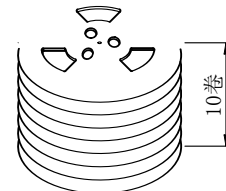
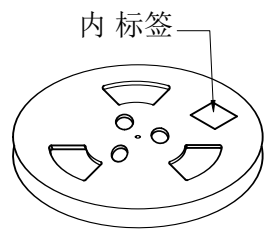

③ 10盘产品叠层示意图

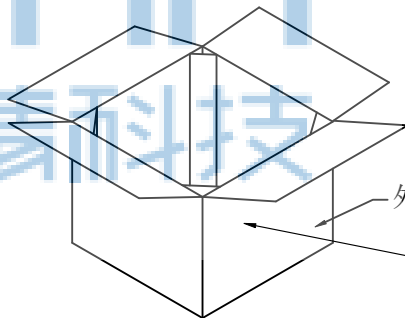
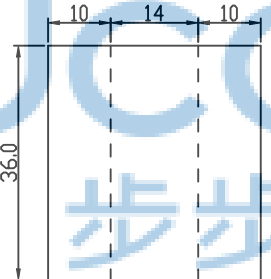

④ 产品入外箱示意图

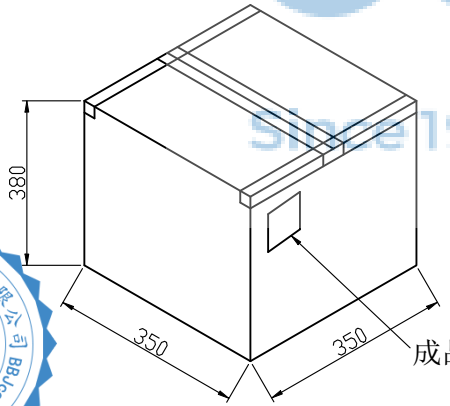

⑤ 外箱封箱示意图



正唛侧唛图示:

ITEM NO:			
QTY:		PCS	
N. W		KGS	
G. W:		KGS	
MEAS: 35X35X38CM			

包装说明:

- 将检验好的成品;插板脚朝下放入载带底部;每卷装200PCS产品;具体如图一所示
- 将包装好的产品;每盘必需贴上内标签;具体如图二所示
- 将贴好内标签的产品每10盘叠;具体如图三所示
- 装好后并封好纸箱及贴好相关标签;具体如图五所示;  
(产品包装的标签,如客户有要求,请按客户要求包装出货)
- 载带前面留14PCS空格,后面留14PCS空格
- COVER与CARRY剥离力:50-125g,速度:300mm/分钟左右,剥离角度:165°-180°

THIS DOCUMENT IS THE SOLE PROPERTY OF BBJconn Technology Co.,Ltd. Corporation AND SHOULD NOT BE USED IN WHOLE OR IN PART WITHOUT PRIOR WRITTEN PERMISSION.		深圳市步步精科技有限公司 .X: ±0.38    .X': ±3" .XX: ±0.25    .X'': ±2" .XXX: ±0.13    .XX': ±1"	
APPD.	JM_Zheng	NAME: TYPE-C 16P 防水母座 180度 H=15.0 全插 (DIP) IPX7	
CHKD.	TSP	PJ. NO.: UC.01.11-1N-0003	
DR.	LYX	SIZE: A4   DRW NO.:	
PDWG.NO:	9999-99	FINISH: SEE NOTES    MAT'L.: SEE NOTES	
		SCALE: N/A    REV.: A3    UNIT: mm    PAGE: 2/2	