

REV.	ECN NO	CONTENT	DATE	ENGINEER
A0				

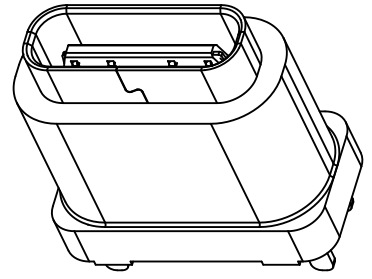

RECOMMENDED P. C. B. LAYOUT (T:1.00mm)
TOLERANCE UNSPECIFIED ±0.05mm

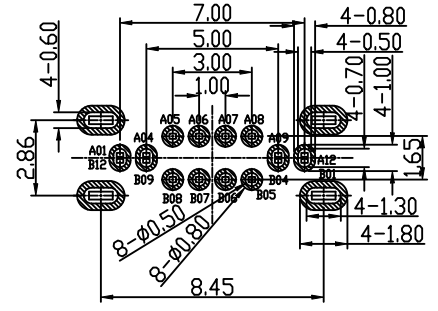
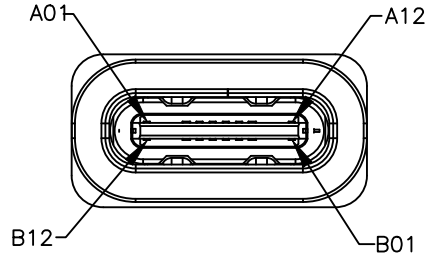
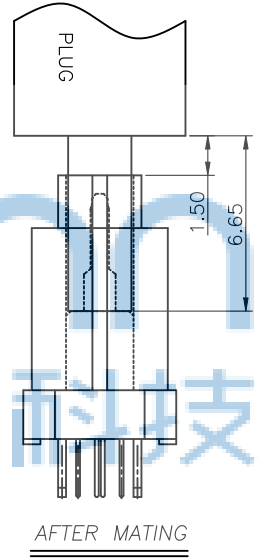
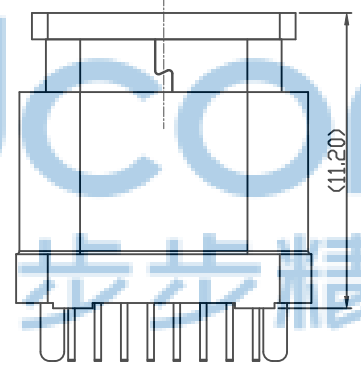
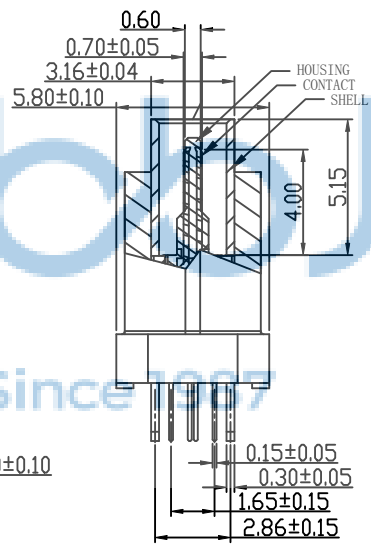
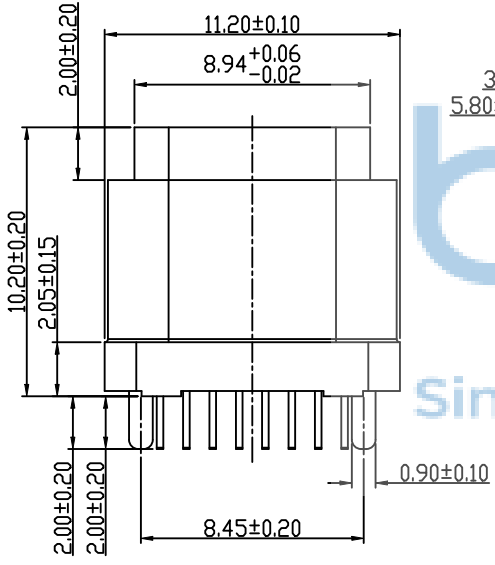

AFTER MATING

- NOTE:
- MATERIAL SPECIFICATION:
 - HOUSING: LCP, UL94V-0.
 - SHELL HOUSING: NY 9T, UL94V-0.
 - CONTACTS: C7025 or C2680
 - MID PLATE: SUS301
 - FRONT SHELL: SUS304
 - PLATING SPECIFICATION:
 - CONTACTS:
 - Ni 50u" MIN. UNDER PLATED OVER ALL.
 - Au PLATED ON THE FUNCTIONAL AREA OF CONTACT. (GOLD FLASH PLATING ON CONTACT AREA)
 - FRONT SHELL:
 - Ni 30u" MIN. UNDER PLATED OVER ALL.
 - MID PLATE:
 - CLEAR ONLY
 - MECHANICAL PERFORMANCE:
 - INSERTION FORCE: 0.5~2.0kgf.
 - REMOVAL FORCE: 0.8kgf~2.0kgf.
 - DURABILITY: 10000 CYCLES.
 - ELECTRICAL PERFORMANCE:
 - CURRENT RATING: 5.0A
VOLTAGE RATING: 5.0V
 - LLCR:
 - VBUS & GND PINS AND OTHER PINS: 40mΩ/PIN MAX.
 - SHIELD: 50mΩ/MAX.
 - INSULATION RESISTANCE: 100MΩ MIN
 - DIELECTRIC WITHSTAND VOLTAGE, AC 100V FOR 1 MINUTE.
 - ENVIRONMENTAL PERFORMANCE:
 - OPERATING TEMPERATURE: -25°C~+85°C.
 - THE PEAK TEMPERATURE ON THE BOARD SHALL BE MAINTAINED FOR 10 SECONDS AT 260°C.
 - WATER PROOFNESS: THIS PRODUCT IS BASED ON IPX7.

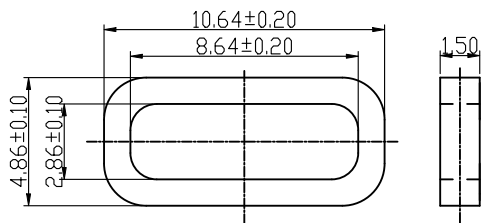
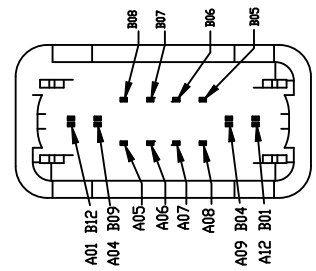

PIN NUMBER	A1	A2	A3	A4	A5	A6	A7	A8	A9	A10	A11	A12
SIGNAL NAME	GND			V _{BUS}	CC1	Dp1	Dn1	SBU1	V _{BUS}			GND
PIN NUMBER	B12	B11	B10	B9	B8	B7	B6	B5	B4	B3	B2	B1
SIGNAL NAME	GND			V _{BUS}	SBU2	Dn2	Dp2	CC2	V _{BUS}			GND

THIS DOCUMENT IS THE SOLE PROPERTY OF BBJconn Technology Co., Ltd. Corporation AND SHOULD NOT BE USED IN WHOLE OR IN PART WITHOUT PRIOR WRITTEN PERMISSION.

PDWG. NO: 9999-99

深圳市步步精科技有限公司

APPROVED

APPD. JM_Zheng

CHKD. TSP

DR. LYX

NAME: TYPE-C 16P 防水母座 180度 H=10.2 全插 (DIP) IPX7 方形防水圈

PJ. NO.: UC.01.11-1W-0004

SIZE: A4 | DRW NO.:

FINISH: SEE NOTES | MAT'L.: SEE NOTES

SCALE: N/A | REV.: A0 | UNIT: mm | PAGE: 1/2

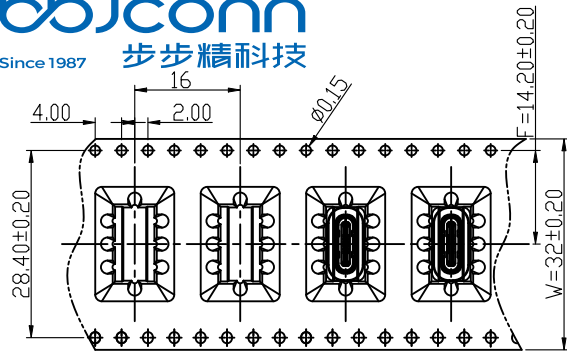

① 产品入载带示意图

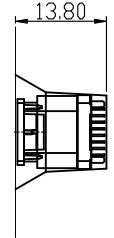

② 卷盘贴标签示意图

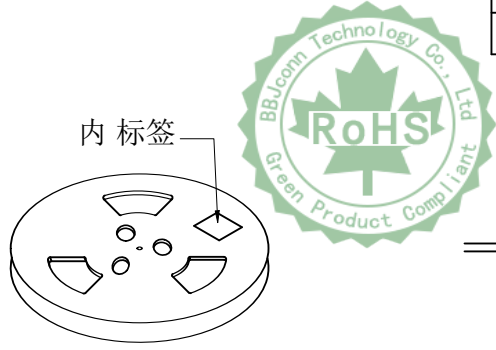

③ 10盘产品叠层示意图

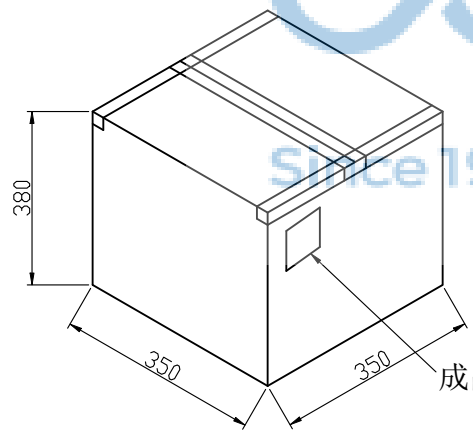
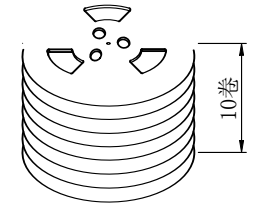

⑤ 外箱封箱示意图

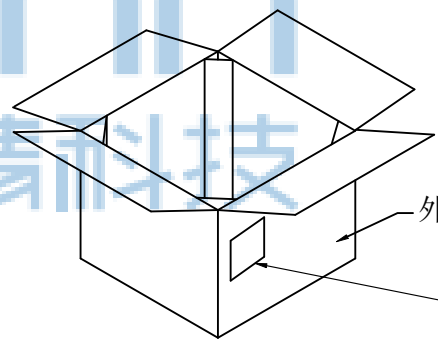
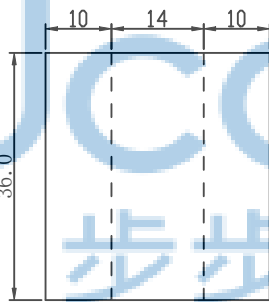

④ 产品入外箱示意图

正唛侧唛图示:

ITEM NO:			
QTY:		PCS	
N. W		KGS	
G. W:		KGS	
MEAS: 35X35X38CM			



- 包装说明:
- 将检验好的成品;插板脚朝下放入载带底部;每卷装300PCS产品;具体如图一所示
 - 将包装好的产品;每盘必需贴上内标签;具体如图二所示
 - 将贴好内标签的产品每10盘叠;具体如图三所示
 - 装好后并封好纸箱及贴好相关标签;具体如图五所示;
(产品包装的标签,如客户有要求,请按客户要求包装出货)
 - 载带前面留12PCS空格,后面留12PCS空格
 - COVER与CARRY剥离力:50-125g,速度:300mm/分钟左右,剥离角度:165°-180°

THIS DOCUMENT IS THE SOLE PROPERTY OF BBJconn Technology Co., Ltd. Corporation AND SHOULD NOT BE USED IN WHOLE OR IN PART WITHOUT PRIOR WRITTEN PERMISSION.		深圳市步步精科技有限公司 APPD. JM_Zheng CHKD. TSP DR. LYX PDWG.NO: 9999-99		NAME: TYPE-C 16P 防水母座 180度 H=10.2 全插 (DIP) IPX7 方形防水圈 PJ. NO.: UC.01.11-1W-0004 SIZE: A4 DRW NO.: FINISH: SEE NOTES MAT'L.: SEE NOTES SCALE: N/A REV.: A0 UNIT: mm PAGE: 2/2	
---	--	--	--	--	--