

REV.	ECN NO.	CONTENT	DATE	ENGINEER
A0		Initial release	/	SGF

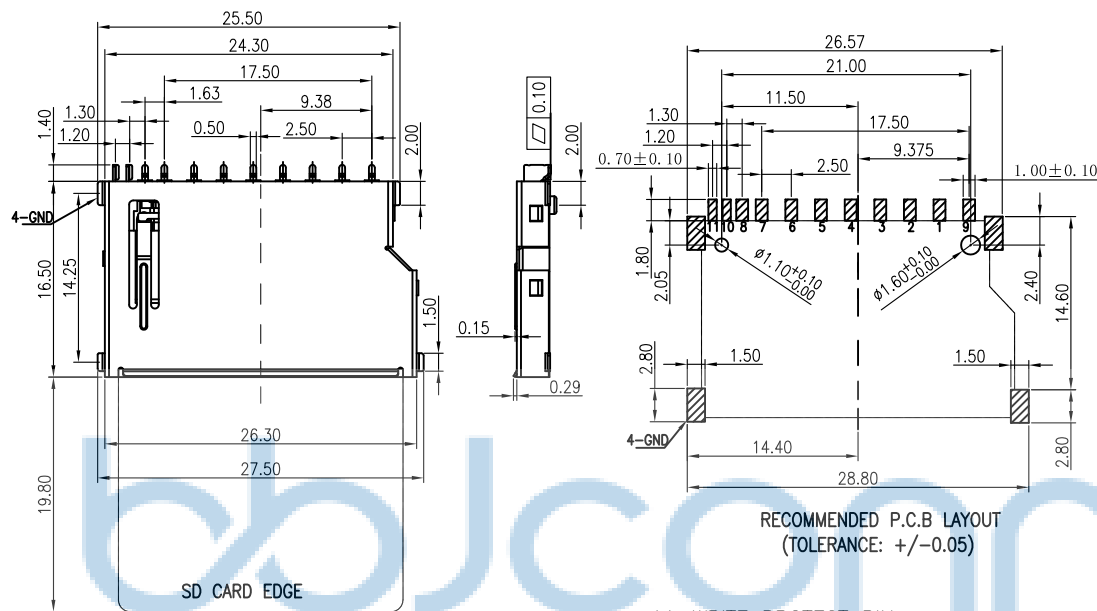

11-WRITE PROTECT PIN
10-CARD DETECT PIN
GROUND(SHELL)-COMMON PIN

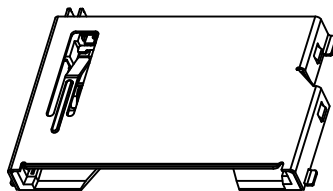
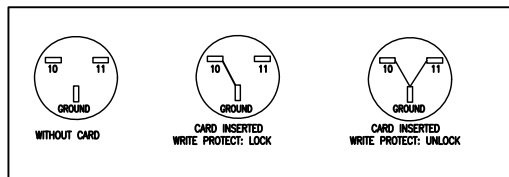
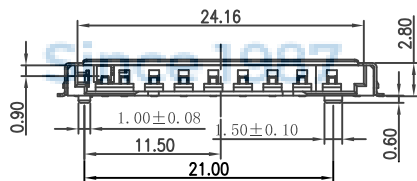

- NOTES:
- MATERIAL**
HOUSING : HIGH TEMPERATURE THERMOPLASTIC.
CONTACT: COPPER ALLOY
SHELL: COPPER ALLOY
 - PLATING**
CONTACT AREA: GOLD PLATED OVER Ni
SOLDER TAIL: 50~100u²MIN Sn PLATED OVER Ni
SHELL SOLDER AREA: NICKEL PLATED
 - RATING**
CURRENT RATING: 0.5A
VOLTAGE RATING: 250VRMS
OPERATING TEMPERATURE: -25°C~90°C
 - SPECIFICATION**
CONTACT RESISTANCE: 100 M OHMS MAX
DIELECTIC WITHSTANDING VOLTAGE: 500VAC 1Min.
INSULATION RESISTANCE: 1000 MegOHMS MIN
INSERTION FORCE: 40N MAX
SEPARATION FORCE: 1-10N

SD CARD PIN DESIGN

PIN NO.	NAME	DESCRIPTION
1#	CD/DAT3	CARD DETECT/DATA I/O
2#	CMD	COMMAND
3#	VSS1	GROUND
4#	VDD	POWER
5#	CLK	CLOCK
6#	VSS2	GROUND
7#	DAT0	DATA I/O
8#	DAT1	DATA I/O
9#	DAT2	DATA I/O
10#	CD	
11#	WP	



THIS DOCUMENT IS THE
SOLE PROPERTY OF
BBJconn Technology Co., Ltd.
Corporation AND SHOULD
NOT BE USED IN WHOLE
OR IN PART WITHOUT
PRIOR WRITTEN PERMISSION.
PDWG.NO: 0302-1

深圳市步步精科技有限公司

NAME: SD 11P H2.8 短体卡座 黑胶 全贴 带柱

APPD. JM_Zheng

CHKD. LYX

DR. SGF

PJ. NO.: 142-312-110001-V8G

SIZE: A4 DRW NO.:

FINISH: SEE NOTES MAT'L.: SEE NOTES

SCALE: N/A REV.: A0 UNIT: mm PAGE: 1/2

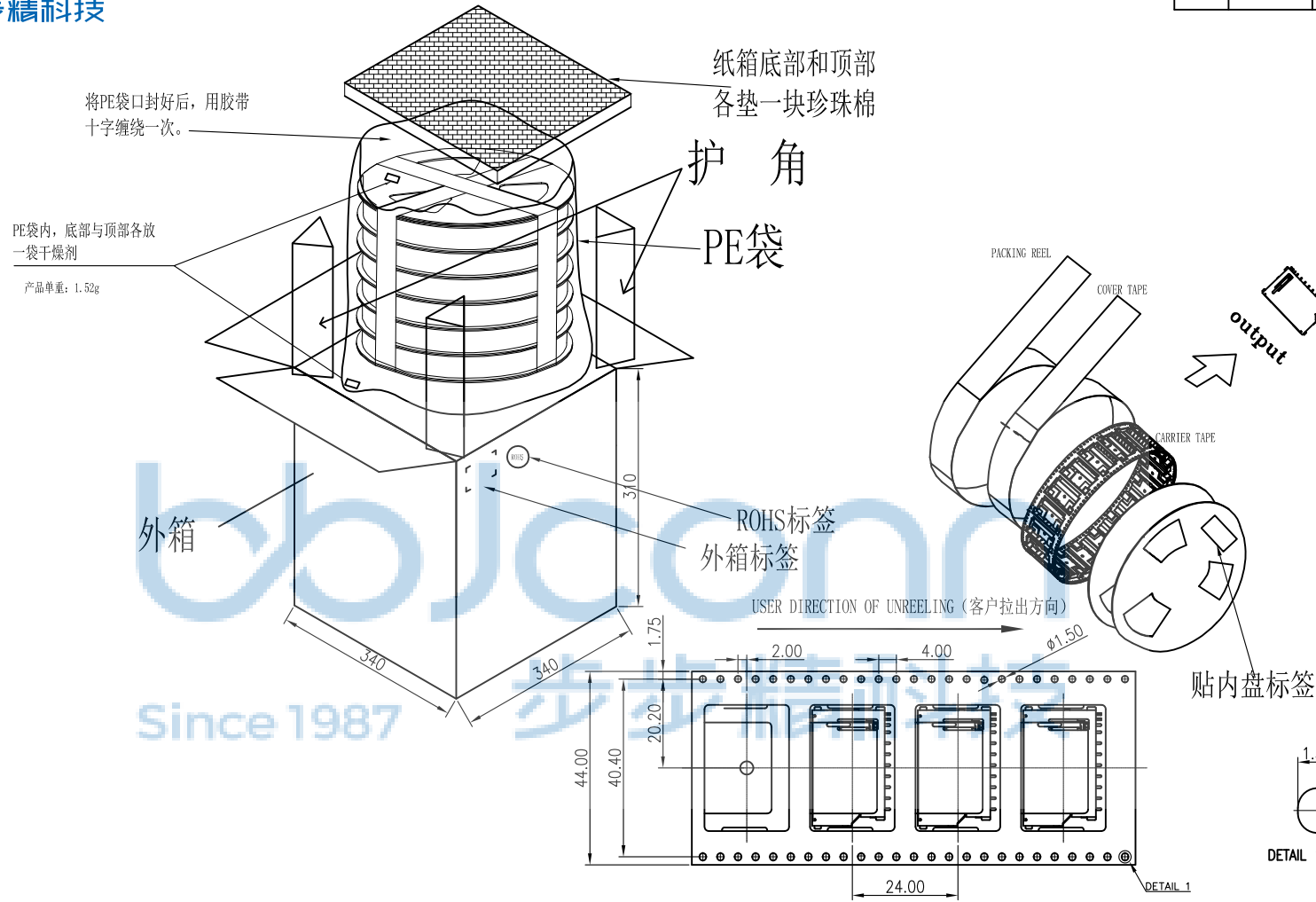

- NOTE:**
- 每卷CARRIER TAPE 前后各留10PCS以上不使用
DON'T USE IN FRONT AREA OF 10PCS AND IN END AREA OF 10PCS ON EACH CARRIER TAPE.
 - 每卷CARRIER TAPE放置600个SD CONNECTOR.
EACH CARRIER TAPE ROLL PUT 600 PCS SD CONNECTOR
 - 每6卷CARRIER TAPE 用1个PE BAG
EVERY SIX CARRIERS TAPE USE ONE PE BAG
 - 以COVER TAPE覆盖后, 经包装机冷封包装
USE COVER TAPE TO COVER AND COLD MACHINE TO SEAL UP
 - 以PSA COVER PLATE覆盖于外面再以胶带固定
THE OUTSIDE OF THE ROLL USE PSA COVER PLATE TO COVER AND USE ADHESIVE TAPE TO FIX
 - 放入CARTON并以胶带封口
PUT ROLL IN THE CARTON AND USE ADHESIVE TAPE TO SEAL UP
 - CARTON 之麦头贴法请参考生管资料
THE MARK WILL BE PROVIDED BY PMC
 - 在OUTSIDE CARTON外侧如图所示位置贴标签
STAMP ROHS LABEL ON THE CARTON.
 - 产品单重1.52g
CONNECTOR WEIGHT: 1.52G/PCS

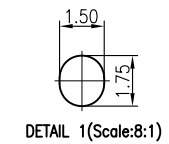

NO.	MATERIAL	UNIT	Q'TY
7	LABEL	PCS	1
6	OUTSIDE CARTON	PCS	1
5	COVER TAPE	M	89.28
4	PACKING REEL	PCS	6
3	PE BAG	PCS	1
2	CARRIER TAPE	SET	6
1	SD CONNECTOR	PCS	3600



THIS DOCUMENT IS THE SOLE PROPERTY OF BBJconn Technology Co., Ltd. CORPORATION AND SHOULD NOT BE USED IN WHOLE OR IN PART WITHOUT PRIOR WRITTEN PERMISSION.		深圳市步步精科技有限公司 NAME: SD 11P H2.8 短体卡座 黑胶 全贴 带柱	
APPD.	JM_Zheng	PJ. NO.: 142-312-110001-V8G	
CHKD.	LYX	SIZE: A4 DRW NO.:	
DR.	SGF	FINISH: SEE NOTES	MAT'L.: SEE NOTES
PDWG.NO:	0302-1	SCALE: N/A	REV.: A0 UNIT: mm PAGE: 2/2