

REV.	ECN NO	CONTENT	DATE	ENGINEER
A0		Initial release	/	TSP

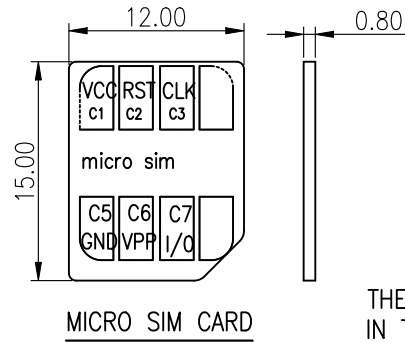
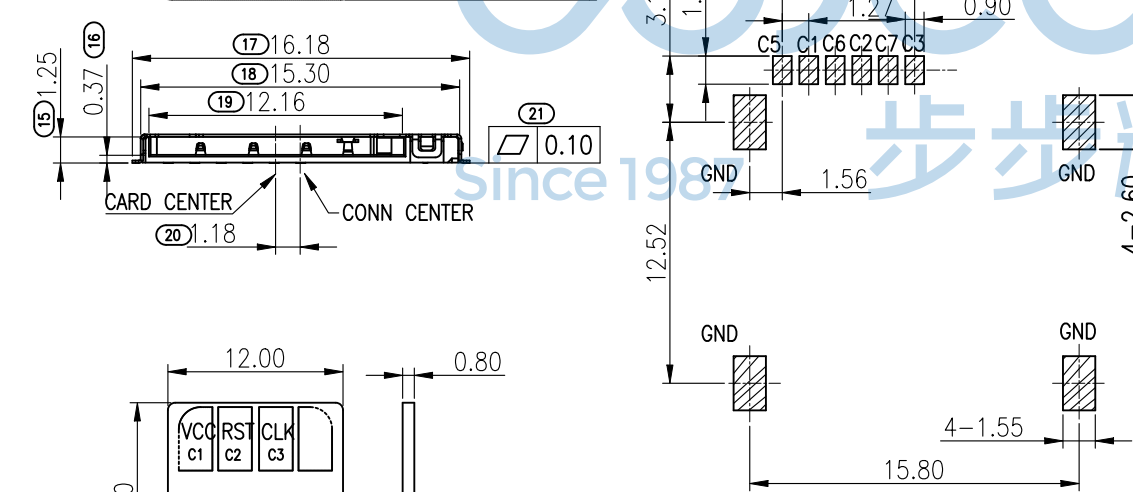
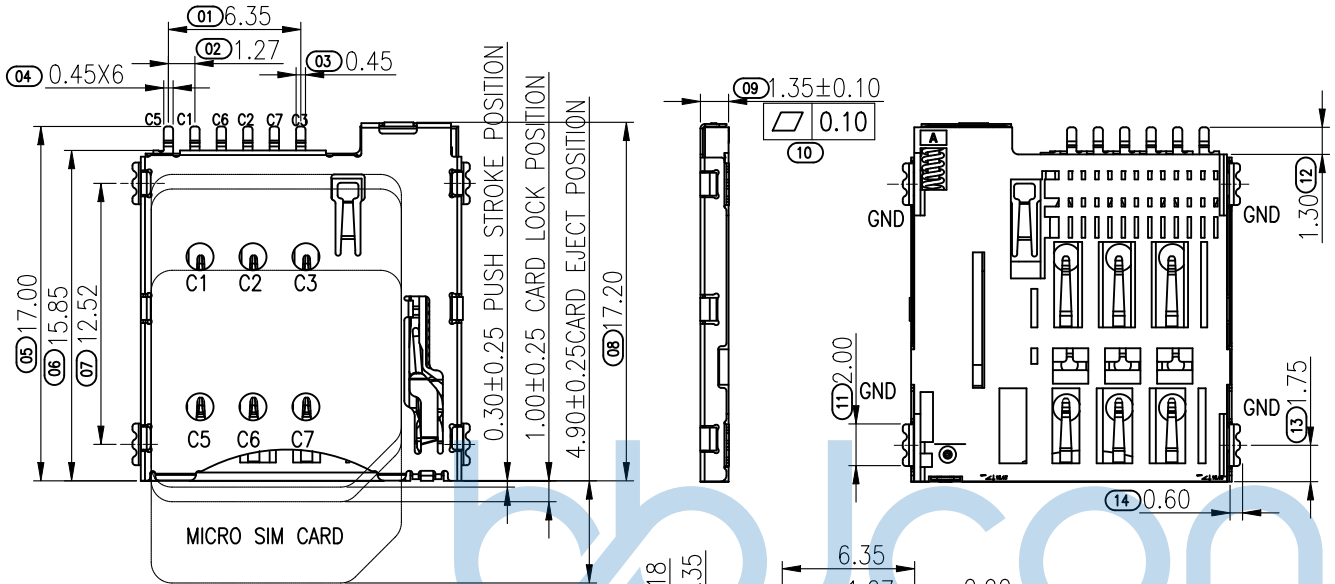

■ CIRCUT TRACE KEEP OUT AREA
■ SMT SOLDER AREA

THERE SHOULD NOT BE ANY CIRCUITRIES IN THE LAYOUT SPACE OF THE PRODUCTS.

RECOMMENDED PCB LAYOUT
GENERAL TOLERANCE ±0.05

SIM pin Assignment	
PIN#	Name
C1	VCC
C2	RST
C3	CLK
C5	GND
C6	VPP
C7	I/O

THIS DOCUMENT IS THE SOLE PROPERTY OF BBJconn Technology Co.,Ltd. CORPORATION AND SHOULD NOT BE USED IN WHOLE OR IN PART WITHOUT PRIOR WRITTEN PERMISSION.
PDWG.NO: 0390-1

深圳市步步精科技有限公司

NAME: 卡座 MICRO SIM CARD 6PIN PUSH PUSH H=1.35 贴片 无柱

APPD. JM_Zheng
CHKD. LYX
DR. TSP

PJ. NO.: 142-201-060001-S4G
SIZE: A4 DRW NO.:
FINISH: SEE NOTES MAT'L.: SEE NOTES
SCALE: N/A REV.: A0 UNIT: mm PAGE: 1/2

NOTES:

MATERIAL:

Insulator: High Temperature Thermoplastic,
Contact: Copper Alloy
Shell: STAINLESS

PLATING:

Contact: Plated 30u" Ni Overall ,Solder Area: Tin,Contact G/F
Shell: Plated 30u" Ni Overall
Plated G/F Selective Contact Area

Electrical:

Current Rating :0.5 A max.
Voltage Rating :50V DC MAX
Ambient Temperature Range : -20°C~+85°C
Storage Temperature Range : -40°C~+70°C
Ambient Humidity Range :95% R.H. Max.
Contact Resistance:100mΩ max.
Insulation Resistance:1000MΩmin./250V DC
Dielectric Withstanding Voltage:500V AC
Mating Cycles:5,000 Insertions
Temperature: 260°C ±5°

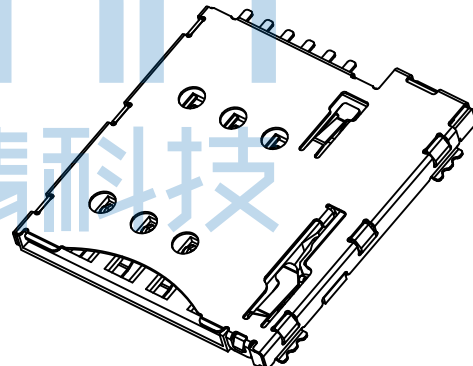

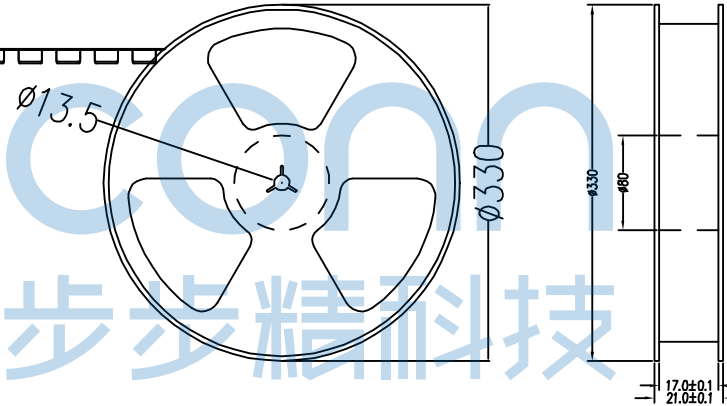
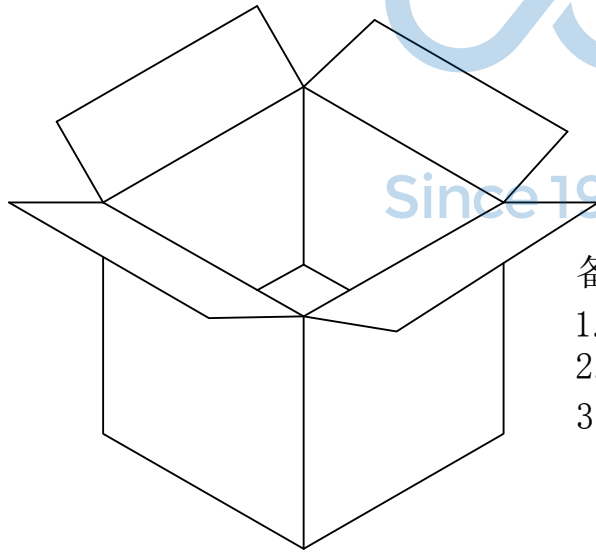
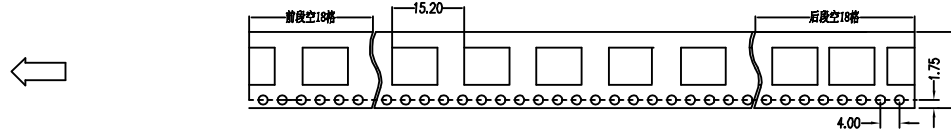
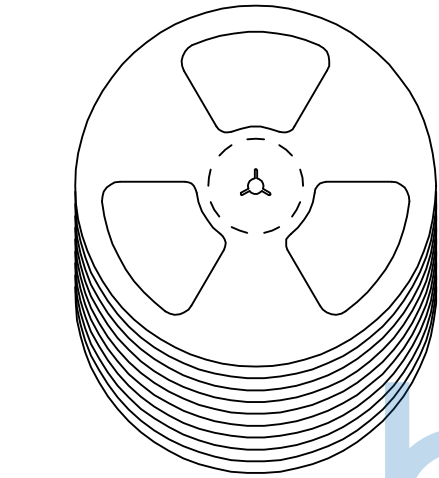

备注:

1. 包装数量: 1000/PCS/卷, 10卷/箱。
2. 包装袋长度: 每卷前后各空10-20个空格, 中间包装。
3. 材质:
载体: 聚丙烯 (PS),
上带: 聚乙烯 (PET),
卷盘: 聚苯乙烯。

纸箱规格: 345*345*23MM

纸箱规格: 345*345*35MM

THIS DOCUMENT IS THE SOLE PROPERTY OF BBJconn Technology Co.,Ltd. Corporation AND SHOULD NOT BE USED IN WHOLE OR IN PART WITHOUT PRIOR WRITTEN PERMISSION.		深圳市步步精科技有限公司 .X: ± 0.38 .XX: ± 0.25 .XXX: ± 0.13 X': $\pm 3'$ X'': $\pm 2'$ XX': $\pm 1'$		NAME: 卡座 MICRO SIM CARD 6PIN PUSH PUSH H=1.35 贴片 无柱	
APPD.	JM_Zheng	PJ. NO.: 142-201-060001-S4G		SIZE: A4 DRW NO.:	
CHKD.	LYX	FINISH: SEE NOTES		MAT'L.: SEE NOTES	
PDWG.NO:	0390-1	DR.	TSP	SCALE: N/A	REV.: A0 UNIT: mm PAGE: 2/2