

NOTE:

1. Electrical
  - 1.1. Rated Voltage: 40V AC/DC maximum
  - 1.2. Rated Current: 0.3A max.
  - 1.3. Dielectric strength: 150V AC/1 minute
  - 1.4. Insulation Resistance: 150V DC 10MΩ min.
2. Mechanical
  - 2.1. Insertion Force Max: 4.5kgf max.
  - 2.2. Removal Force Min: 0.5kgf min. , 2.5kgf max.
  - 2.3. Durability: 5,000 cycles at 100±50 cycles per hour
3. Plating
  - 3.1. Terminal: Contact area: gold plated over 50u" NI min  
Soldered area: 100u" mist TIN plated over 50u" NI min.
  - 3.2. Shell: G/F plated over 50u" NI min.
4. Ambient Temperature: -25° C To +85° C

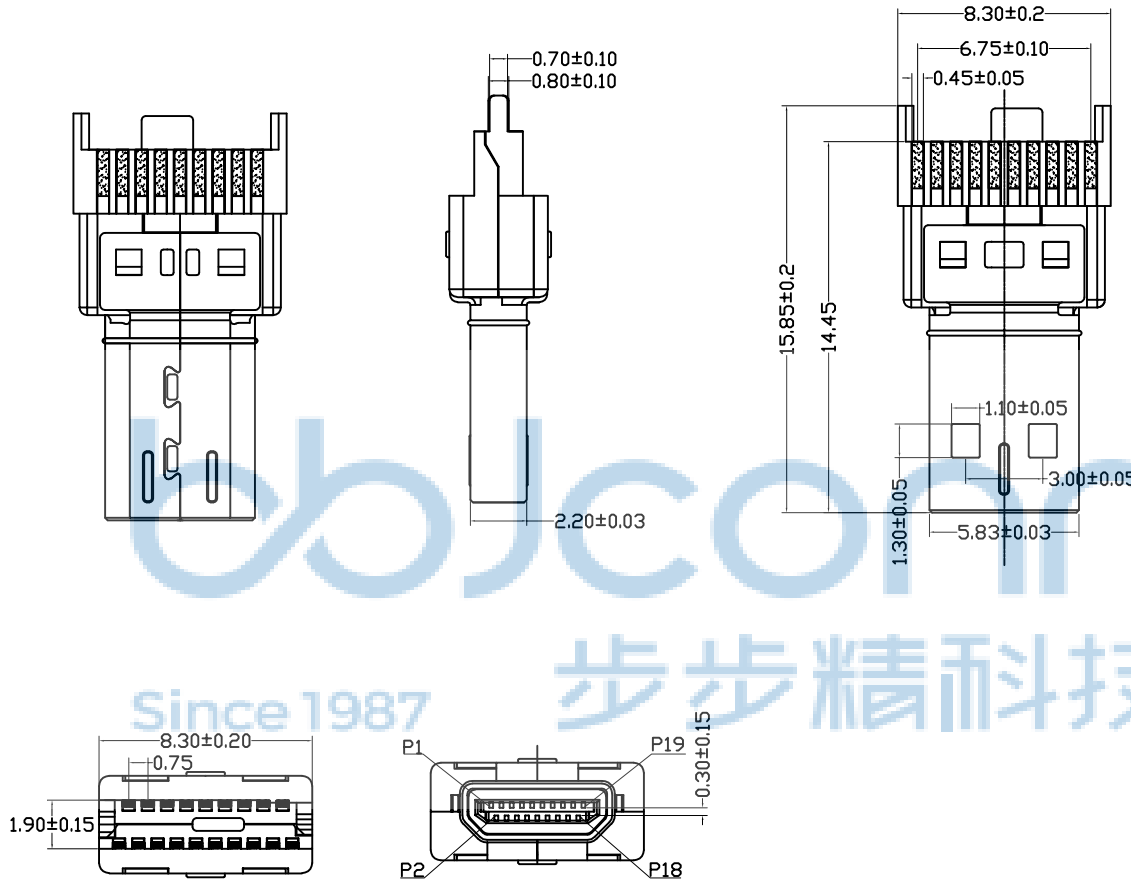

LATCH	PBT	1	BLACK, UL 94V-0
SHELL	SUS304 1/2H C2680/SPCC	1	PLATED OVER 100u" NI min.
9Pin CONTACT	C5191	9	CONTACT AREA: GOLD PLATED OVER 50u" NI min. SOLDED AREA: 100u" MIST TIN PLATED OVER 50u" NI min.
10Pin CONTACT (SHORT)	C5191	10	SOLDED AREA: 100u" MIST TIN PLATED OVER 50u" NI min.
BACK INSERT HOUSING	LCP	2	BLACK, UL 94V-0
HOUSING	LCP	1	BLACK, UL 94V-0
PART NAME	Mechanical	QT' Y	NOTE



THIS DOCUMENT IS THE SOLE PROPERTY OF BBJconn Technology Co.,Ltd. Corporation AND SHOULD NOT BE USED IN WHOLE OR IN PART WITHOUT PRIOR WRITTEN PERMISSION.

PDWG.NO: 0301-1

DR. SGF

NAME: HDMI 19P 公头 180度 H=14.45 LCP黑胶焊线式 不锈钢外壳

PJ. NO.: HD.04.71-34-B001

SIZE: A4 | DRW NO.:

FINISH: SEE NOTES | MAT'L.: SEE NOTES

SCALE: N/A | REV.: AO | UNIT: mm | PAGE: 1/2

深圳市步步精科技有限公司

REV.	ECN NO	CONTENT	DATE	ENGINEER
A0				

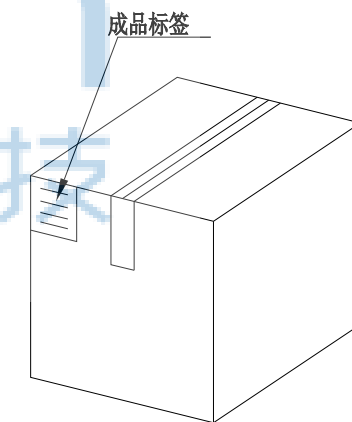
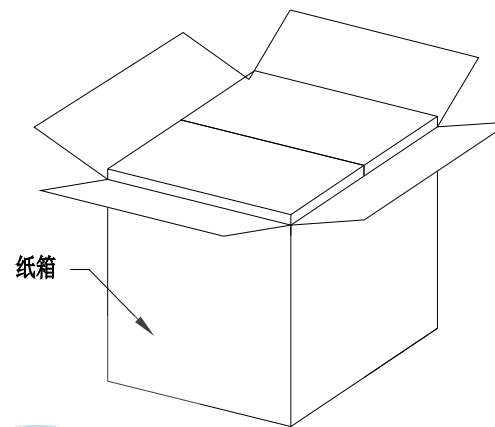
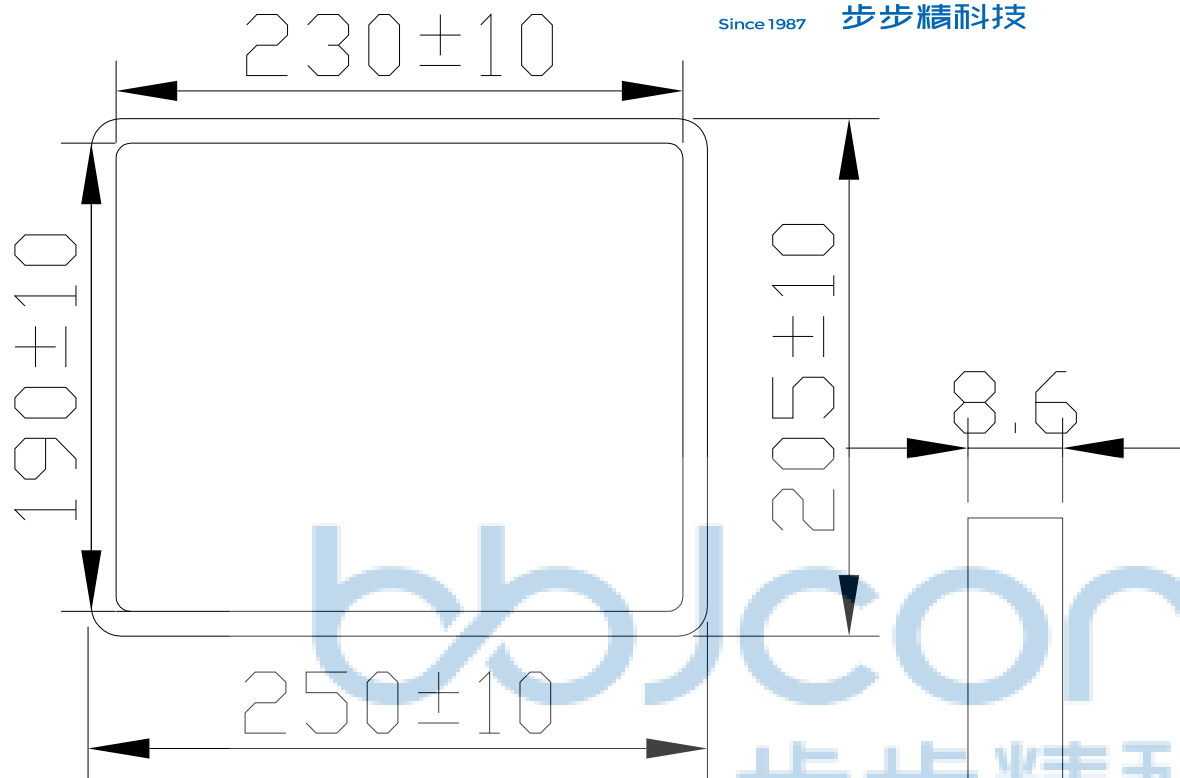

纸箱规格: 350\*210\*290

1. 包装要求:

- 1.1 每盒吸塑盒包装100pcs;
- 1.2 每20盘放一箱, 共计2000PCS;
- 1.3 纸箱外贴上标签



THIS DOCUMENT IS THE SOLE PROPERTY OF BBJconn Technology Co.,Ltd. Corporation AND SHOULD NOT BE USED IN WHOLE OR IN PART WITHOUT PRIOR WRITTEN PERMISSION.		深圳市步步精科技有限公司 .X: ±0.38    X': ±3" .XX: ±0.25    X'': ±2" .XXX: ±0.13    XX': ±1"		NAME: HDMI 19P 公头 180度 H=14.45 LCP黑胶焊线式 不锈钢外壳	
APPD.	JM_Zheng	PJ. NO.: HD.04.71-34-B001		SIZE: A4   DRW NO.:	
CHKD.	LYX	FINISH: SEE NOTES    MAT'L.: SEE NOTES		SCALE: N/A   REV.: A0    UNIT: mm    PAGE: 2/2	
PDWG.NO:	0301-1	DR.	SGF		