

SECTION A-A  
SCALE 1:1



REV.	ECN NO	CONTENT	DATE	ENGINEER
A0				

**Note:**

- Material:
  - Housing: thermoplastic high temp.UL94V-0; Color: natural.
  - Latch: thermoplastic high temp.UL94V-0; Color: black.
  - Terminal: copper alloy.
  - Fitting Nail: copper alloy.
- Finish:
  - Terminal: Underplating: Au/matt Tin overall.
  - Fitting Nail: Underplating: matt Tin overall.
- Product must comply HF RoHS specification.

CKTS	DIM A	DIM B	DIM C	DIM D
4	1.50	2.60	5.50	5.60
5	2.00	3.10	6.00	6.10
6	2.50	3.60	6.50	6.60
7	3.00	4.10	7.00	7.10
8	3.50	4.60	7.50	7.60
9	4.00	5.10	8.00	8.10
10	4.50	5.60	8.50	8.60
11	5.00	6.10	9.00	9.10
12	5.50	6.60	9.50	9.60
13	6.00	7.10	10.00	10.10
14	6.50	7.60	10.50	10.60
15	7.00	8.10	11.00	11.10
16	7.50	8.60	11.50	11.60
17	8.00	9.10	12.00	12.10
18	8.50	9.60	12.50	12.60
19	9.00	10.10	13.00	13.10
20	9.50	10.60	13.50	13.60
21	10.00	11.10	14.00	14.10
22	10.50	11.60	14.50	14.60
23	11.00	12.10	15.00	15.10
24	11.50	12.60	15.50	15.60
25	12.00	13.10	16.00	16.10
26	12.50	13.60	16.50	16.60
27	13.00	14.10	17.00	17.10
28	13.50	14.60	17.50	17.60
29	14.00	15.10	18.00	18.10
30	14.50	15.60	18.50	18.60
31	15.00	16.10	19.00	19.10
32	15.50	16.60	19.50	19.60
33	16.00	17.10	20.00	20.10
34	16.50	17.60	20.50	20.60
35	17.00	18.10	21.00	21.10
36	17.50	18.60	21.50	21.60
37	18.00	19.10	22.00	22.10
38	18.50	19.60	22.50	22.60
39	19.00	20.10	23.00	23.10
40	19.50	20.60	23.50	23.60
41	20.00	21.10	24.00	24.10
42	20.50	21.60	24.50	24.60
43	21.00	22.10	25.00	25.10
44	21.50	22.60	25.50	25.60
45	22.00	23.10	26.00	26.10
46	22.50	23.60	26.50	26.60
47	23.00	24.10	27.00	27.10
48	23.50	24.60	27.50	27.60
49	24.00	25.10	28.00	28.10
50	24.50	25.60	28.50	28.60
51	25.00	26.10	29.00	29.10
52	25.50	26.60	29.50	29.60
53	26.00	27.10	30.00	30.10
54	26.50	27.60	30.50	30.60
55	27.00	28.10	31.00	31.10
56	27.50	28.60	31.50	31.60
57	28.00	29.10	32.00	32.10
58	28.50	29.60	32.50	32.60
59	29.00	30.10	33.00	33.10
60	29.50	30.60	33.50	33.60

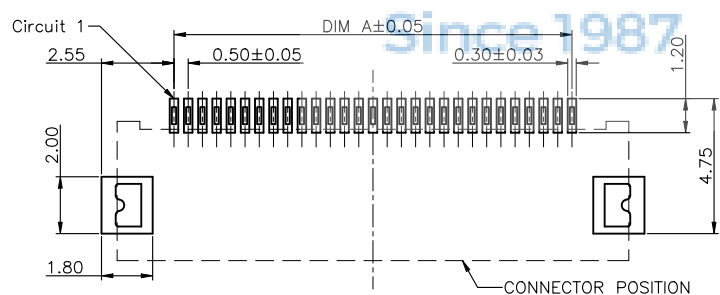
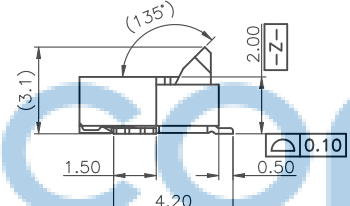
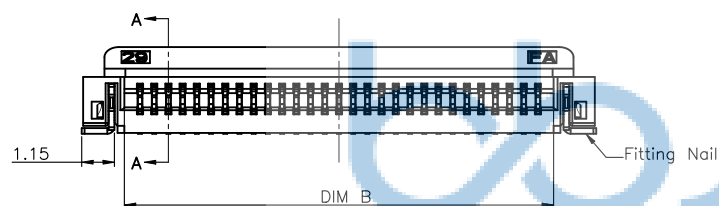

RECOMMENDED P.C.B PATTERN LAYOUT

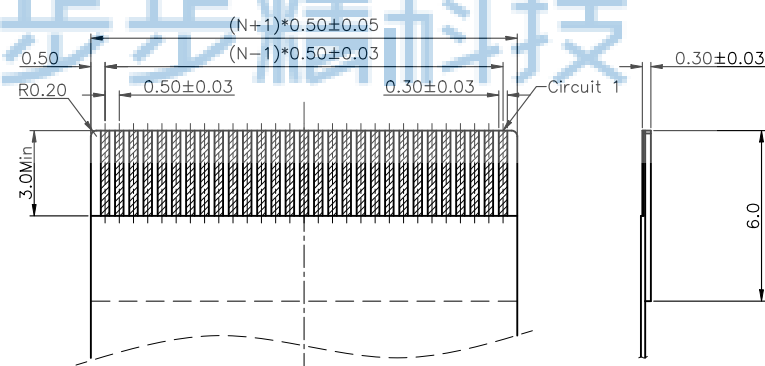

RECOMMENDED FPC/FFC DIMENSION



THIS DOCUMENT IS THE SOLE PROPERTY OF BBJconn Technology Co.,Ltd. Corporation AND SHOULD NOT BE USED IN WHOLE OR IN PART WITHOUT PRIOR WRITTEN PERMISSION.		<b>深圳市步步精科技有限公司</b> NAME: FPC 0.5-12P 后翻式 H=2.0 点镀金G-F (AFC24)	
PDWG,NO: 0167-1	DR. TSP	APPD. JM_Zheng	CHKD. LYX
		PJ. NO.: PC.02.05-32-2001 SIZE: A4 DRW NO.: FINISH: SEE NOTES MAT'L.: SEE NOTES SCALE: N/A REV.: AO UNIT: mm PAGE: 1/2	

REV.	ECN NO	CONTENT	DATE	ENGINEER
AO				

- NOTES:
1. 10 SPROCKET HOLE PITCH CUMULATIVE TOLERANCE.  $\pm 0.20\text{mm}$
  2. CARRIER CAMBER NOT TO EXCEED 1mm IN 250mm.
  3. ALL DIMENSIONS MEET EIA-481-C REQUIREMENTS.
  4. MATERIAL: BLACK ANTI-STATIC POLYSTYRENE.
  5. THICKNESS:  $0.35 \pm 0.05 \text{ mm}$ .
  6. PACKING LENGTH PER 13" REEL : 18.60METERS.
  7. COMPONENT LOAD PER 13" REEL : 1500PCS.
  8. PEELING OFF FORCE OF TOP TAPE  $0.1\text{N} \sim 0.7\text{N} (10.2\text{gf} \sim 71.4\text{gf})$ .

CKTS	B0 $\pm 0.10$	W	W1	F	S0 $\pm 0.10$
4	5.80	16+0.3/-0	16.4	7.5 $\pm 0.10$	
5	6.30				
6	6.80				
7	7.30				
8	7.80				
9	8.30				
10	8.80				
11	9.30	24+0.3/-0	24.4	11.5 $\pm 0.10$	单边孔
12	9.80				
13	10.30				
14	10.80				
15	11.30				
16	11.80				
17	12.30				
18	12.80	32 $\pm 0.30$	32.4	14.2 $\pm 0.10$	28.4
19	13.30				
20	13.80				
21	14.30				
22	14.80				
23	15.30				
24	15.80				
25	16.30	44 $\pm 0.30$	44.4	20.2 $\pm 0.15$	40.4
26	16.80				
27	17.30				
28	17.80				
29	18.30				
30	18.80				
31	19.30				
32	19.80	56 $\pm 0.30$	56.4	26.2 $\pm 0.15$	52.4
33	20.30				
34	20.80				
35	21.30				
36	21.80				
37	22.30				
38	22.80				
39	23.30				
40	23.80				
41	24.30				
42	24.80				
43	25.30				
44	25.80				
45	26.30				
46	26.80				
47	27.30				
48	27.80				
49	28.30				
50	28.80				
51	29.30				
52	29.80				
53	30.30				
54	30.80				
55	31.30				
56	31.80				
57	32.30				
58	32.80				
59	33.30				
60	33.80				

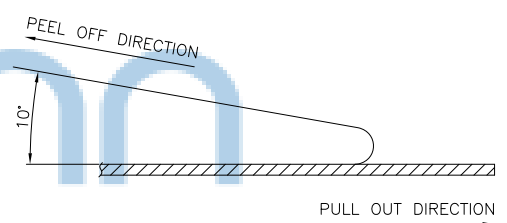
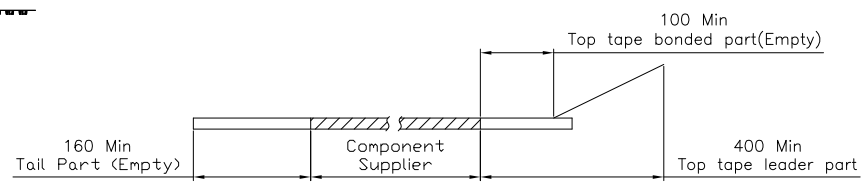
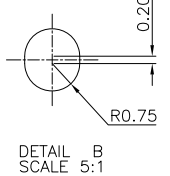
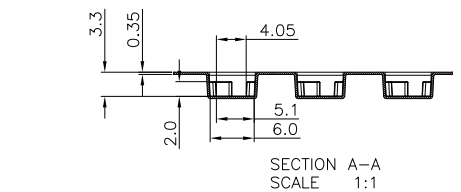
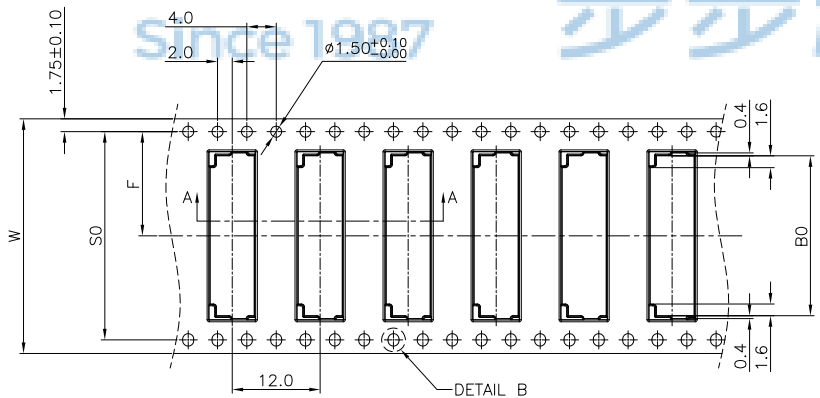
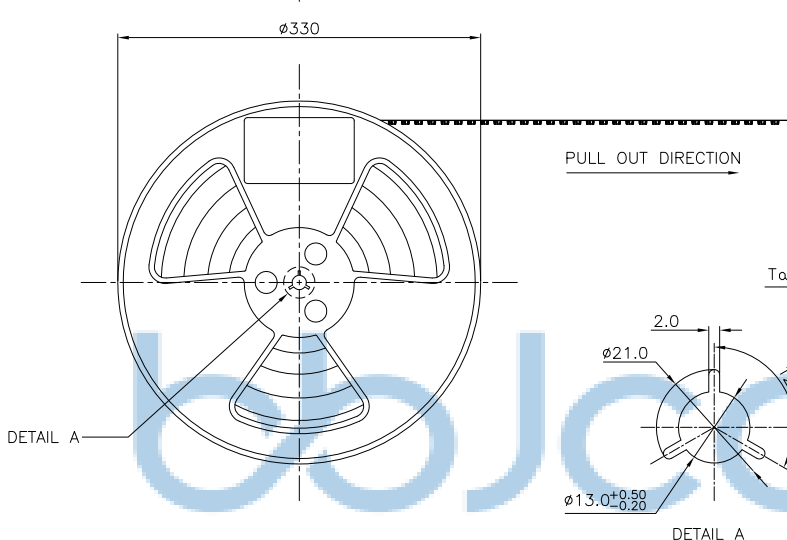
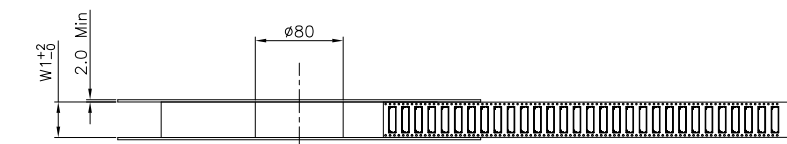

THIS DOCUMENT IS THE SOLE PROPERTY OF BBJconn Technology Co., Ltd. CORPORATION AND SHOULD NOT BE USED IN WHOLE OR IN PART WITHOUT PRIOR WRITTEN PERMISSION.

PDWG.NO: 0167-1

APPD. JM\_Zheng  
CHKD. LYX  
DR. TSP

NAME: FPC 0.5-12P 后翻式 H=2.0 点镀金G-F (AFC24)

PJ. NO.: PC.02.05-32-2001  
SIZE: A4 DRW NO.:

FINISH: SEE NOTES MAT'L.: SEE NOTES  
SCALE: N/A REV.: AO UNIT: mm PAGE: 2/2

**深圳市步步精科技有限公司**