

REV.	ECN NO.	CONTENT	DATE	ENGINEER
AO				

NOTES:

- MATERIAL:  
HOUSING: HIGHT-TEMP PLASTIC,UL 94V-0,COLOR:NATURE/BLACK;  
COVER: HIGHT-TEMP PLASTIC,UL 94V-0,COLOR:BLACK;  
TERMINAL: COPPER ALLOY;  
PEG: COPPER ALLOY;
- PLATING:  
TERMINAL: GOLD PLATED ON NICKEL OVERALL.  
PEG: TIN PLATED ON NICKEL OVERALL.
- RATING:  
CURRENT RATING: 0.3A AC/DC  
VOLTAGE RATING: 30V AC/DC  
TEMPERATURE RANGE: -55°C~+85°C;

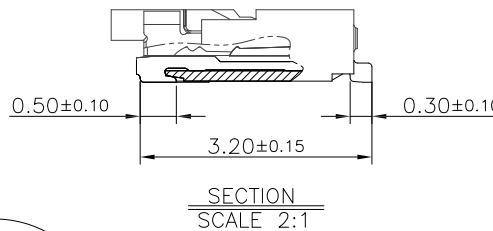
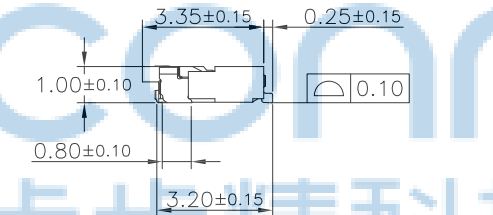
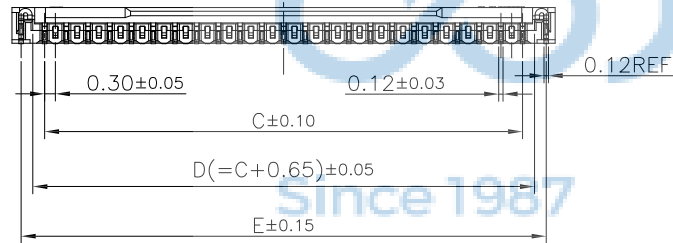
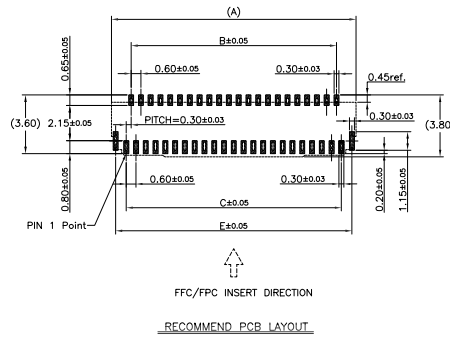
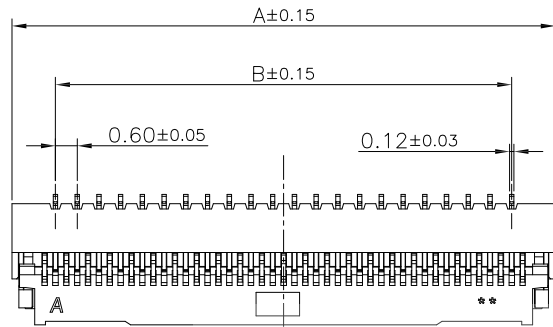

PIN NO.	DIM A	DIM B	DIM C	DIM D	DIM E
13	5.40	3.00	3.60	4.25	4.90
15	6.00	3.60	4.20	4.85	5.50
17	6.60	4.20	4.80	5.45	6.10
19	7.20	4.80	5.40	6.05	6.70
21	7.80	5.40	6.00	6.65	7.30
23	8.40	6.00	6.60	7.25	7.90
25	9.00	6.60	7.20	7.85	8.50
27	9.60	7.20	7.80	8.45	9.10
29	10.20	7.80	8.40	9.05	9.70
31	10.80	8.40	9.00	9.65	10.30
33	11.40	9.00	9.60	10.25	10.90
35	12.00	9.60	10.20	10.85	11.50
37	12.60	10.20	10.80	11.45	12.10
39	13.20	10.80	11.40	12.05	12.70
41	13.80	11.40	12.00	12.65	13.30
43	14.40	12.00	12.60	13.25	13.90
45	15.00	12.60	13.20	13.85	14.50
47	15.60	13.20	13.80	14.45	15.10
49	16.20	13.80	14.40	15.05	15.70
51	16.80	14.40	15.00	15.65	16.30
53	17.40	15.00	15.60	16.25	16.90
55	18.00	15.60	16.20	16.85	17.50
57	18.60	16.20	16.80	17.45	18.10
59	19.20	16.80	17.40	18.05	18.70
61	19.80	17.40	18.00	18.65	19.30
63	20.40	18.00	18.60	19.25	19.90
65	21.00	18.60	19.20	19.85	20.50
67	21.60	19.20	19.80	20.45	21.10
69	22.20	19.80	20.40	21.05	21.70
71	22.80	20.40	21.00	21.65	22.30

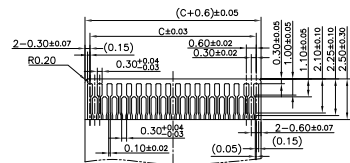

APPLICABLE FFC/FPC  
FFC/FPC THICKNESS=0.20±0.03

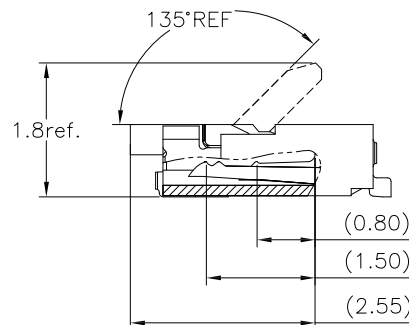

THIS DOCUMENT IS THE SOLE PROPERTY OF BBJconn Technology Co.,Ltd. Corporation AND SHOULD NOT BE USED IN WHOLE OR IN PART WITHOUT PRIOR WRITTEN PERMISSION.

PDWG.NO: 0428-1

DR. SGF

APPD. JM\_Zheng

CHKD. LYX

NAME: FPC 0.3-31P 翻盖下接 H=1.0 编带

PJ. NO.: PC.01.04-12-D002

SIZE: A4 | DRW NO.:

FINISH: SEE NOTES | MAT'L.: SEE NOTES

SCALE: N/A | REV.: AO | UNIT: mm | PAGE: 1/2

深圳市步步精科技有限公司

.X: ±0.38 X': ±3'  
.XX: ±0.25 .X': ±2'  
.XXX: ±0.13 .XX': ±1'

REV.	ECN NO.	CONTENT	DATE	ENGINEER
A0				

NOTES:

1. ALL DIMENSION MEET EIA-481-3 REQUIREMENTS;
2. CARRRIER MATERIAL: PS, BLACK;
3. PACKING QULITY: 5000PCS/REEL;

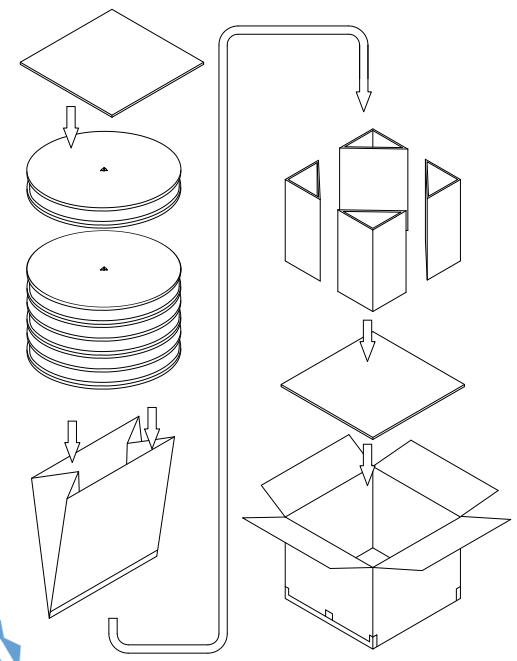
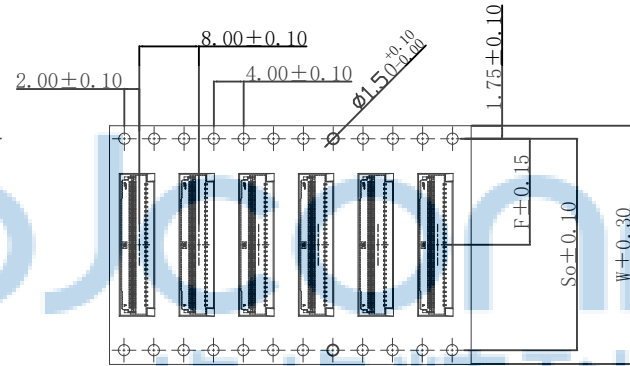
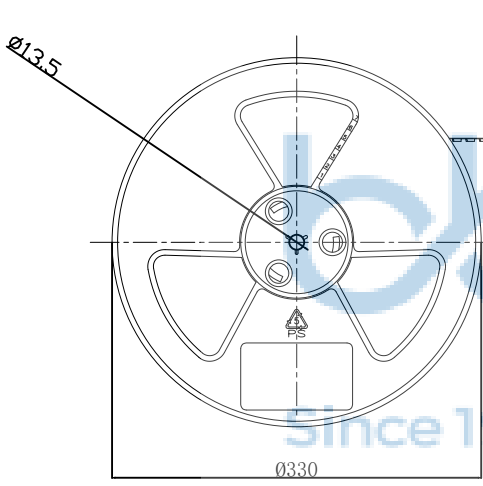
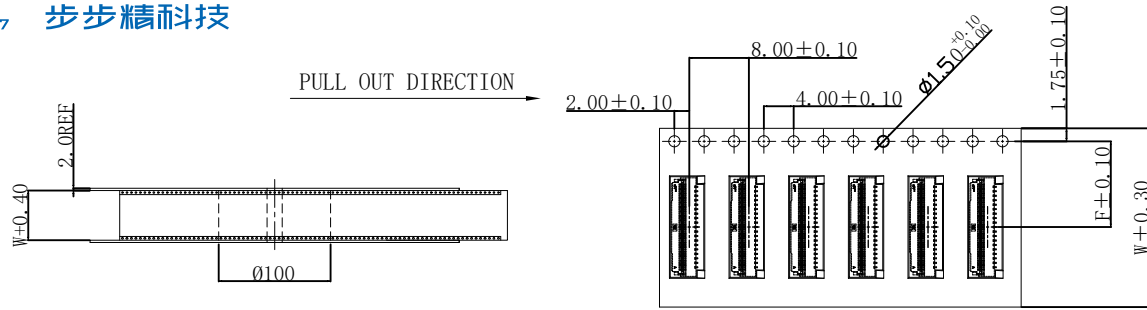

SCALE 3:20

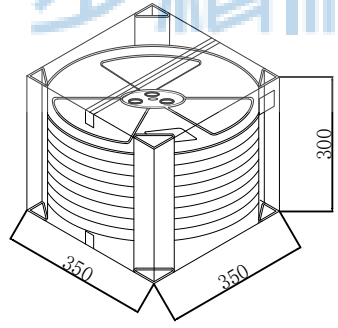

PACKING DISCRPTION:

PIN No.	13~25	27~51	57~67	71
REEL WIDTH	16.4	24.4	32.4	44.4
PCS/REEL	5000	5000	5000	5000
REEL/BOX	12	9	7	6
BOX/PCS	60K	45K	35K	30K
CTN. SIZE	350*350*300			

PIN NO.	DIM W	DIM F	DIM So
13~25	16.0	7.50±0.10	--
27~51	24.0	11.50±0.10	--
57~67	32.0	14.20±0.10	28.4
71	44.0	20.20±0.15	40.4

THIS DOCUMENT IS THE SOLE PROPERTY OF BBJconn Technology Co.,Ltd. Corporation AND SHOULD NOT BE USED IN WHOLE OR IN PART WITHOUT PRIOR WRITTEN PERMISSION.

PDWG.No: 0428-1

DR. SGF

APPD. JM\_Zheng

CHKD. LYX

APPROVED

深圳市步步精科技有限公司

NAME: FPC 0.3-31P 翻盖下接 H=1.0 (FPC0310-31)

P.J. NO.: PC.01.04-12-D002

SIZE: A4 DRW NO.:

FINISH: SEE NOTES MAT'L: SEE NOTES

SCALE: N/A REV: A0 UNIT: mm PAGE: 2/2