

REV.	ECN NO	CONTENT	DATE	ENGINEER
A0				

技术要求:

- 1、塑件材料: LCP (UL-94V-0)
- 2、接触件: 黄铜镀锡
- 3、接触电阻: $\leq 30m\Omega$
- 4、绝缘电阻: $\geq 1000M\Omega$
- 5、额定电压: 250V AC DC
- 6、额定电流: 7.0A AC DC
- 7、耐压: 能承受1000V AC/Minute
- 8、工作温度: $-25^{\circ}\sim\sim+85^{\circ}$
- 9、可焊性试验: 浸锡面积 $\geq 95\%$ 温度260,时间 2.5 ± 0.5 秒
- 10、铅和镉等六大有害物质含量要符合环保要求

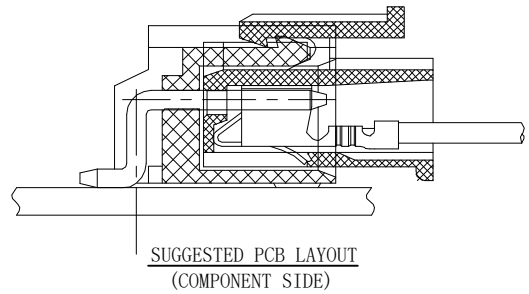
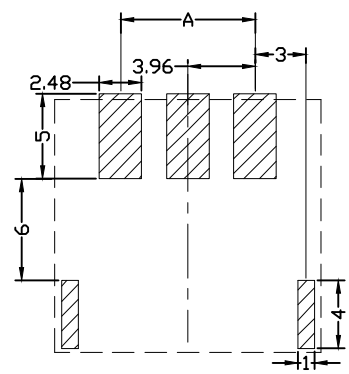
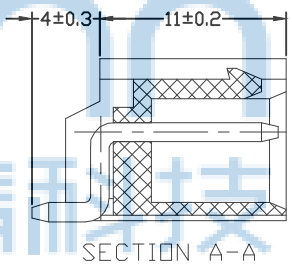
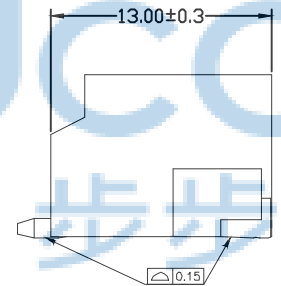
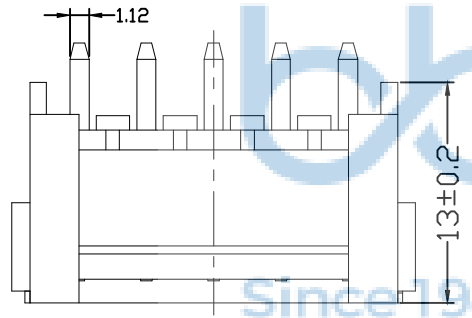
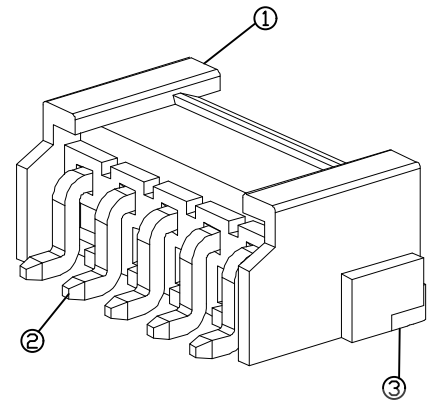
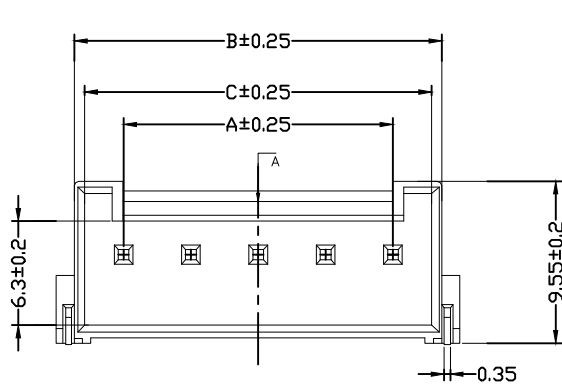

P/n	A	B	C
2	3.96	9.8	8.6
3	7.92	13.76	12.56
4	11.88	17.72	16.52
5	15.84	21.68	20.48
6	19.8	25.64	24.44
7	23.76	29.6	28.4
8	27.72	33.56	32.36
9	31.68	37.52	36.32
10	35.64	45.44	40.28



3	焊片 Fitting Nail	黄铜	2	电蚀蚀: 零件表面蚀蚀30u"MIN, 厚度等 80u"MIN.
2	端子 Contact	黄铜	n*1	电蚀蚀: 零件表面蚀蚀30u"MIN, 厚度等 80u"MIN.
1	基板 Wafer	LCP (UL94V-0)	1	烧蚀
序号	名称	材料	数量	附注

THIS DOCUMENT IS THE SOLE PROPERTY OF BBJconn Technology Co., Ltd. Corporation AND SHOULD NOT BE USED IN WHOLE OR IN PART WITHOUT PRIOR WRITTEN PERMISSION.

PDWG.NO: 0510-1

深圳市步步精科技有限公司

NAME: 针座 VH-2P (3.96-2P) 卧贴 带扣 米黄色

PJ. NO.: WT.03.61-75-M001

SIZE: A4 DRW NO.:

FINISH: SEE NOTES MAT'L.: SEE NOTES

SCALE: N/A REV.: A0 UNIT: mm PAGE: 1/2

APPD. JM_Zheng

CHKD. LYX

DR. SGF

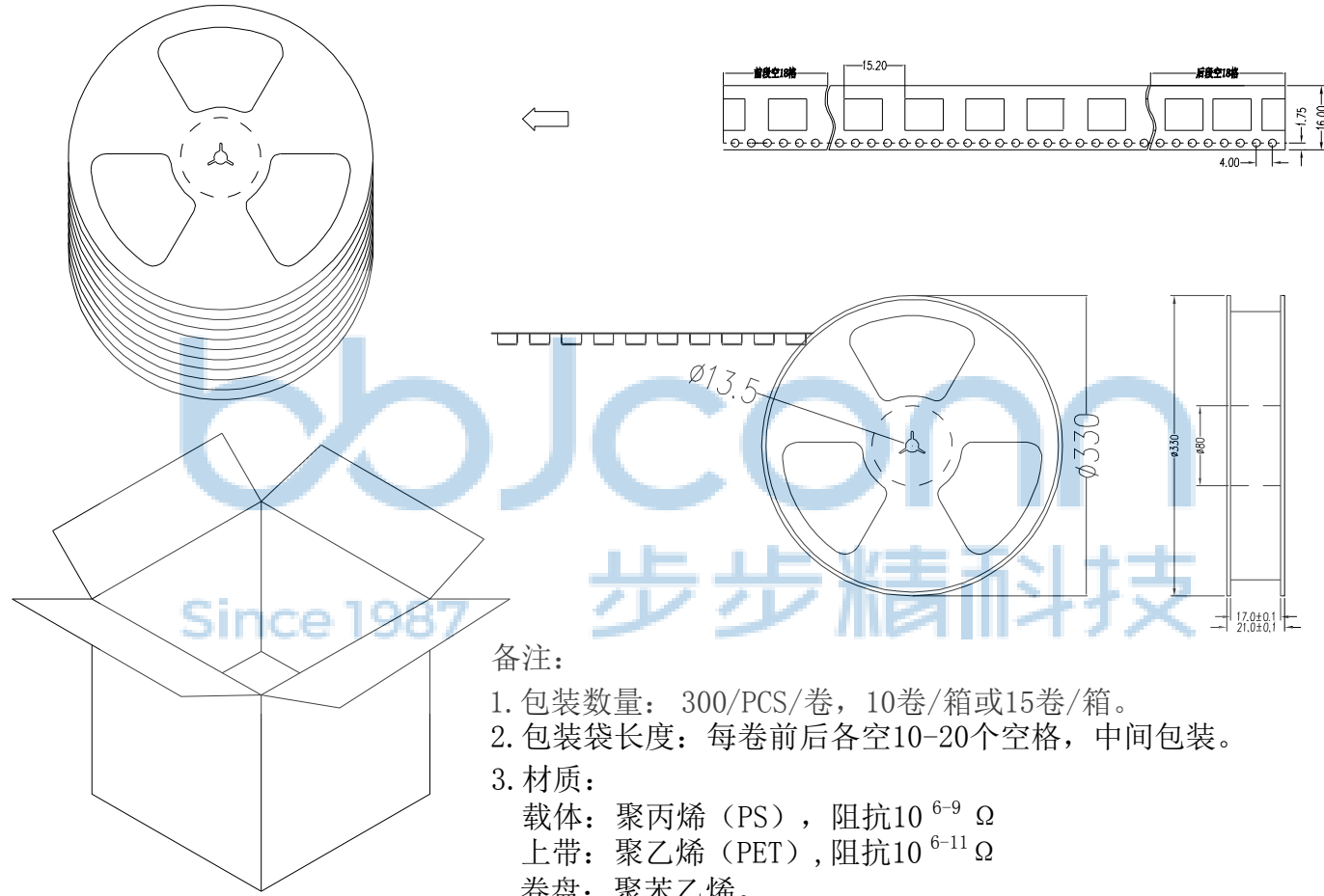

备注:

1. 包装数量: 300/PCS/卷, 10卷/箱或15卷/箱。
2. 包装袋长度: 每卷前后各空10-20个空格, 中间包装。
3. 材质:
 载体: 聚丙烯 (PS), 阻抗 $10^{6-9} \Omega$
 上带: 聚乙烯 (PET), 阻抗 $10^{6-11} \Omega$
 卷盘: 聚苯乙烯。

纸箱规格: 345*345*23MM
 纸箱规格: 345*345*35MM

THIS DOCUMENT IS THE SOLE PROPERTY OF BBJconn Technology Co.,Ltd. Corporation AND SHOULD NOT BE USED IN WHOLE OR IN PART WITHOUT PRIOR WRITTEN PERMISSION.		 深圳市步步精科技有限公司	
.X: ±0.38 .XX: ±0.25 .XXX: ±0.13		X': ±3" .X": ±2" .XX': ±1"	
APPD.	JM_Zheng	NAME: 针座 VH-2P (3.96-2P) 卧贴 带扣 米黄色	
CHKD.	LYX	PJ. NO.: WT.03.61-75-M001	
DR.	SGF	SIZE: A4 DRW NO.:	
PDWG.NO: 0510-1		FINISH: SEE NOTES MAT'L.: SEE NOTES	
		SCALE: N/A REV.: A0 UNIT: mm PAGE: 2/2	