

REV.	ECN NO	CONTENT	DATE	ENGINEER
A0				

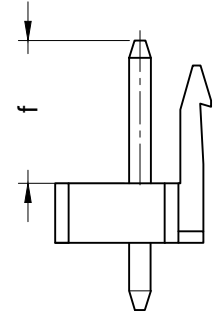

°_?±"r Ö
 Ä•&€ÉÖ3\$ Ä8/ 9 Ä
 Ä Ö@ & ÖTök KpKQ
 Ä Ö@ +eLk Ö 0 P i
 Ä5 5H+eLk Ö 1 0 i
 ÄNí Ê+e » Ö 9 \$& ' &
 ÄNí Ê+e#q Ö \$ \$& ' &
 Ä6@ » Ö7- 9 \$& @leQ
 Ä œ\$Y Ö Ö e a a e
 Ä ': WB P¼ Ö#KQM'0 1 \$Y Ö .0^e &L\$
 f 0
 ÄJö ¼Ky1y • W 9 ä(TM CX [Gy?±1V 8)ß ?±"r

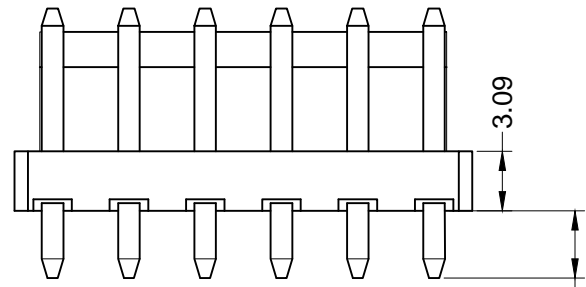
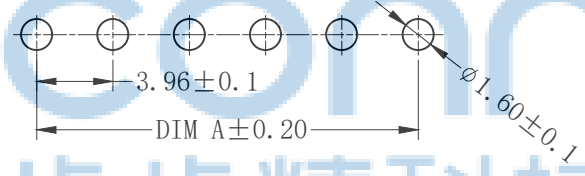
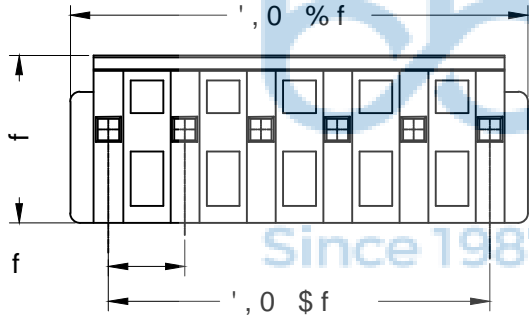

SUGGESTED PCB LAYOUT
(COMPONENT SIDE)

Circuits	Dimensions(mm)	
	A	B
02	3.96	7.92
03	7.92	11.88
04	11.88	15.84
05	15.84	19.80
06	19.80	23.76
07	23.76	27.72
08	27.72	31.68
09	31.68	35.64
10	35.64	39.60
11	39.60	43.56
12	43.56	47.52
13	47.52	51.48
...
20	75.24	79.20

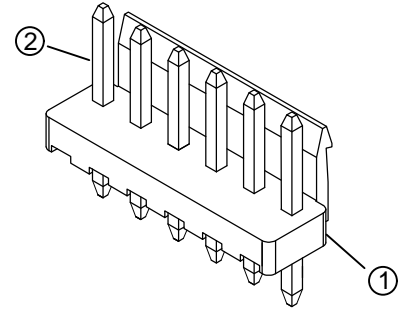

2	端子 Contact	黄铜	n×1	电镀(铜): 整个表面镀厚度30u"MIN, 厚镀铜 80u"MIN.
1	基板 Wafer	PA66 (UL94V-0)	1	米黄色
¿' = 0	€ É	Gy	Lt #	

THIS DOCUMENT IS THE SOLE PROPERTY OF BBJconn Technology Co.,Ltd. Corporation AND SHOULD NOT BE USED IN WHOLE OR IN PART WITHOUT PRIOR WRITTEN PERMISSION.

PDWG.NO: 0510-1

APPD. JM_Zheng
CHKD. LYX
DR. SGF

NAME: Öëxù VH-4A(3.96-4P) Ö±Öë Äx»ÆÉ«

PJ. NO.: WT.03.61-11-M001
SIZE: A4 DRW NO.:
FINISH: SEE NOTES MAT'L.: SEE NOTES
SCALE: N/A REV.: A0 UNIT: mm PAGE: 1/2

REV.	ECN NO	CONTENT	DATE	ENGINEER
A0				

PE袋规格:***X*** (以实际出货为准)

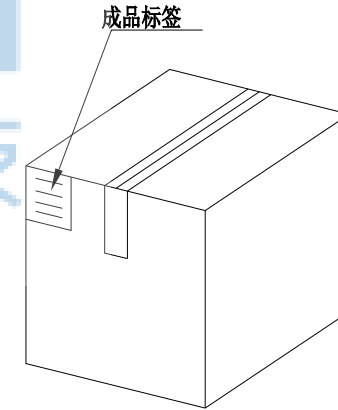
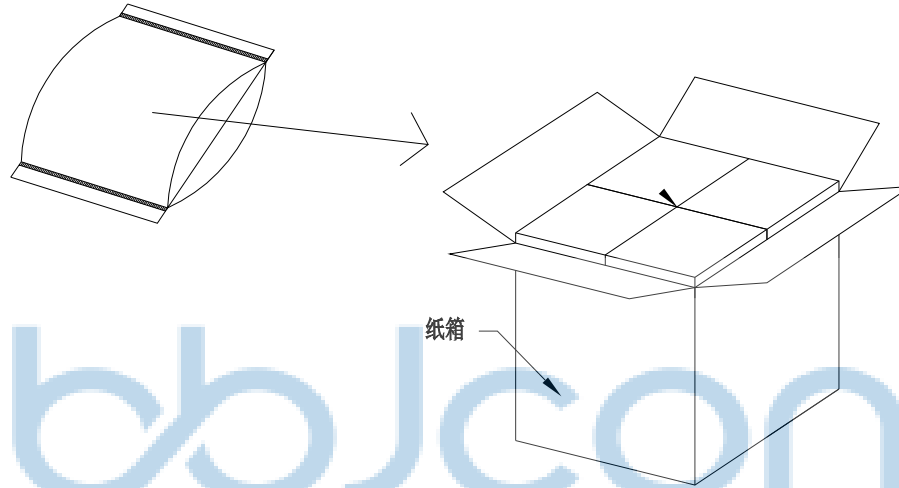

1. 包装要求:

- 1.1 每PE袋包装 1000 pcs;
- 1.2 每1袋放一小纸盒;
- 1.3 每20个小纸盒放一个纸箱, 共计20000PCS
- 1.4 纸箱外贴上标签



THIS DOCUMENT IS THE SOLE PROPERTY OF BBJconn Technology Co., Ltd. Corporation AND SHOULD NOT BE USED IN WHOLE OR IN PART WITHOUT PRIOR WRITTEN PERMISSION.		深圳市步步精科技有限公司 .X: ±0.38 X': ±3' .XX: ±0.25 .X': ±2' .XXX: ±0.13 .XX': ±1'		NAME: 针座 VH-4A(3.96-4P) 直针 米黄色 PJ. NO.: WT.03.61-11-M001 SIZE: A4 DRW NO.: FINISH: SEE NOTES MAT'L.: SEE NOTES SCALE: N/A REV.: A0 UNIT: mm PAGE: 2/2	
APPD.	JM_Zheng	DR.		SGF	
CHKD.	LYX	PDWG.NO:		0510-1	