

使用温度范围 (Ambient temperature Range): $-25^{\circ} \sim +85^{\circ}$
 适用线规 (Applicable Wires): AWG 28#~22#
 适用基板厚度 (Applicable PCboard thickness): 0.8mm~1.6mm
 额定电压 (Voltage rating): 250V AC, DC
 额定电流 (Current rating): 2A
 接触电阻 (Contact Resistance): $\leq 0.01 \Omega$
 绝缘电阻 (Insulation Resistance): $\geq 1000M \Omega$
 耐压 (Withstand Voltage): 800V/min

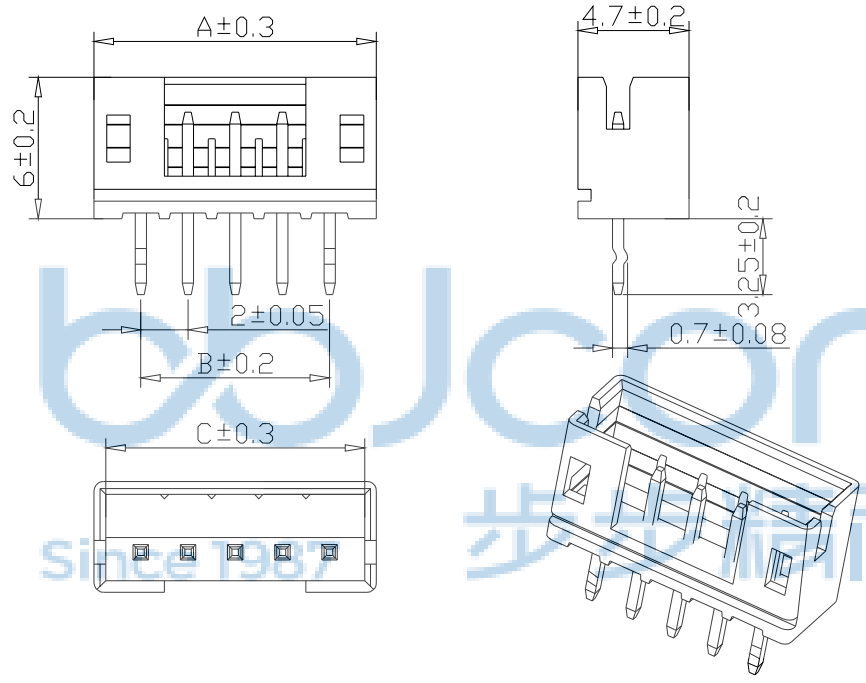

材料 (Material)
 1. 基座: PA66 FV2
 2. 插针: 黄铜

PH直针	A-mm	B-mm	C-mm
2P	6.0mm	2.0mm	5.0mm
3P	8.0mm	4.0mm	7.0mm
4P	10.0mm	6.0mm	9.0mm
5P	12.0mm	8.0mm	11.0mm
6P	14.0mm	10.0mm	13.0mm
7P	16.0mm	12.0mm	15.0mm
8P	18.0mm	14.0mm	17.0mm
9P	20.0mm	16.0mm	19.0mm
10P	22.0mm	18.0mm	21.0mm
11P	24.0mm	20.0mm	23.0mm
12P	26.0mm	22.0mm	25.0mm
13P	28.0mm	24.0mm	27.0mm
14P	30.0mm	26.0mm	29.0mm
15P	32.0mm	28.0mm	31.0mm
16P	34.0mm	30.0mm	33.0mm



范围	>0-3	>3-18	>18-50	>50-100
公差	±0.15	±0.2	±0.3	±0.5
材料	PA66 94V- 2 (0) or ul			

THIS DOCUMENT IS THE SOLE PROPERTY OF BBJconn Technology Co.,Ltd. Corporation AND SHOULD NOT BE USED IN WHOLE OR IN PART WITHOUT PRIOR WRITTEN PERMISSION.

PDWG.NO: 0102-1

DR. SGF

APPD. JM_Zheng

CHKD. LYX

深圳市步步精科技有限公司

NAME: PH-4A (2.0-4P) 直针 打脚 米黄色

PJ. NO.: WT.01.61-31-1001

SIZE: A4 DRW NO.:

FINISH: SEE NOTES MAT'L.: SEE NOTES

SCALE: N/A REV.: A0 UNIT: mm PAGE: 1/2

REV.	ECN NO	CONTENT	DATE	ENGINEER
A0				

PE袋规格:***X*** (以实际出货为准)

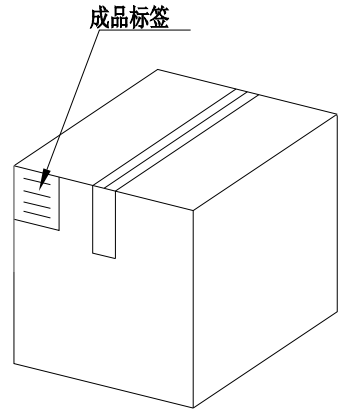
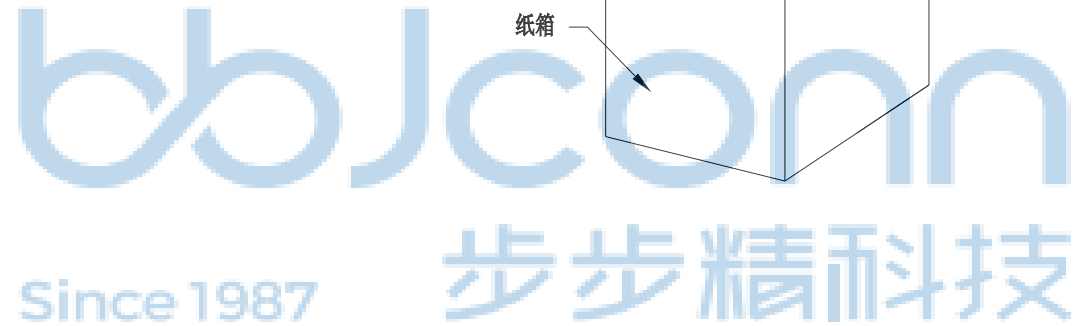
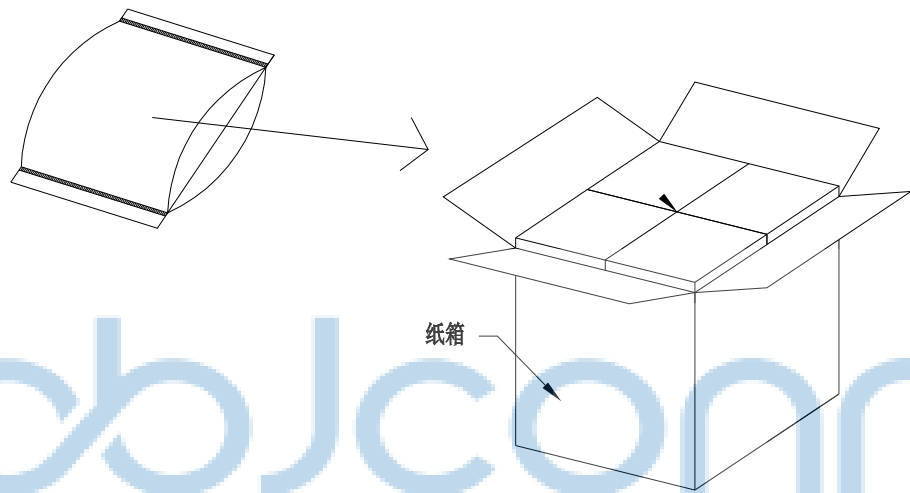

1. 包装要求:
- 1.1 每PE袋包装 2000 pcs;
 - 1.2 每1袋放一小纸盒;
 - 1.3 每20个小纸盒放一个纸箱, 共计40000PCS
 - 1.4 纸箱外贴上标签



THIS DOCUMENT IS THE SOLE PROPERTY OF BBJconn Technology Co.,Ltd. Corporation AND SHOULD NOT BE USED IN WHOLE OR IN PART WITHOUT PRIOR WRITTEN PERMISSION.		深圳市步步精科技有限公司 .X: ±0.38 X': ±3' NAME: .XX: ±0.25 .X': ±2' PH-4A (2.0-4P) 直针 打K脚 米黄色 .XXX: ±0.13 .XX': ±1'	
APPD.	JM_Zheng	PJ. NO.: WT.01.61-31-1001 SIZE: A4 DRW NO.:	
CHKD.	LYX		
PDWG.NO:	0102-1	DR.	SGF
		FINISH: SEE NOTES	MAT'L.: SEE NOTES
		SCALE: N/A	REV.: A0 UNIT: mm PAGE: 2/2