

REV.	ECN NO	CONTENT	DATE	ENGINEER
A0				

使用温度范围 (Ambient temperature Range): $-25^{\circ} \sim +85^{\circ}$
 适用线规 (Applicable Wires): AWG 28#~22#
 适用基板厚度 (Applicable PCboard thickness): 1.6mm
 额定电压 (Voltage rating): 250V AC, DC
 额定电流 (Current rating): 3A
 接触电阻 (Contact Resistance): $\leq 0.02 \Omega$
 绝缘电阻 (Insulation Resistance): $\geq 1000M \Omega$
 耐压 (Withstand Voltage): 800V/min
 材料 (Material)
 1. 基座: PA66 94V-2

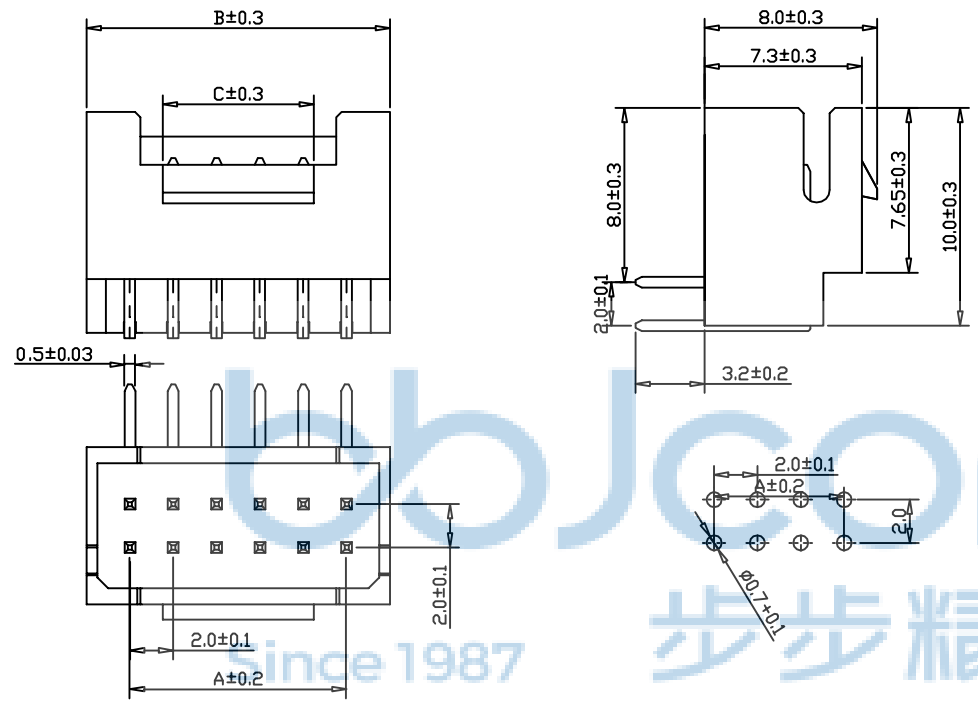

孔位	尺寸 (mm)		
	A	B	C
2x2	2.00	6.00	3.00
2x3	4.00	8.00	3.00
2x4	6.00	10.00	3.00
2x5	8.00	12.00	5.00
2x6	10.00	14.00	7.00
2x7	12.00	16.00	9.00
2x8	14.00	18.00	11.00
2x9	16.00	20.00	13.00
2x10	18.00	22.00	15.00
2x11	20.00	24.00	17.00
2x12	22.00	26.00	19.00
2x13	24.00	28.00	21.00
2x14	26.00	30.00	23.00
2x15	28.00	32.00	25.00



THIS DOCUMENT IS THE SOLE PROPERTY OF BBJconn Technology Co., Ltd. Corporation AND SHOULD NOT BE USED IN WHOLE OR IN PART WITHOUT PRIOR WRITTEN PERMISSION.		深圳市步步精科技有限公司 NAME: PHB-2x3AW (2.0-2x3P) 双排弯针 带扣 米黄色	
APPD.	JM_Zheng	PJ. NO.: WT.15.63-21-1003 SIZE: A4 DRW NO.:	FINISH: SEE NOTES MAT'L.: SEE NOTES SCALE: N/A REV.: A0 UNIT: mm PAGE: 1/2
CHKD.	LYX		
PDWG. NO:	0102-1	DR.	SGF

REV.	ECN NO	CONTENT	DATE	ENGINEER
A0				

PE袋规格:***X*** (以实际出货为准)

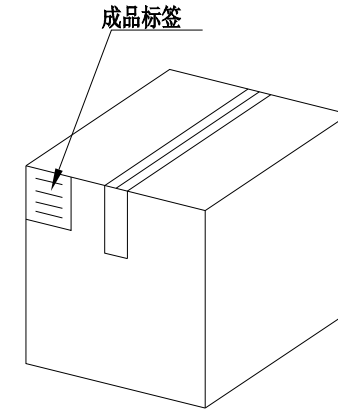
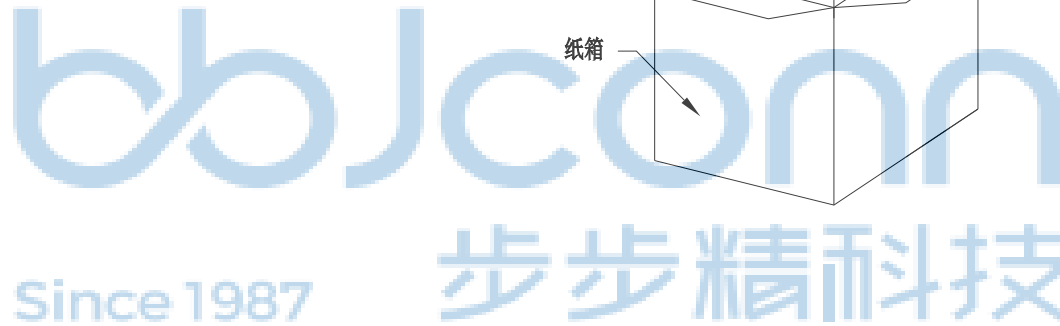
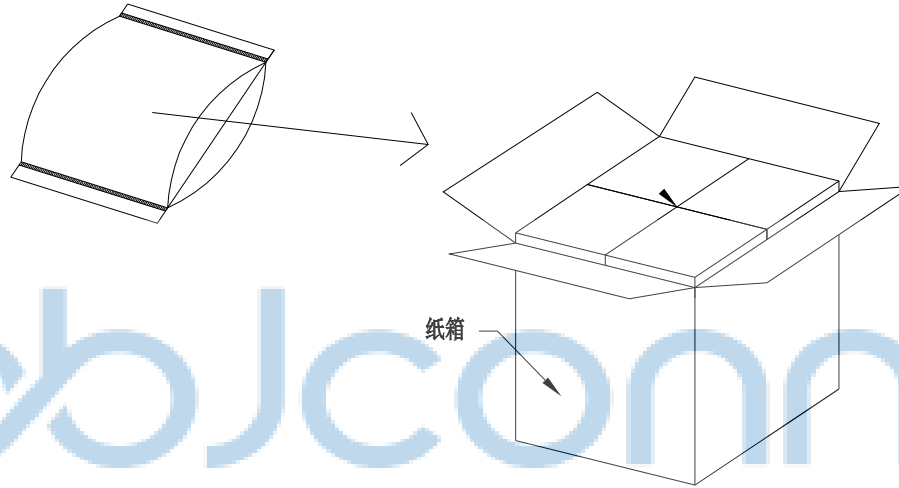

1. 包装要求:
 - 1.1 每PE袋包装 1000PCS;
 - 1.2 每1袋放一小纸盒;
 - 1.3 每20个小纸盒放一个纸箱, 共计20000PCS
 - 1.4 纸箱外贴上标签



THIS DOCUMENT IS THE SOLE PROPERTY OF BBJconn Technology Co.,Ltd. Corporation AND SHOULD NOT BE USED IN WHOLE OR IN PART WITHOUT PRIOR WRITTEN PERMISSION.		深圳市步步精科技有限公司 .X: ±0.38 X': ±3" .XX: ±0.25 .X": ±2" .XXX: ±0.13 .XX": ±1"		NAME: PHB-2x3AW (2.0-2x3P) 双排弯针 带扣 米黄色 PJ. NO.: WT.15.63-21-1003 SIZE: A4 DRW NO.: FINISH: SEE NOTES MAT'L.: SEE NOTES SCALE: N/A REV.: A0 UNIT: mm PAGE: 2/2	
APPD.	JM_Zheng	CHKD.	LYX	DR.	SGF
PDWG.NO: 0102-1					