

REV.	ECN NO	CONTENT	DATE	ENGINEER
A0				

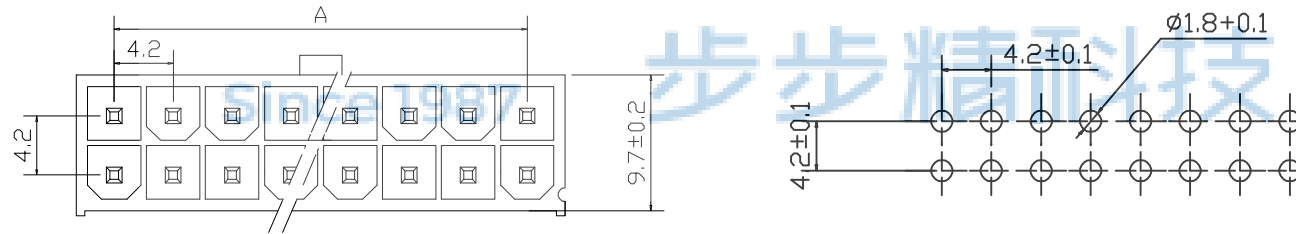

使用温度范围 (Ambient temperature Range):-25° ~+85°  
 适用线规 (Applicable Wires):AWG 28#~20#  
 适用基板厚度 (Applicable PCboard thickness):1.7mm  
 额定电压 (Voltage rating):300V AC,DC  
 额定电流 (Current rating):5A  
 接触电阻 (Contact Resistance): ≤0.015Ω  
 绝缘电阻 (Insulation Resistance): ≥1000MΩ  
 耐压 (Withstand Voltage):1000V/min  
 材料 (Material)  
 1. 基座: PA66 FV2  
 2. 插针: 黄铜

孔位	A	B
2	0	5.4
4	4.2	9.6
6	8.4	13.8
8	12.6	18.0
10	16.8	22.2
12	21.0	26.4
14	25.2	30.6
16	29.4	34.8
18	33.6	39.0
20	37.8	43.2
22	42.0	47.4
24	46.2	51.6

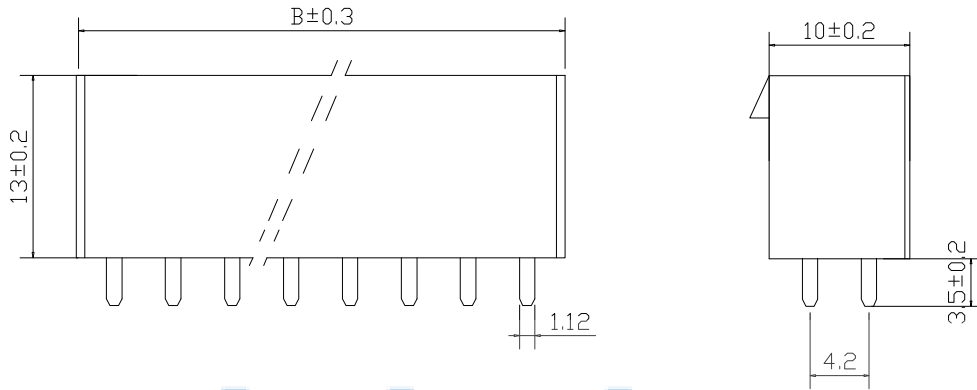

THIS DOCUMENT IS THE SOLE PROPERTY OF BBJconn Technology Co.,Ltd. Corporation AND SHOULD NOT BE USED IN WHOLE OR IN PART WITHOUT PRIOR WRITTEN PERMISSION.		深圳市步步精科技有限公司 NAME: 5569-8A (4.2-2x4P) 双排直针 带扣 透明色	
APPD.	JM_Zheng	PJ. NO.: WT.11.11-11-1002 SIZE: A4 DRW NO.:	FINISH: SEE NOTES MAT'L.: SEE NOTES SCALE: N/A REV.: A0 UNIT: mm PAGE: 1/2
CHKD.	LYX		
PDWG.NO:	0102-1	DR.	SGF

REV.	ECN NO.	CONTENT	DATE	ENGINEER
A0				

PE袋规格:\*\*\*X\*\*\* (0.05μm±0.05) 0.1x1/4

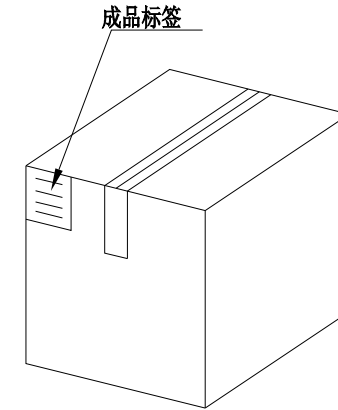
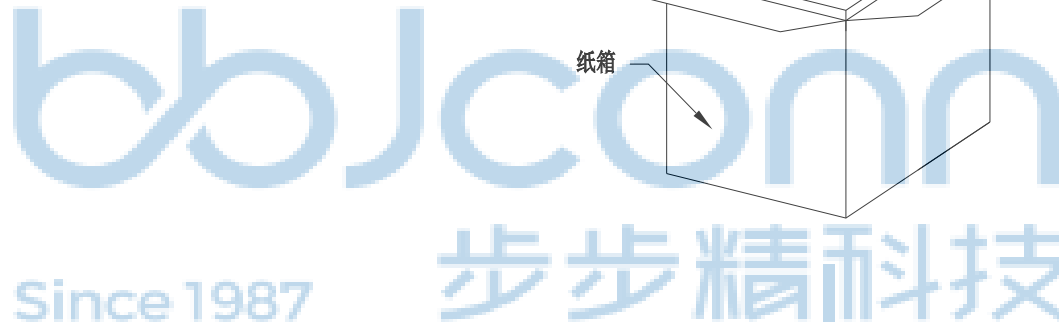
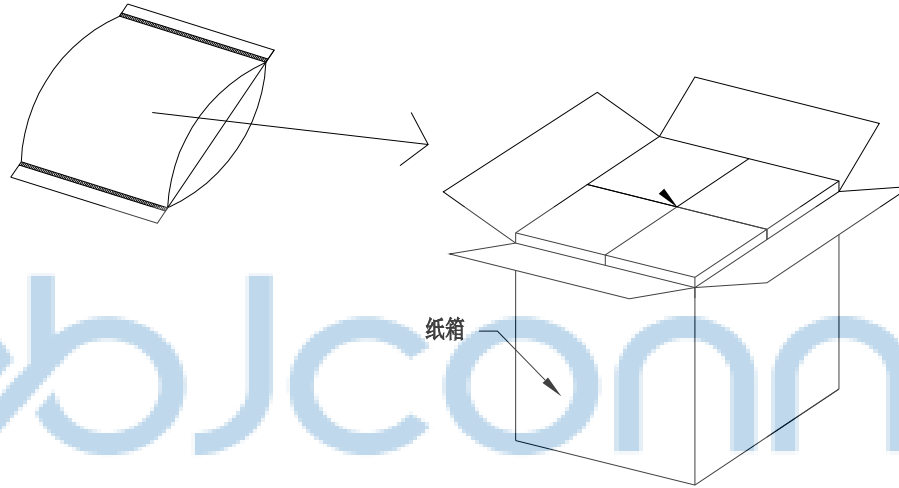

1. 包装要求:

- 1.1 每PE袋包装 500 pcs;
- 1.2 每1袋放一小纸盒;
- 1.3 每20个小纸盒放一个纸箱, 共计10000PCS
- 1.4 纸箱外贴上标签



THIS DOCUMENT IS THE SOLE PROPERTY OF BBJconn Technology Co.,Ltd. Corporation AND SHOULD NOT BE USED IN WHOLE OR IN PART WITHOUT PRIOR WRITTEN PERMISSION.		深圳市步步精科技有限公司 .X: ±0.38    X': ±3' .XX: ±0.25    .X": ±2" .XXX: ±0.13    .XX': ±1'		NAME: 5569-8A£"4.2-2x4P) È«ÅÄÖ±Öë 'ø¿ÛÍ,Ã÷É«	
APPD.	JM_Zheng	PJ. NO.: WT.11.11-11-1002 SIZE: A4   DRW NO.:		FINISH: SEE NOTES    MAT'L.: SEE NOTES	
CHKD.	LYX	SCALE: N/A    REV.: A0    UNIT: mm    PAGE: 2/2		DR.    SGF	
PDWG.NO: 0102-1					