

REV.	ECN NO.	CONTENT	DATE	ENGINEER
A0				

使用温度范围 (Ambient temperature Range):  $-25^{\circ} \sim +85^{\circ}$   
 适用基板厚度 (Applicable PCboard thickness): 0.8mm~1.6mm  
 额定电压 (Voltage rating): 50V AC, DC  
 额定电流 (Current rating): 1A  
 接触电阻 (Contact Resistance):  $\leq 0.01 \Omega$   
 绝缘电阻 (Insulation Resistance):  $\geq 500M \Omega$   
 耐压 (Withstand Voltage): 500V/min  
 材料 (Material)  
 1. 基座: LCP 94V-0 or u1  
 2. 插针: 黄铜

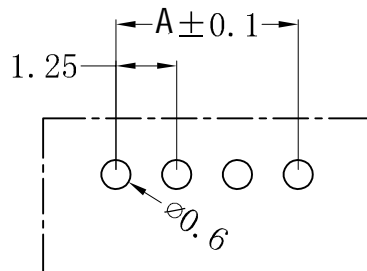

1.25弯针	A-mm	B-mm
1.25-2P	1.25mm	4.50mm
1.25-3P	2.50mm	5.75mm
1.25-4P	3.75mm	7.00mm
1.25-5P	5.00mm	8.25mm
1.25-6P	6.25mm	9.50mm
1.25-7P	7.50mm	10.75mm
1.25-8P	8.75mm	12.00mm
1.25-9P	10.00mm	13.25mm
1.25-10P	11.25mm	14.50mm
1.25-11P	12.50mm	15.75mm
1.25-12P	13.75mm	17.00mm
1.25-13P	15.00mm	18.25mm
1.25-14P	16.25mm	19.50mm
1.25-15P	17.50mm	20.75mm
1.25-16P	18.75mm	22.00mm

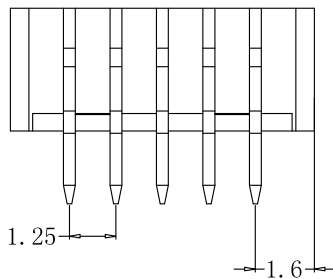
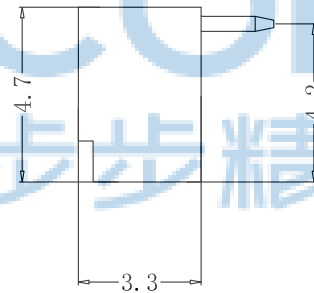
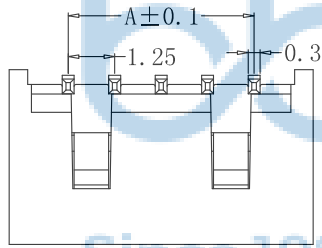
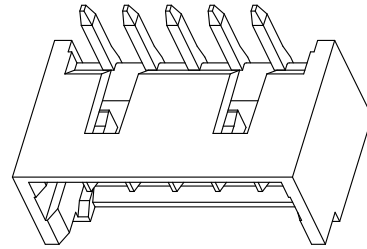
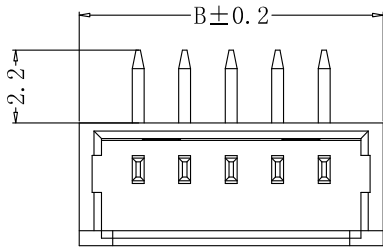

THIS DOCUMENT IS THE SOLE PROPERTY OF BBJconn Technology Co., Ltd. Corporation AND SHOULD NOT BE USED IN WHOLE OR IN PART WITHOUT PRIOR WRITTEN PERMISSION.		<b>深圳市步步精科技有限公司</b> NAME: 1.25-6AW 闭口弯针 米黄色	
APPD.	JM_Zheng	PJ. NO.: WT.04.65-21-1002	
CHKD.	LYX	SIZE: A4 DRW NO.:	
PDWG.NO:	0102-1	DR.	SGF
		FINISH: SEE NOTES MAT'L.: SEE NOTES SCALE: N/A REV.: A0 UNIT: mm PAGE: 1/2	

REV.	ECN NO.	CONTENT	DATE	ENGINEER
A0				

PE袋规格:\*\*\*X\*\*\* (以实际出货为准)

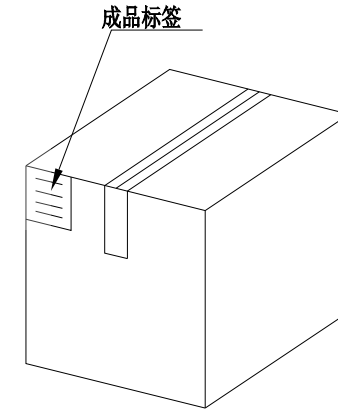
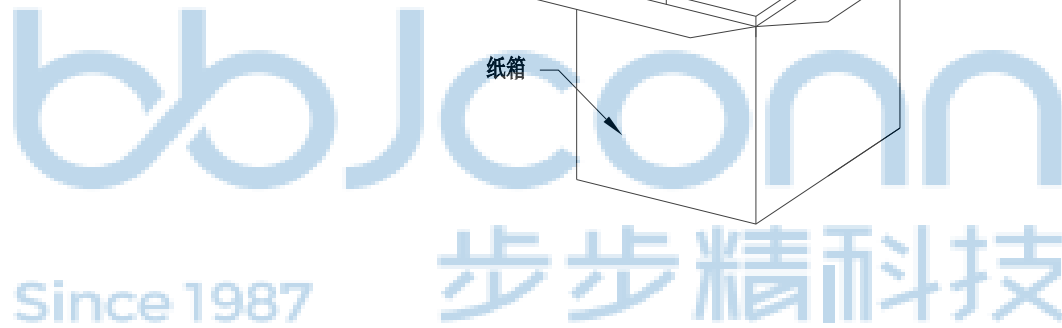
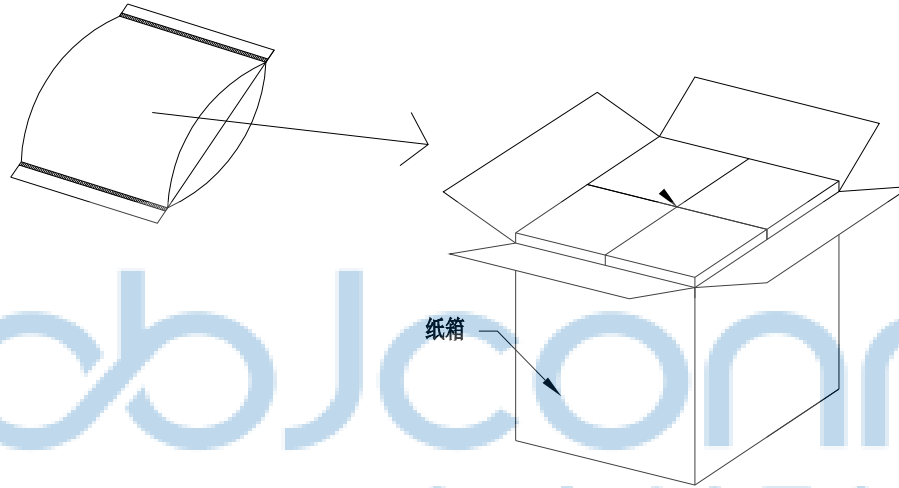

1. 包装要求:

- 1.1 每PE袋包装 2000PCS;
- 1.2 每1袋放一小纸盒;
- 1.3 每20个小纸盒放一个纸箱, 共计40000PCS
- 1.4 纸箱外贴上标签



THIS DOCUMENT IS THE SOLE PROPERTY OF BBJconn Technology Co.,Ltd. Corporation AND SHOULD NOT BE USED IN WHOLE OR IN PART WITHOUT PRIOR WRITTEN PERMISSION.		深圳市步步精科技有限公司 .X: ±0.38    X': ±3" .XX: ±0.25    .X": ±2" .XXX: ±0.13    .XX": ±1"	
APPD.	JM_Zheng	NAME: 1.25-6AW 闭口弯针 米黄色	
CHKD.	LYX	PJ. NO.: WT.04.65-21-1002	
PDWG.NO:	0102-1	SIZE: A4 DRW NO.:	
DR.	SGF	FINISH: SEE NOTES    MAT'L.: SEE NOTES	
		SCALE: N/A    REV.: A0    UNIT: mm    PAGE: 2/2	