

REV.	ECN NO.	CONTENT	DATE	ENGINEER
A0				

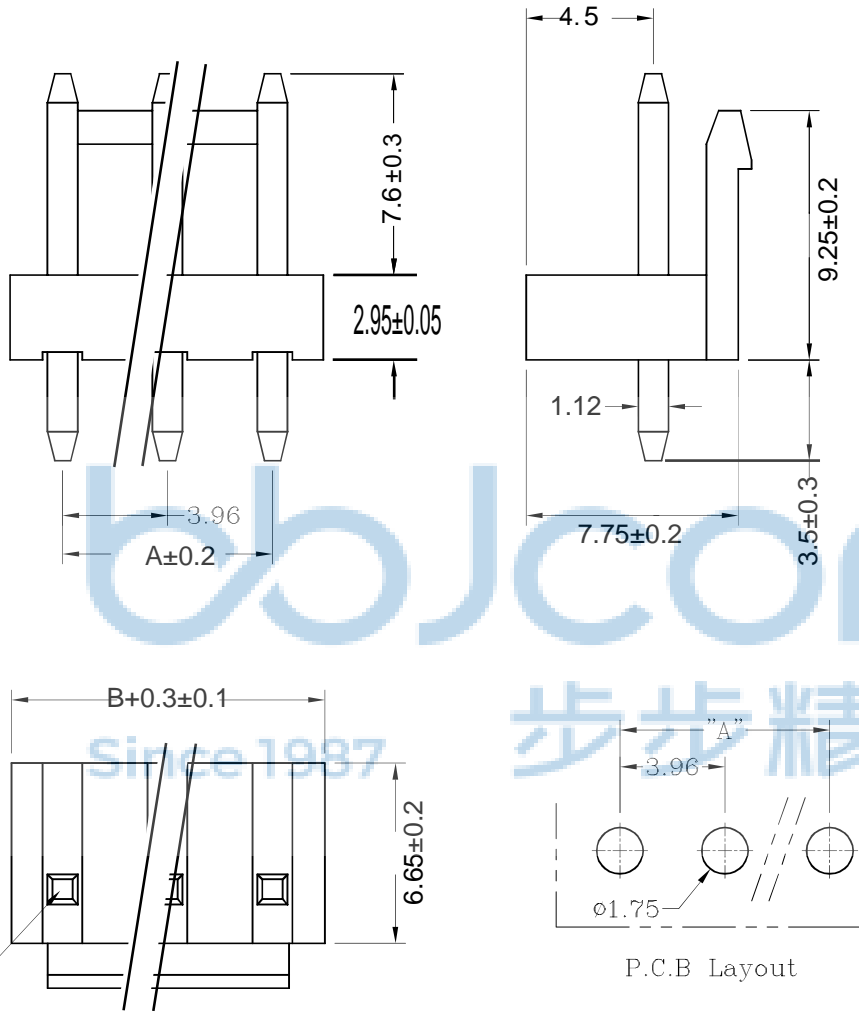

Poles	DIM.A	DIM.B
2	3.96	7.9
3	7.92	11.8
4	11.88	15.8
5	15.84	19.7
6	19.80	23.7
7	23.76	27.7
8	27.72	31.6
9	31.68	35.6
10	35.64	39.5
11	39.60	43.5
12	43.56	47.5
13	47.52	51.4
14	51.48	55.4
15	55.44	59.3

- 技术参数 SPECIFICATIONS
- ◆ 间距: 3.96 Pitch: 3.96
  - ◆ 极数: 2-15 Poles: 2-15
  - ◆ 额定电压: AC, DC, 250V(有效值)  
Rated voltage: AC, DC, 250V(rms)
  - ◆ 额定电流: 3.0A AC, DC  
Rated Current: 3.0A AC, DC
  - ◆ 耐压值: 1000V AC/minute  
Withstand voltage: 1000V AC/min.
  - ◆ 工作温度: -25° C ~ +85° C  
Working Temp : -25° C ~ +85° C
  - ◆ 绝缘电阻: ≥1000 MΩ  
Insulation resistance: ≥1000 MΩ
  - ◆ 接触电阻: ≤20mΩ  
Contact resistance: ≤20mΩ

- 材料 MATERIAL
- ◆ 塑胶: 尼龙 (Nylon), UL94-V0
  - ◆ Pin: 黄铜 (Brass)

- 包装方式 PACKAGE
- ◆ 袋装 Bag Package



THIS DOCUMENT IS THE SOLE PROPERTY OF BBJconn Technology Co.,Ltd. Corporation AND SHOULD NOT BE USED IN WHOLE OR IN PART WITHOUT PRIOR WRITTEN PERMISSION.		深圳市步步精科技有限公司 .X: ±0.38 .X': ±3' .XX: ±0.25 .X': ±2' .XXX: ±0.13 .XX': ±1'		NAME: VH-3A ( 3.96-3P ) 直针 米色 PJ. NO.: WT.03.61-11-1002 SIZE: A4 DRW NO.: FINISH: SEE NOTES MAT'L.: SEE NOTES SCALE: N/A REV.: A0 UNIT: mm PAGE: 1/2	
APPD.	JM_Zheng	CHKD.	LYX	DR.	SGF
PDWG.NO: 0102-1					

REV.	ECN NO	CONTENT	DATE	ENGINEER
A0				

PE袋规格:\*\*\*X\*\*\* (以实际出货为准)

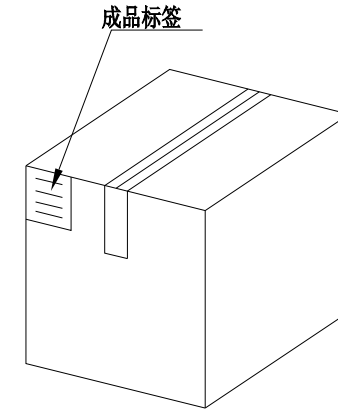
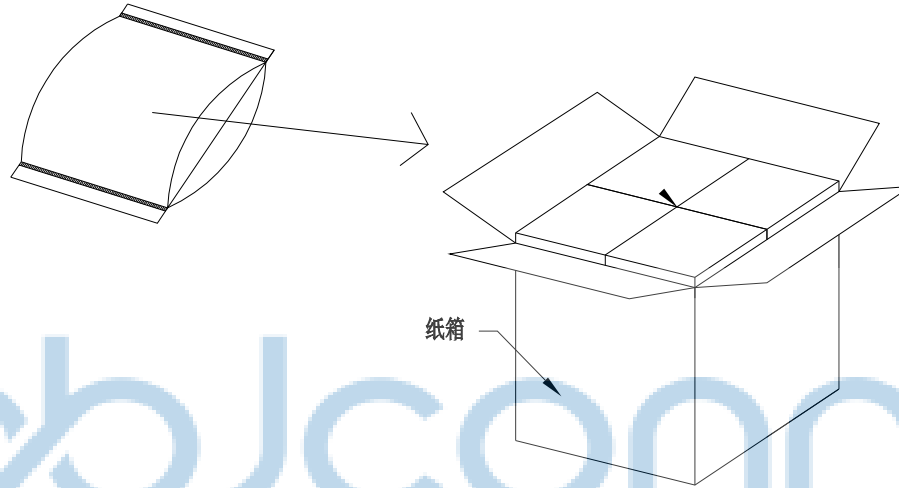

1. 包装要求:

- 1.1 每PE袋包装1000 pcs;
- 1.2 每1袋放一小纸盒;
- 1.3 每20个小纸盒放一个纸箱, 共计20000PCS
- 1.4 纸箱外贴上标签



THIS DOCUMENT IS THE SOLE PROPERTY OF BBJconn Technology Co.,Ltd. Corporation AND SHOULD NOT BE USED IN WHOLE OR IN PART WITHOUT PRIOR WRITTEN PERMISSION.		深圳市步步精科技有限公司 .X: ±0.38    X': ±3' .XX: ±0.25    .X": ±2" .XXX: ±0.13    .XX': ±1'	
APPD.	JM_Zheng	NAME: VH-3A (3.96-3P) 直针 米色	
CHKD.	LYX	PJ. NO.: WT.03.61-11-1002	
DR.	SGF	SIZE: A4   DRW NO.:	
PDWG.NO: 0102-1		FINISH: SEE NOTES   MAT'L.: SEE NOTES	
		SCALE: N/A   REV.: A0   UNIT: mm   PAGE: 2/2	