

REV.	ECN NO.	CONTENT	DATE	ENGINEER
A0				

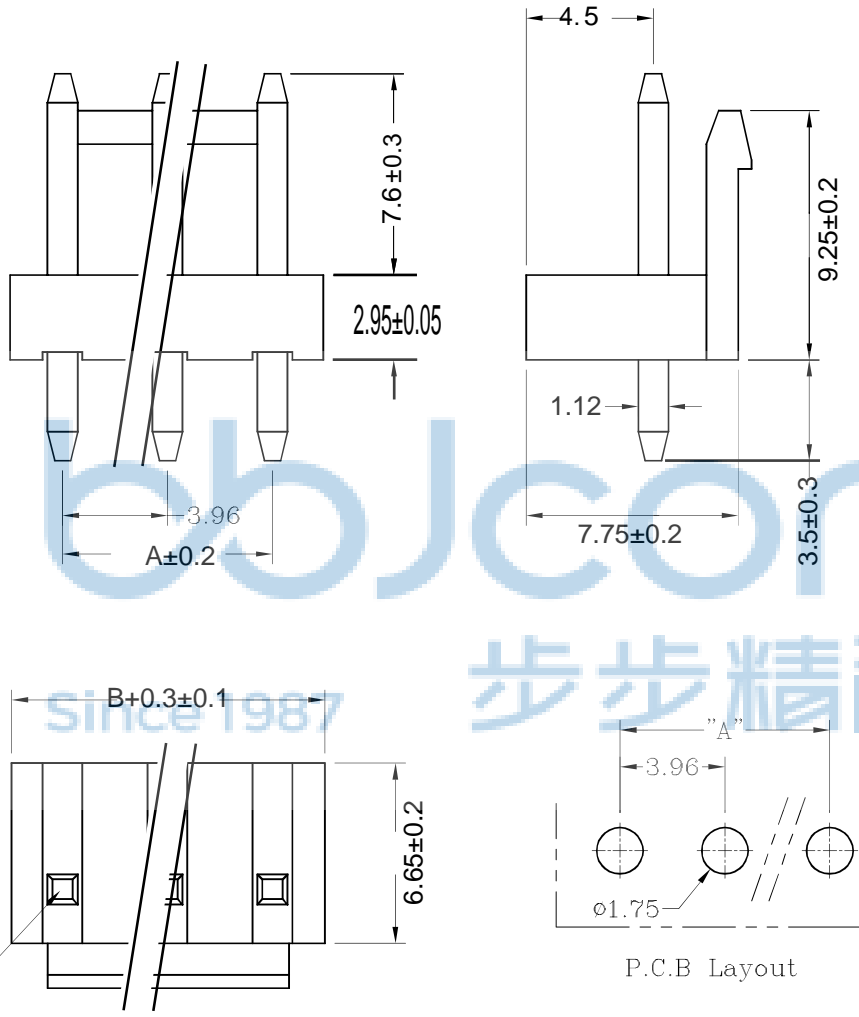

Poles	DIM.A	DIM.B
2	3.96	7.9
3	7.92	11.8
4	11.88	15.8
5	15.84	19.7
6	19.80	23.7
7	23.76	27.7
8	27.72	31.6
9	31.68	35.6
10	35.64	39.5
11	39.60	43.5
12	43.56	47.5
13	47.52	51.4
14	51.48	55.4
15	55.44	59.3

- 技术参数 SPECIFICATIONS
- ◆ 间距: 3.96 Pitch: 3.96
  - ◆ 极数: 2-15 Poles: 2-15
  - ◆ 额定电压: AC, DC, 250V(有效值)  
Rated voltage: AC, DC, 250V(rms)
  - ◆ 额定电流: 3.0A AC, DC  
Rated Current: 3.0A AC, DC
  - ◆ 耐压值: 1000V AC/minute  
Withstand voltage: 1000V AC/min.
  - ◆ 工作温度: -25° C ~ +85° C  
Working Temp : -25° C ~ +85° C
  - ◆ 绝缘电阻: ≥1000 MΩ  
Insulation resistance: ≥1000 MΩ
  - ◆ 接触电阻: ≤20mΩ  
Contact resistance: ≤20mΩ

- 材料 MATERIAL
- ◆ 塑胶: 尼龙 (Nylon) , UL94-V0
  - ◆ Pin: 黄铜 (Brass)
- 包装方式 PACKAGE
- ◆ 袋装 Bag Package

PIN 1

P.C.B Layout



THIS DOCUMENT IS THE SOLE PROPERTY OF BBJconn Technology Co.,Ltd. Corporation AND SHOULD NOT BE USED IN WHOLE OR IN PART WITHOUT PRIOR WRITTEN PERMISSION.

PDWG.NO: 0102-1

APPD. JM\_Zheng

CHKD. LYX

DR. SGF

深圳市步步精科技有限公司

NAME: VH-2A (3.96-2P) 直针 白色

PJ. NO.: WT.03.11-11-1001

SIZE: A4 DRW NO.:

FINISH: SEE NOTES MAT'L.: SEE NOTES

SCALE: N/A REV.: A0 UNIT: mm PAGE: 1/2

REV.	ECN NO	CONTENT	DATE	ENGINEER
A0				

PE袋规格:\*\*\*X\*\*\* (以实际出货为准)

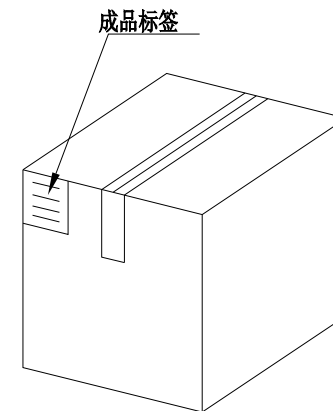
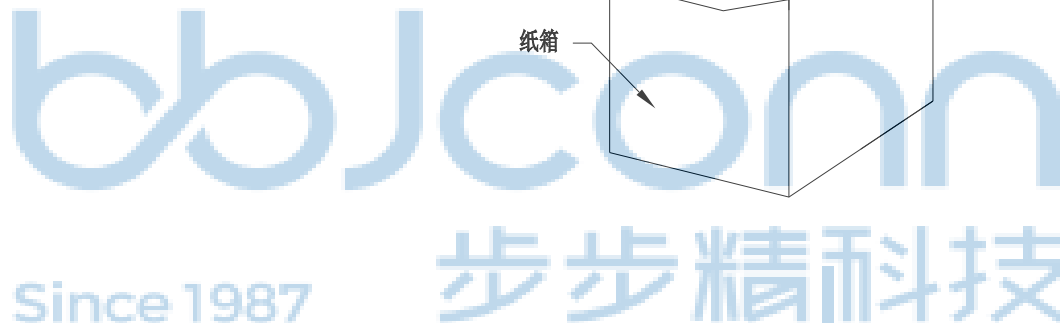
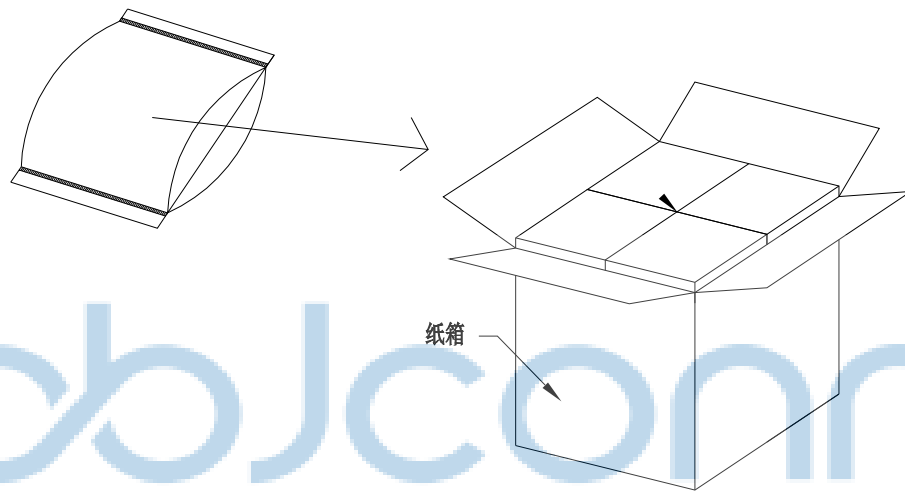

1. 包装要求:

- 1.1 每PE袋包装 1000 pcs;
- 1.2 每1袋放一小纸盒;
- 1.3 每20个小纸盒放一个纸箱, 共计20000PCS
- 1.4 纸箱外贴上标签



THIS DOCUMENT IS THE SOLE PROPERTY OF BBJconn Technology Co.,Ltd. Corporation AND SHOULD NOT BE USED IN WHOLE OR IN PART WITHOUT PRIOR WRITTEN PERMISSION.		深圳市步步精科技有限公司	
PDWG.NO: 0102-1		APPD. JM_Zheng CHKD. LYX DR. SGF	NAME: VH-2A (3.96-2P) 直针 白色 PJ. NO.: WT.03.11-11-1001 SIZE: A4 DRW NO.: FINISH: SEE NOTES MAT'L.: SEE NOTES SCALE: N/A REV.: A0 UNIT: mm PAGE: 2/2